

# Installer's Guide

## 17 Series System (R-410A) Mini-Split, Inverter System

### Single Zone

ALL phases of this installation must comply with **NATIONAL, STATE AND LOCAL CODES**.

**IMPORTANT** — This Document is customer property and is to remain with this unit. Please return to service information pack upon completion of work.

These instructions do not cover all variations in systems or provide for every possible contingency to be met in connection with the installation. Should further information be desired or should particular problems arise which are not covered sufficiently for the purchaser's purposes, the matter should be referred to your installing dealer or local distributor.

Single Split	Indoor Unit	Outdoor Unit
Heat Pump	M4MHW17-A	M4THS17-A
Cooling Only	M4MCW17-A	M4TCS17-A

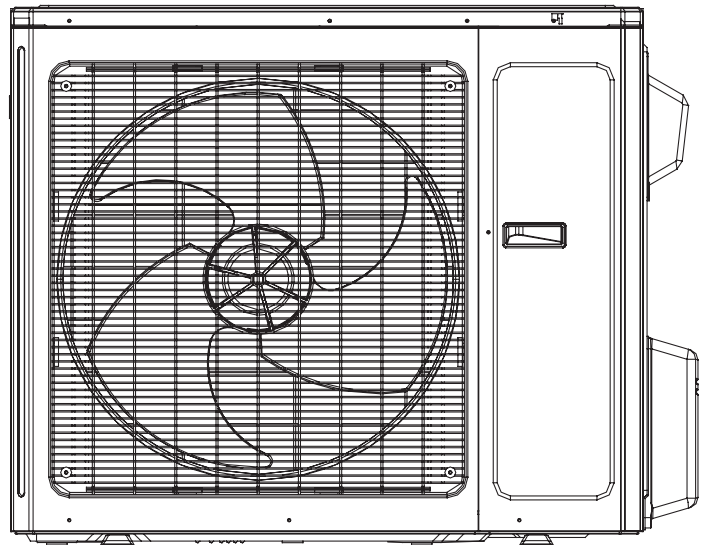
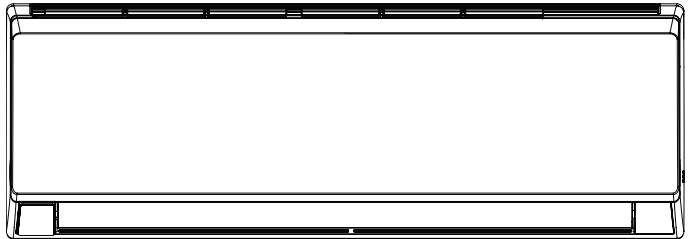

## Warnings and Cautions

Warnings are provided to alert others of the potential hazards that could result in severe personal injury or death, while cautions are designed to alert others of the conditions that could result in minor or moderate injury.

Your personal safety and the proper operation of this machine depend upon the strict observance of these precautions.

**Attention:** Warnings and Cautions appear at appropriate sections throughout this literature. Read these carefully.

**⚠ WARNING:** Indicates a potentially hazardous situation which, if not avoided, could result in death or serious injury.

**⚠ CAUTION:** Indicates a potentially hazardous situation which, if not avoided, could result in minor or moderate injury. It may also be used to alert against unsafe practices.

**NOTICE:** Indicates a situation that could result in equipment or property damage.

### **⚠ WARNING**

**This equipment is to be serviced by professionally trained personnel ONLY. Under NO circumstances should an unqualified person service it. This equipment contains refrigerant under PRESSURE and operates at HIGH VOLTAGE. Improperly installed, adjusted or altered equipment by an unqualified person poses safety hazards including FIRE, ELECTROCUTION, or EXPLOSION, which could result in death or serious injury.**

### **⚠ WARNING**

**Electrocution and Fire Hazards with Improperly Installed and Grounded Field Wiring!**

**Improperly installed and grounded field wiring poses FIRE and ELECTROCUTION hazards. To avoid these hazards, you MUST follow requirements for field wiring installation and grounding as described in the National Electrical Codes (NEC) and your State and/or local electrical codes. All field wiring MUST be performed by qualified personnel. Failure to follow these requirements could result in death or serious injury.**

# Warnings and Cautions

## WARNING

### **R410-A Refrigerant under Higher Pressure than R-22!**

The units described in this manual use R410-A refrigerant which operates at 50 to 70% higher pressures than R-22. Use only R-410A approved service equipment. Refrigerant cylinders are painted with "pink" color to indicate the type of refrigerant and may contain a "dip" tube to allow for charging of liquid refrigerant into the system. For specific handling concerns with R-410A, please contact your local sales office.

Failure to use R-410A approved service equipment could result in standard equipment exploding under R-410A higher pressure which could result in death or serious injury.

### **NOTICE**

Use appropriate oil with R410A systems. Oil type is found at the bottom of Connection Pipe Requirements table (included in the outdoor unit installation manual). R-410A systems utilize POE (Polyolester) or PVE(Polyvinyl Ether) oil. Both oil types absorb moisture readily, yet, lubrication properties vary. Do not leave the sealed system open to atmosphere except during service for a short period of time. If the sealed system is left open longer than four hours, the compressor oil must be changed. These systems utilize strainers placed before and after the expansion device in the outdoor unit, if debris or moisture is suspected, these strainers must be changed. Do not break a vacuum with air. Do not leak check the sealed system with compressed air. Unless instructed by factory service representative, external refrigeration driers are prohibited.

### **USE ONLY THE FACTORY RECOMMENDED OIL TYPE!**

### **Important!**

### **Environmental Concerns**

Scientific research has shown that certain man-made chemicals can affect the earth's naturally occurring stratospheric ozone layer when released to the atmosphere. In particular, several of the identified chemicals that may affect the ozone layer are refrigerants that contain chlorofluorocarbons (CFC's) and those containing hydro-chlorofluorocarbons (HCFC's). Not all refrigerants containing these compounds have the same potential impact to the environment. The Company advocates the responsible handling of all refrigerants, including industry replacements for CFC's such as HCFC's and HFC's.

### **Responsible Refrigerant Practices**



The manufacturer believes that responsible refrigerant practices are important to the environment, our customers, and the air conditioning industry. All technicians who handle refrigerants must be certified. The Federal Clean Air Act (Section 608) sets forth the requirements for handling, reclaiming, recovering and recycling of certain refrigerants and the equipment that is used in these service procedures. In addition, some states or municipalities may have additional requirements that must also be adhered to for responsible management of refrigerants. Know the applicable laws and follow them.

**Table of Contents**

Safety Precautions .....	5
Pre-Installation Checklist .....	6
Items Shipped With the System .....	7
Necessary Tools .....	7
Typical Installation Setup .....	8
Names and Functions of Each Part.....	8
Clearance Requirements.....	9
Connection Pipe Requirements.....	10
Refrigerant Piping Precautions.....	11
Nitrogen Purging While Brazing.....	11
Installation Location.....	12
Installing the Indoor Unit.....	13
Mounting Location .....	13
Drilling the Piping Hole .....	14
Refrigerant Piping at the Indoor Unit .....	15
Installing the Condensate Pipe.....	17
Wiring at the Indoor Unit.....	17
Binding the Pipes and Cables .....	19
Hanging the Indoor Unit.....	19
Installing the Outdoor Unit.....	20
Condensate Management of the Outdoor Unit.....	20
Installing the Refrigerant Piping.....	21
Flaring Process and Bending Pipes .....	21
Refrigerant Piping at the Outdoor Unit .....	22
Insulating the Refrigerant Piping and Connections .....	22
Piping Requirements .....	23
Vacuum and Refrigerant Leakage Detection.....	24
Wiring Precautions .....	25
Outdoor Wiring Connections .....	25
Stranded Wiring Connections.....	26
Electrical Connections.....	27
Power Supply Wiring.....	28
Cable Specifications and Grounding Requirements.....	28
Installation of Controllers.....	28
Post Installation Checklist.....	29
Test Operation .....	29
Refrigerant System Diagrams .....	30
Wiring Diagrams .....	31
Unit Dimensions .....	34
Common Error Codes.....	37
Troubleshooting .....	39
Auxillary Operation .....	40
Indoor Unit Maintenance .....	40
General Maintenance .....	41

## Safety Precautions

Your personal safety and the proper operation of this equipment depend upon the strict observance of these precautions.

 <b>WARNING</b>	This mark indicates a potentially hazardous situation which, if not avoided, could result in death or serious injury.
 <b>CAUTION</b>	This mark indicates a potentially hazardous situation which, if not avoided, could result in minor or moderate injury. It may also be used to alert against unsafe practices.
<b>NOTICE</b>	This mark indicates a situation which could result in equipment and/or property damage.

 <b>WARNING</b>	
1.	Installation should performed by a qualified HVAC professional. Industry Standard Personal Protective Equipment (PPE) and gear for height related safety should be worn during installation. Improper personal safety precautions and installation may cause death or serious injury.
2.	Install the air conditioner according to the instructions given in this manual. Incomplete installation work may cause water leakage, electrical shock or fire.
3.	Use the supplied or specified installation parts. Use of other parts may cause the unit to come loose, resulting in water leakage, electrical shock or fire.
4.	Install the unit in a location that can support the weight of the unit. An inadequate support structure or incomplete installation may cause injury or property damage in the event the unit falls off of the installation location. Refer to the installation specifications for additional requirements.
5.	Electrical work should be carried out in accordance with the installation manual and local, state and National Electric Code (NEC). Insufficient capacity or incomplete electrical work may cause electrical shock or fire.
6.	Use a dedicated power circuit. Never use a power supply shared by another appliance.
7.	For wiring, use a cable that is long enough to cover the entire distance without splicing. Do not use an extension cord. Do not put other loads on the power supply; use a dedicated power circuit. Failure to do so may cause abnormal heat, electric shock or fire.
8.	Use the specified types of wires for electrical connections between the indoor and outdoor units. Firmly clamp the interconnecting wires so their terminals receive no external stresses. Incomplete connections or clamping may cause terminal overheating or fire.
9.	After joining the interconnecting and supply wiring, shape the cables so that they do not put undue force on the electrical covers or panels. Install covers over the wires. Incomplete cover installation may cause terminal overheating, electrical shock, or fire.
10.	If any refrigerant leaks out during the installation, ventilate the room. The refrigerant produces a toxic gas if exposed to flames.
11.	When installing or relocating the system, keep the refrigerant circuit free from substances other than the specified refrigerant (R410-A), such as air. The presence of air or other foreign substances in the refrigerant circuit can cause an abnormal pressure rise or rupture, which could result in injury and damage.

## Installer's Guide

12. If a system pump-down is performed, turn off the associated equipment and close service valves prior to removing the refrigerant piping. Failure to do so will introduce non-condensables in the system, causing abnormal pressure in the refrigeration cycle which could lead to injury and damage.
13. Before system start-up, attach the refrigerant piping securely. Failure to do so will introduce non-condensables into the system when the compressor is running, causing abnormal pressure in the refrigeration cycle which could lead to injury and damage.
14. Establish a complete ground. Do not ground the unit to a utility pipe, arrester, or telephone ground. An incomplete ground may cause electrical shock, or fire. A high surge current from lightning or other sources may cause damage to the air conditioner.
15. If the power supply cable is damaged, it must be replaced by the manufacturer, its service agent or another qualified professional in order to avoid electrical risk during and after replacement.



1. Do not install the unit in a place where there is danger of exposure to flammable gas leakage. If gas leaks and builds up around the unit, it may result in fire.
2. After system installation is completed, make sure no refrigerant leakage is present.
3. This appliance is not intended for use by persons with a lack of experience and knowledge, unless they have been given adequate supervision or instruction concerning use of the appliance by a person responsible for their safety.
4. Children should be supervised to ensure that they do not play with the appliance.

### NOTICE

1. Establish drain piping according to the instructions in this manual. Inadequate piping may cause flooding.
2. Tighten the flare nut according to the specified method. If the flare nut is tightened too hard, the flare nut may crack and cause refrigerant leakage.

## Pre-Installation Checklist

1. Unpack and inspect each unit.
2. Check for any damage to the unit.
3. Check the model numbers to ensure a proper match.
4. Check the unit nameplate to ensure the proper electrical requirements will be met.
5. Check the installation locations to ensure the weight of the units can be supported.
6. Check the refrigerant pipe sizes and ensure they have been or will be installed according to the requirements in this manual.
7. Check the outdoor unit nameplate for electrical power supply and wiring requirements to ensure the proper wiring has been installed prior to connection.
8. Check the indoor unit for coil leakage. The pressure relief valve on the gas pipe should release pressurized nitrogen which ensures the unit has not leaked during shipping.

## **Items Shipped with the 17 Series Mini-Split System**

After unpacking the unit(s), please refrain from disposing of the packaging materials until items listed below are located. If any of these are missing, please contact the point of sale to obtain these items.

### **Indoor Unit**

1. Wireless handheld remote control
2. Refrigeration pipe insulation (short piece)
3. Mounting Plate
4. Installation instructions (may be included in outdoor unit)
5. Batteries for the remote control\*
6. Flare nuts for connecting refrigerant pipes\*
7. Mounting fasteners\*

### **Outdoor Unit**

1. Installation Manual
2. Warranty Letter
3. Drain pipe connector

\*typically packaged in cellophane bubble

### **Necessary tools**

1. Drill
2. Hole Saw
3. Phillips(TM) screwdriver
5. Vacuum pump capable of pulling to 350 microns
6. Manifold gauge set designed for this type of equipment
7. Manifold gauge hoses with 5/16" connections or 1/4" to 5/16" adapters.
8. Tubing benders
9. R-410A Flaring tool
10. Adjustable wrench
11. Nitrogen regulator
12. Nitrogen flow meter
13. Tube cutter

Typical Installation Setup

Names and functions of each part

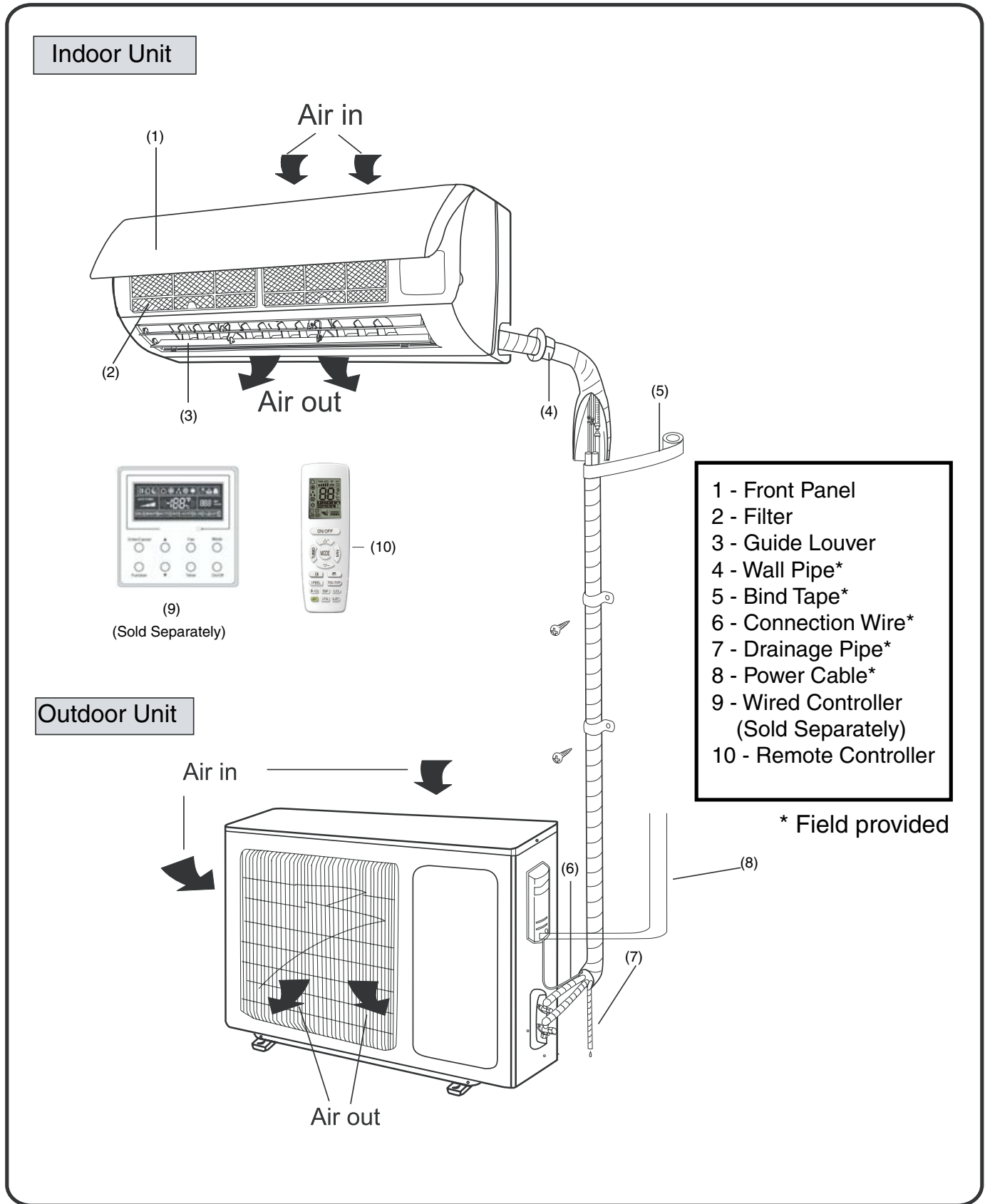



## Clearance Requirements

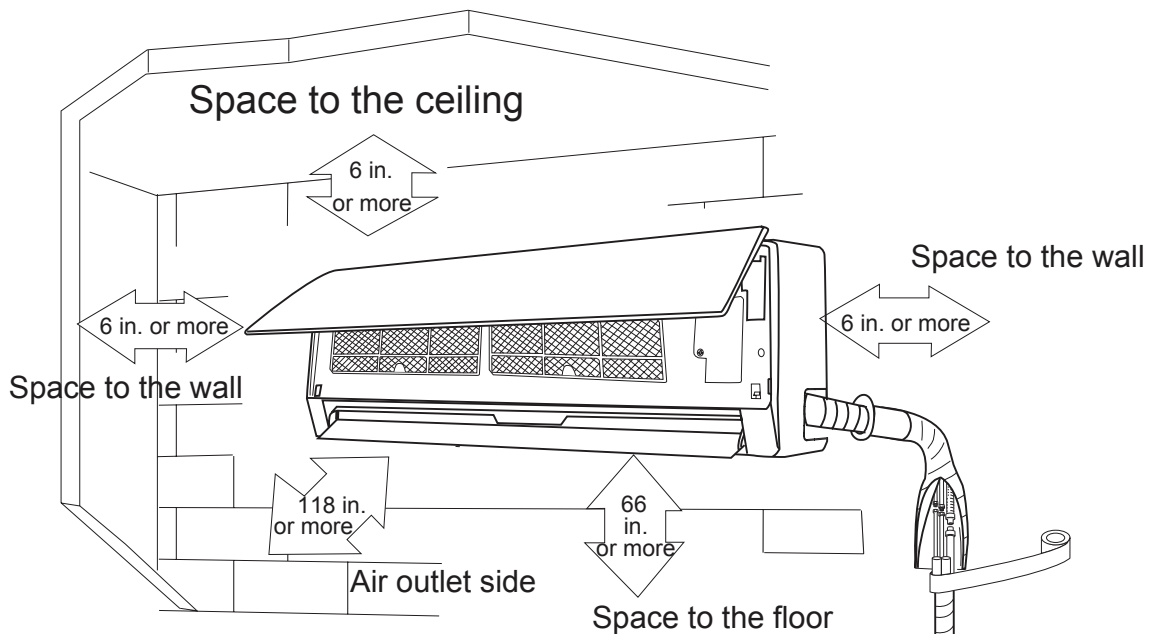

The dimensions of the space necessary for correct installation of the appliance including the minimum permissible distances to adjacent structures

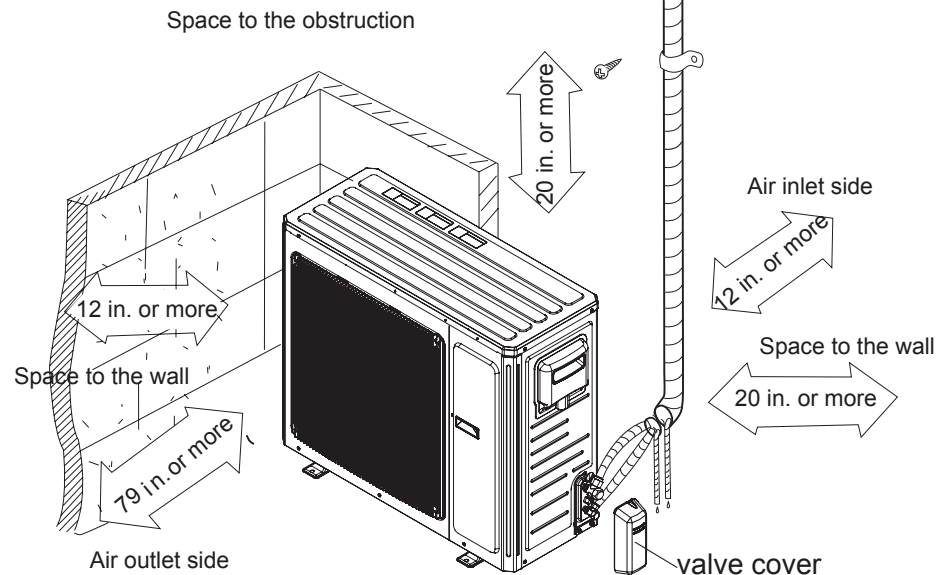

**NOTE:**

The maximum recommended height from the floor to the bottom of the indoor unit is 11.5 ft. (3.5 m).

## Connection Pipe Requirements

### NOTICE

The maximum length of the connection pipe is listed in the table below. Do not place the units such that the distance between them exceeds the maximum length of the connection pipe.

Heat Pump		M4THS1709A	M4THS1712A	M4THS1718A	M4THS1724A
		M4MHW1709A	M4MHW1712A	M4MHW1718A	M4MHW1724A
Refrigerant Charge (oz.)		24	28.2	42.3	52.9
Standard Length m (ft)		7.6 (25)			
Additional Refrigerant Charge (oz/ft) For Piping Beyond Standard Length		0.2			0.5
Outer Diameter	Liquid Pipe mm (in)	Φ 6.35 (1/4")			
	Gas Pipe mm (in)	Φ 9.52 (3/8")		Φ 12.7 (1/2")	15.875 (5/8")
Max Distance	Height m (ft)	10 (32.8)			
	Length m (ft)	15 (49.2)	20 (65.6)	25 (82)	
Minimum Piping Length m (ft)		3 (10)			
Compressor Oil Used		FW68DA		RB68EP	FW68DA

Cooling Only		M4TCS1709A	M4TCS1712A	M4TCS1718A	M4TCS1724A
		M4MCW1709A	M4MCW1712A	M4MCW1718A	M4MCW1724A
Refrigerant Charge (oz.)		19.1	25	37	52.9
Standard Length m (ft)		7.6 (25)			
Additional Refrigerant Charge (oz/ft) For Piping Beyond Standard Length		0.2			
Outer Diameter	Liquid Pipe mm (in)	Φ 6.35 (1/4")			
	Gas Pipe mm (in)	Φ 9.52 (3/8")		Φ 12.7 (1/2")	15.875 (5/8")
Max Distance	Height m (ft)	10 (32.8)			
	Length m (ft)	15 (49.2)	20 (65.6)	25 (82)	
Minimum Piping Length m (ft)		3 (10)			
Compressor Oil Used		FW68DA			

### NOTES:

1. The connection pipe should be insulated with proper water-proof insulating material
2. Wall thickness of pipe 0.5-1.0 mm (0.02-0.04 in): bearing pressure 435 PSI (3.0 MPa)
3. Shorter connecting pipe lengths result in greater thermal efficiency, so it is preferable to reduce connecting pipe lengths where possible.
4. See the oil trap instructions on page 21 for specific requirements when there is height difference between the indoor and outdoor unit greater than 20 feet.

### Operating Ranges

Cooling Operating Range	Outdoor Temperature 0 - 115°F (-18 - 46.1°C)
Heating Operating Range	Outdoor Temperature -4 - 75°F (-20 - 24°C)
Indoor Operating Range	Indoor Temperature 61 - 86°F (16 - 30°C)

## Refrigerant Piping Precautions



### Hazard of Explosion and Deadly Gases!

Failure to follow all proper safe refrigerant handling practices could result in death or serious injury. Never solder, braze or weld on refrigerant pipes or any unit components that are above atmospheric pressure or where refrigerant may be present. Always remove refrigerant by following the guidelines established by the EPA Federal Clean Air Act or other state or local codes as appropriate. After refrigerant removal, use dry nitrogen to bring system back to atmospheric pressure before opening system for repairs. Mixtures of refrigerants and air under pressure may become combustible in the presence of an ignition source leading to an explosion. Excessive heat from soldering, brazing or welding with refrigerant vapors present can form highly toxic gases and extremely corrosive acids.

### NOTICE

#### System Component Damage!

Do not remove the seal caps from the refrigerant connections and piping until prepared to braze refrigerant pipes to the connections. Excessive exposure to atmosphere (greater than 5 minutes) may allow moisture or other particulates to contaminate the system, damaging valve seals and causing ice formation in the system components during operation.

## Nitrogen Purging While Brazing

### NOTICE

#### Avoid Unit Damage!

Never braze pipe connections without performing nitrogen purging. Failure to perform this procedure will damage the unit, resulting in capacity loss and reduced long-term reliability.

While brazing refrigerant pipes, continuously purge them with nitrogen gas. Use a pressure regulator to maintain a flow rate of 1.76 ft<sup>3</sup>/h (0.05 m<sup>3</sup>/h) or more.

Nitrogen purging while brazing refrigerant pipes

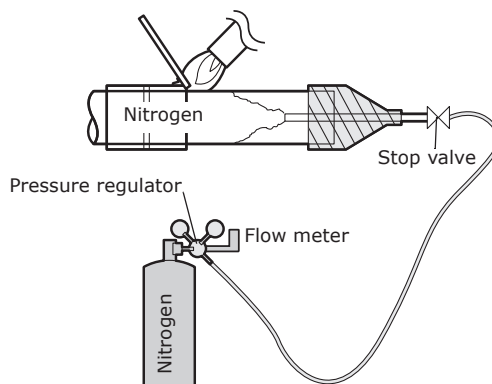

## Installation Location

### Indoor Unit



#### **Adequate Support Required!**

The wall structure must be adequate to support the weight of the unit. Failure to ensure adequate structural support could result in death, serious injury, and equipment or property damage.

1. Avoid locating the indoor unit where the return and/or supply air may be obstructed.
2. Select a location where equipment condensate can be appropriately drained.
3. Keep the indoor unit away from heat sources, vapor, and flammable gas.
4. Select a location that meets or exceeds the clearance specifications in this manual.
5. Allow space for routine maintenance, such as changing filters or servicing the equipment.
6. Install in a location sufficiently away from other electronic appliances that could cause interference, such as television, audio devices, etc.

### Selecting the Installation Location

#### Outdoor Unit



1. Install the unit on a level surface or on supports that are level.
2. If the location is subject to strong winds, the additional force must be accounted for and the unit must be fixed securely to the base. Refer to local codes for additional requirements.

1. Select a location where equipment noise and air discharge annoyance is minimized.
2. Select a location where there is sufficient ventilation.
3. Make sure the air inlet and outlet are not blocked by any obstacles
4. Select a location capable of supporting four times the weight of the unit, that will not increase vibration, and where installation work can be carried out safely.
5. Select a location away from flammable gas or gas leaks.
6. Ensure installation of the outdoor unit conforms to the clearance specifications in this manual.
7. Locate the outdoor unit away from any bedroom windows.

#### **NOTICE**

**Installing the unit in one of the following locations could result in unit malfunction:**

1. Places where oil (machine oil) is used.
2. Seaside places with high levels of salt in the air.
3. Places with high levels of sulphur gas such as areas with hot springs.
4. Places where high-frequency waves are generated by radio equipment, welders and medical equipment.
5. Other unusual places where unit operation may be altered.
6. Places where minimum clearances cannot be met.

## Installing the Indoor Unit



### **Hazardous Service Procedures!**

The maintenance and troubleshooting procedures recommended in this section of the manual could result in exposure to electrical, mechanical or other potential safety hazards. Always refer to the safety warnings provided throughout this manual concerning these procedures. Disconnect all electrical power including remote disconnect and discharge all energy storing devices such as capacitors before servicing. Follow proper lockout/tag out procedures to ensure the power can not be inadvertently energized. When necessary to work with live electrical components, have a qualified licensed electrician or other individual who has been trained in handling live electrical components perform these tasks. Failure to follow all of the recommended safety warnings provided, could result in death or serious injury.

### **Mounting Location**

1. Confirm the mounting location with the customer. Keep in mind the guidelines for a safe installation location on page 8-9.
2. Place the wall-mounting frame on the wall and check that it is level. Mark the screw holes to be drilled, ensuring they are in a place with adequate support.
  - a. It is equally important to assure the mounting surface (i.e. wall) is flat. Use a straight edge to assure the section of the mounting surface, in which the unit will be secured, is neither concave or convex.
  - b. For corrugated walls, indoor unit installation is recommended on a solid backing affixed to the wall.
3. Drill the holes on the wall according to the selected marks. If the mounting plate cannot be directly affixed to wall studs or other solid backing, wall anchors shall be used to secure mounting plate.
4. Attach the wall-mounting frame with the supplied tapping screws and check to make sure it is firmly attached. If any of the screws or anchors are loose, select another point on the frame to re-drill and attach securely.
5. Be sure that the wall-mounting frame has been secured firmly enough to withstand the weight of the unit. The weight should be evenly distributed to the fasteners.
6. Prior to leaving the job site, seal any and all openings in the wall caused by the installation process.

09K:

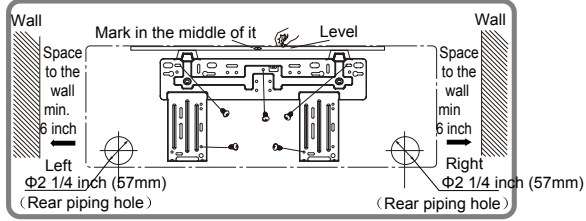

12K:

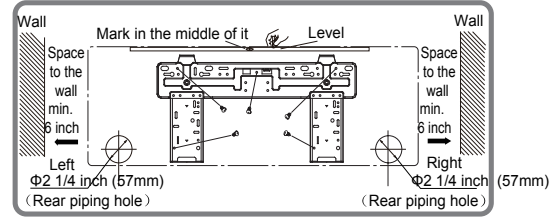

18K:

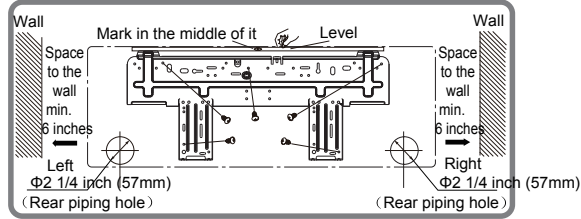

24K:

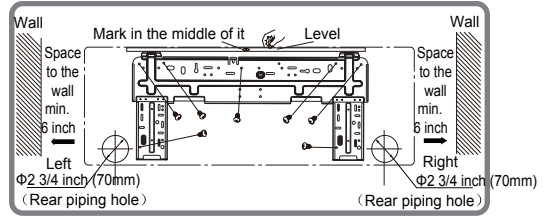

## Drilling the Piping Hole

The piping can be connected in the direction of right, rear right, left or rear left.

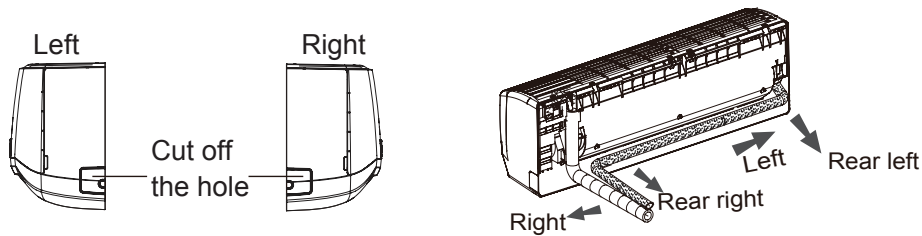

1. When the position of the drain piping has been selected, cut out the corresponding knock-out from the unit housing.
2. Select the position of the piping hole to be drilled according to the direction of the drain pipe position selected for the application. The position of the piping hole should be slightly lower than the wall mounted frame.
3. Drill a hole with the diameter of 2 3/16 inch or 2 3/4 inch (24K unit) for the selected outlet pipe position. In order to drain smoothly, slant the piping hole on the wall slightly downward to the outdoor side with a gradient of 5-10°. (As shown below)
4. Insert a sleeve into the hole to prevent the connection piping and wiring from being damaged when passing through the hole.

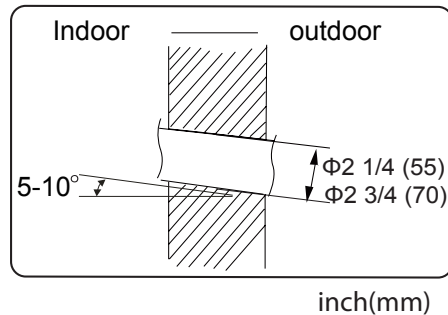

**NOTICE**

If a wall sleeve is not used, unnecessary damage to the piping and wiring could occur. This typically results in current loss, improper grounding, and pipe leaks, Ensure no undue forces are on the piping and wiring through wall(s) and adequate draining still occurs.

**Refrigerant Piping at the Indoor Unit**

Note: Until the outdoor unit is set and ready to connect refrigeration pipes, do not remove the caps from the indoor unit.

**NOTICE**

1. Connect each pipe to its port on the indoor unit correctly. If the centering is improper, the flare nut cannot be tightened smoothly. If the flare nut is forced to turn, the threads will be damaged. Refer to the flaring process guidelines in this manual for additional information.
2. Do not remove the tube caps nut until the connection pipe is made ready to prevent dust and impurities from entering the system.

1. When connecting refrigerant pipe to the unit or removing it from the unit, please use both a back-up wrench and the torque wrench. See illustration on page 16.
2. When connecting, place the equipment specified oil type on the backside of the copper tube flare prior to tightening. Do not place oil on the flare face, as this will promote system contamination, tighten it by hand and then tighten it with the spanner or adjustable wrench.
3. Refer to the torque reference table below before tightening to determine the appropriate torque (over-tightening will damage the nut and lead to leakage).
4. Use dry Nitrogen to pressurize the piping circuit with 150 PSIG and allow it to hold while performing other installation processes. It is recommended to apply a soap bubble solution and observe the connection.
5. Evacuate each individual refrigeration circuit to 350 microns or below, and close off the valve to the vacuum pump. If the pressure rises above 500 microns within one minute, but not above 1500 microns within 5 minutes, moisture is present. If the pressure continues to rise above 1500 microns, a leak exists in the circuit being tested.
  - a) If moisture is present, use triple evacuation process to eliminate the moisture.
  - b) If a leak is present, leak check all joints and piping.

Evacuation is not completed until the micron gauge does not rise above 500 microns within one minute after achieving 350 micron pressure vacuum.

6. After evacuation is complete, additional charge can be added.
  - a) If no additional charge is required, break the vacuum with refrigerant, then remove the gauge connectors.
  - b) slightly open the liquid valve at the OD unit, allow system to equalize, then fully open the liquid valve and then open the vapor service valve.
7. After leak checking is complete, apply thermal insulation around the flare connections and all exposed refrigeration pipes. Refer to the guidelines for insulating refrigerant piping and connections in this manual for additional information.
  - a) Seal the insulation.
  - b) Inspect the insulation to assure no breakages are present.

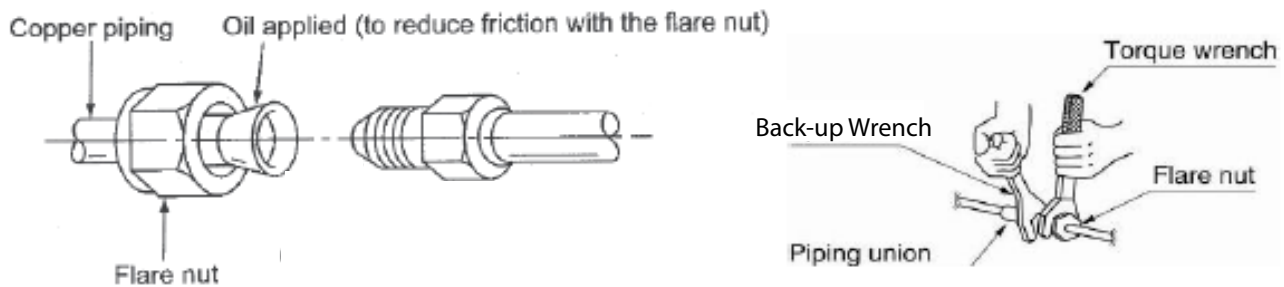
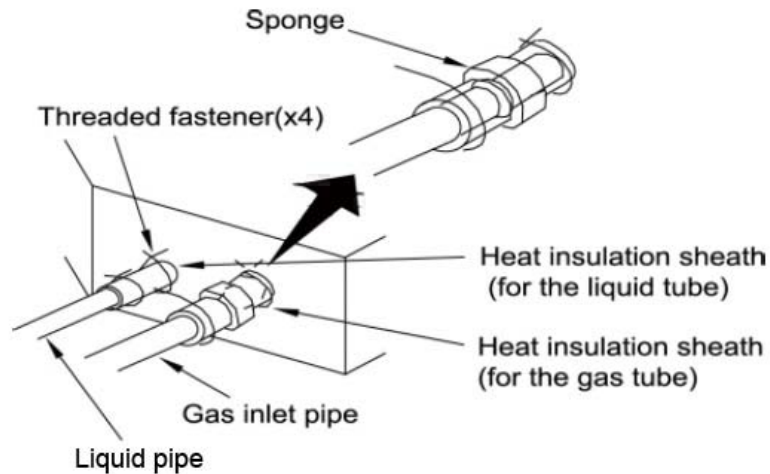

Pipe Diameter in. (mm)	Tightening Torque
1/4 (6.35)	11.25-14.75 ft-lbf / 15 ~ 20 N•m
3/8 (9.52)	22.25-29.50 ft-lbf / 30 ~ 40 N•m
1/2 (12.7)	33.25-40.50 ft-lbf / 45 ~ 55 N•m
5/8 (15.9)	44.25-47.75 ft-lbf / 60 ~ 65 N•m



## Installing the Condensate Pipe

### NOTICE

Do not sharply twist or curve the condensate drain pipe. Ensure pipe ends are not submerged in water. Drain pipe must provide adequate flow and slope downward to the outlet. Failure to do so may result in leakage and overflow of the drain pan.

1. Connect the drain hose to the outlet pipe of the indoor unit (shown in Fig. A below).
  2. Bind the joint with tape (shown in Fig. B below).
  3. Wrap the pipe with insulating tape to prevent condensation (shown in Fig. C below).
- Note: The drain pipe must be routed lower and sloped downward away from the indoor unit.

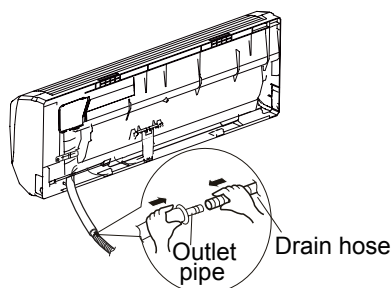

Fig. A

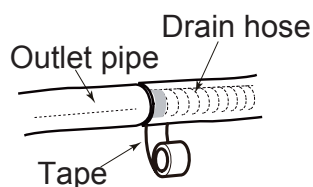

Fig. B

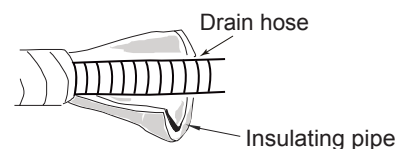

Fig. C

## Wiring at the Indoor Unit

### ⚠ WARNING

Disconnect all electrical power and discharge all energy storing devices such as capacitors to the outdoor unit(s) prior to wiring the indoor unit(s) to avoid risk of death, injury, or damage to equipment.

1. Open the front panel of the indoor unit, remove the screw on the wiring cover and remove the cover (shown in Fig. D below).
2. Thread the power connection wire through the cable-cross hole at the back of the indoor unit and pull it through to the front side (shown in Fig. E below).

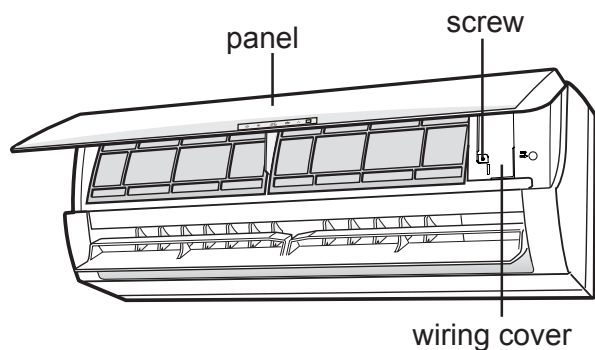

Fig. D

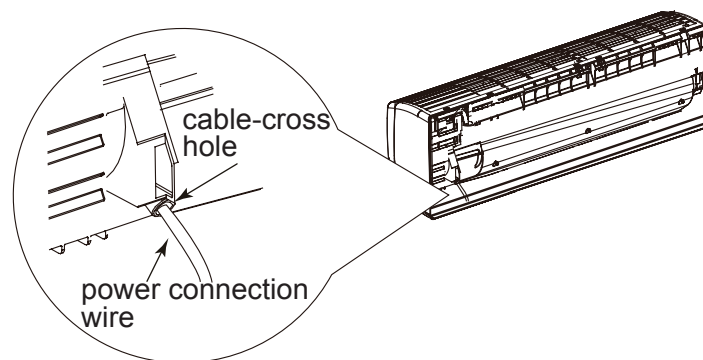
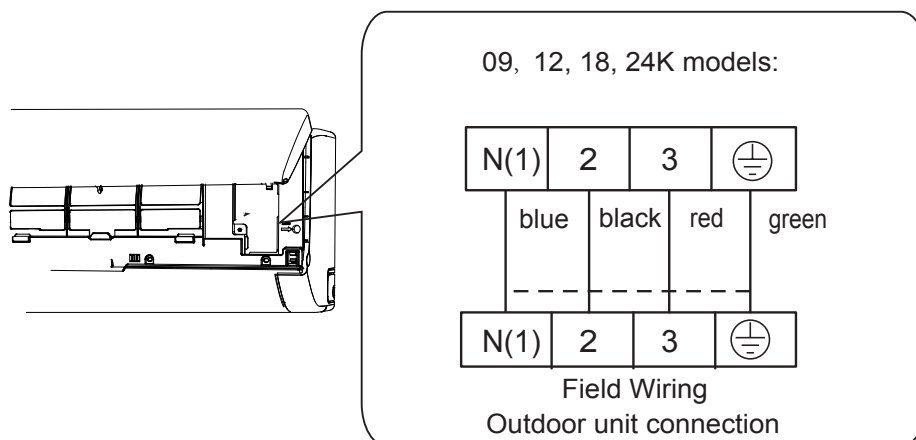

Fig. E

3. Remove the wire clip and connect the power connection wire to the wiring terminal according to the correct color coding. It is recommended to use 4 wire colors (for example: Blue, Black, Red, Green. Connect Blue to 1, Black to 2, Red to 3 and Green to Ground). All wiring shall use ring or spade type crimped or soldered connectors (as shown in the outdoor unit installation section or manual). Ensure electrical connections are tight and strain reliefs are in place. Regardless of wire color used, The wire terminals labeled 1, 2, 3 and ground must be landed on the corresponding terminal in the outdoor unit.
4. Put the wiring cover back on the unit and tighten the fastener.
5. Close the front panel.
6. The primary disconnect for both the indoor and outdoor unit shall be wired to disconnect the branch circuit feeding the outdoor unit. The Indoor unit obtains high voltage and communication from the outdoor unit. If the AHJ (authority having jurisdiction) requires a branch circuit disconnect before the indoor unit, then break all three legs between the outdoor unit and indoor unit using a switch with current ratings suitable for use with these types of systems.
7. The system must be disconnected at the outdoor unit before performing service or maintenance to avoid risk of electric shock or damage to equipment.
8. Terminal 2 carries communication signals and should not be cut or spliced. Do not use splices in any wire between the indoor and outdoor unit.
  - a) If an external drain pump with a float switch is utilized, power the drain pump from terminals 1 and 3; the float switch should be wired to break leg 3.
  - b) Do not break the wire that connects terminal N(1) from the outdoor unit to terminal N(1) on the indoor unit or the wire that connects terminal 2 from the outdoor unit to terminal 2 on the indoor unit with a float switch.
9. The ground wire must connect directly from the outdoor unit to the indoor unit. To avoid communication errors, do not connect the ground wire to the terminal block from any other location.



**NOTE: Field wiring colors indicated in this illustration are intended as an example and may differ based on the electrical contractor choice of wire colors.**

**NOTE: The wiring diagrams in this guide are included as a reference. The manufacturer has a policy of continuous product and product data improvement and reserves the right to change design and specifications without notice. Always check the unit nameplate and wiring diagram for the actual unit requirements.**

## Binding the Pipes and Cables

**Note:** The refrigeration pipes shall be insulated separately to prevent heat transfer between the two pipes.

1. At the beginning of the indoor connections, bind the insulated refrigerant pipes, power cable, and drain hose by evenly wrapping them with an appropriate pipe tape.
2. When the drain hose needs to be separated from the binding towards the discharge point, separate the power cable and drain hose from this binding.
3. Wrap and secure the drain hose connection at its end.
4. Evenly wrap the separately insulated liquid and gas pipes until they are close to the outdoor connection.
5. Near the outdoor unit connection, separately wrap these pipes.

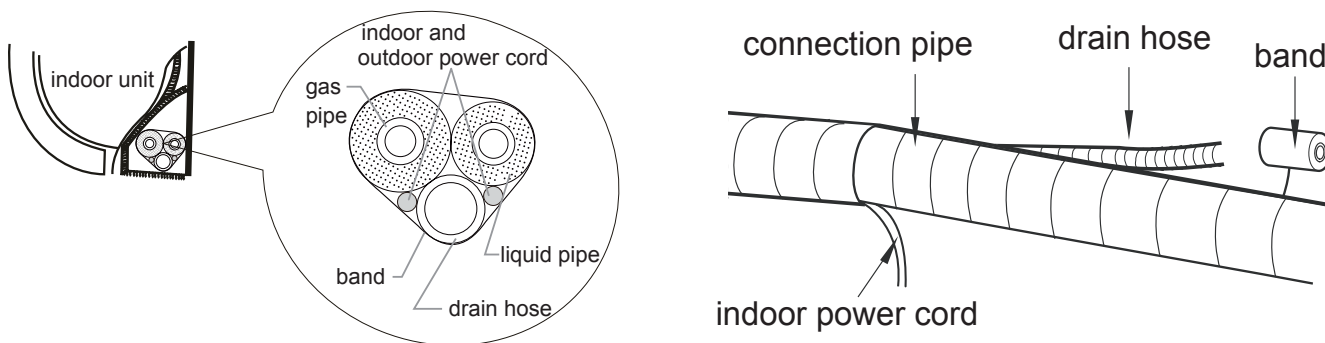

## Hanging the Indoor Unit

**Note:** It is recommended the indoor unit be mounted on a non-porous flat surface. Doing so will reduce unfiltered air from entering the unit as well as reduce sweating behind the unit. Ensure the insulation sections surrounding the refrigeration and condensate pipes are sealed and without cracks or openings.

1. Insert the bound pipes and wires into the wall sleeve and pass through to the outside.
2. Hang the indoor unit on the wall-mounting frame.
3. Seal any and all openings and gaps with sealant.
4. Secure the wall pipe bundle with saddles.
5. Ensure the indoor unit is securely and tightly installed to the wall.
6. Do not bend the drain hose excessively to prevent blockage.

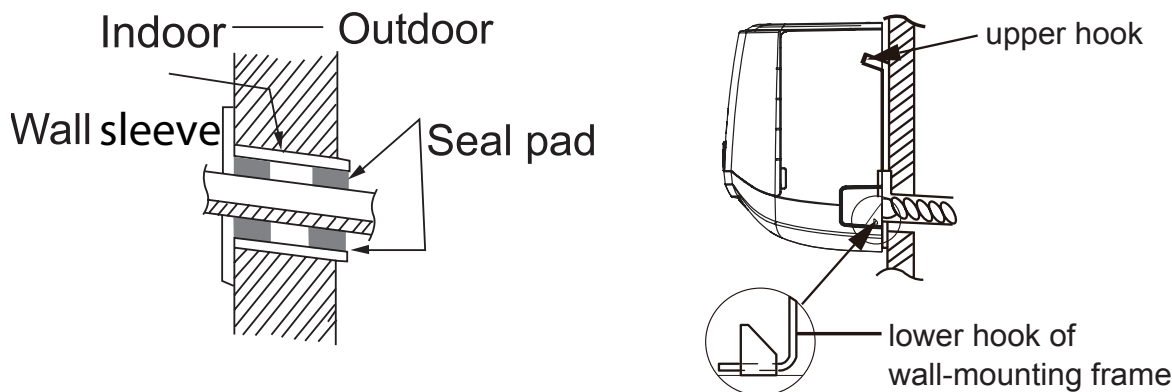

## Installing the Outdoor Unit

**⚠ WARNING**

1. Install the unit on a level surface or on supports that are level.
2. If the location is subject to strong winds, the additional force must be accounted for and the unit must be fixed securely to the base. Refer to local codes for additional requirements.

When the outdoor unit is surrounded by walls or other obstructions, the installation space of the unit should be no less than the clearances indicated below. For efficient operation, leave three of four directions of peripheral constructions open when possible.

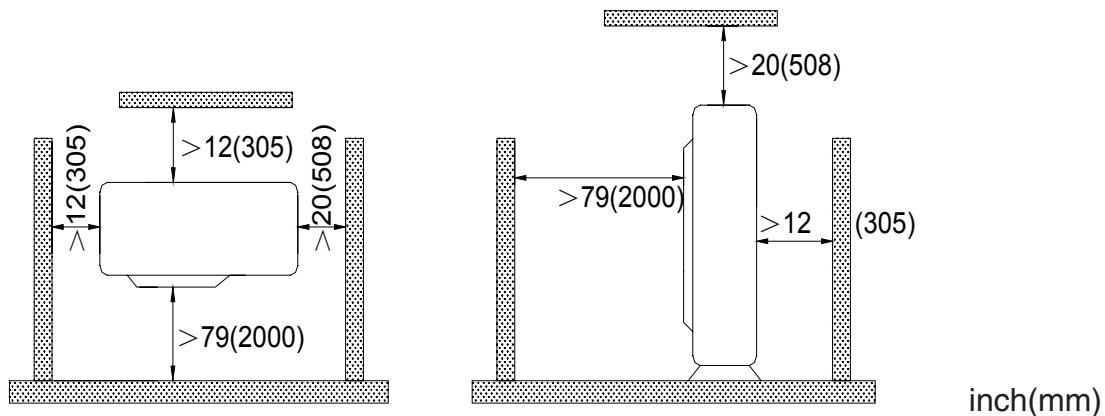

Select the installation location that provides easy access to the indoor unit.

1. Make sure the location can support at least four times the weight of the unit.
2. Secure the outdoor unit on the selected base location with expansion screws.
3. The outdoor unit should be installed at least 1 1/4 inch above the ground or base in order to install a drain pipe and connector (shown below).

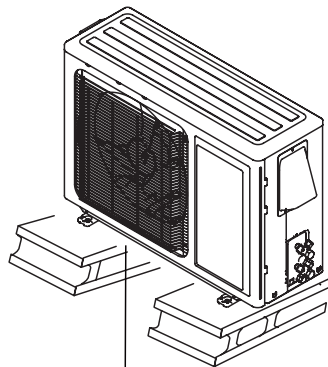

At least 1 1/4 inch (31.8mm) clearance

### Condensate Management of the Outdoor Unit

1. The outdoor unit(s) should be located where condensate poses no hazard or safety risk. Each unit is supplied with a drain pipe connector.
2. Before installing the drain pipe fitting, appropriately plug all other base pan holes not used.
3. Install the drain pipe fitting into the appropriate hole located at the base of the unit and then connect the drain pipe to it.

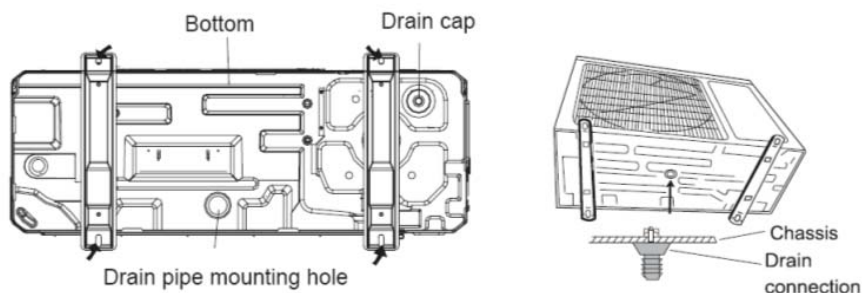

4. Place the outdoor unit on the support base.
5. Secure the foot holes of the outdoor unit with bolts (shown below).

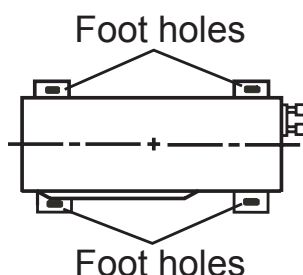

## Installing the Refrigerant Piping

### Flaring Process

1. Hold the pipe downward to prevent cuttings from entering the pipe.
2. Using an appropriate tube cutter and deburring tool, cut and deburr the refrigerant pipe.
3. Remove the flare nuts at the stop valve of the outdoor unit and inside the accessory bag of the indoor unit, put them onto the refrigerant pipe as shown below then flare the refrigerant pipe with a flaring tool.
4. When flaring copper tubing, only use flaring tools that utilize an orbiting mandrel and clutched handle. These are typically referenced as R410A flaring tools. By using this type of flaring tool, the copper tubing is rolled while being pressed, thereby reducing the probability of copper flare cracking.
5. Check if the flare part is spread evenly and there are no cracks.

### Bending Pipes

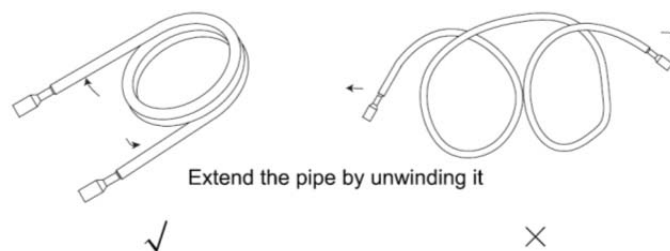

1. Use a refrigerant pipe bending tool to shape refrigerant piping; smaller diameter piping may allow for light hand bending, providing minimum diameter of 6 inches.
2. Do not bend the pipes in an angle more than 90°.
3. When pipes are repeatedly bent or stretched, the material will be prone to damage, which may lead to refrigerant leaks. Do not bend or stretch the pipes more than three times.

- Do not bend the pipe while insulated. First, cut the insulation with a sharp cutting tool and expose it to the appropriate bend radius, as shown below. After bending the pipe, replace the insulation and seal it with pipe wrap tape.

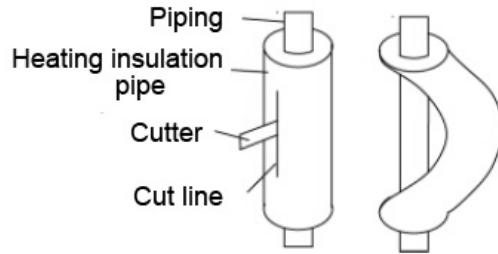

### NOTICE

- To prevent distortion and breaking of the pipe, bend the pipe with a radius of curvature of 6 in. (150 mm) or more. Use a tubing bender when forming the copper tubing into a bend.
- If the pipe is bent repeatedly at the same place, it will break.

### CAUTION

Connect the gas pipe after connecting the liquid pipe completely.

## Refrigerant Piping at the Outdoor Unit

Tighten the flare nut of the connection pipe at the outdoor unit valve connector. Follow the flare nut guidelines in this manual.

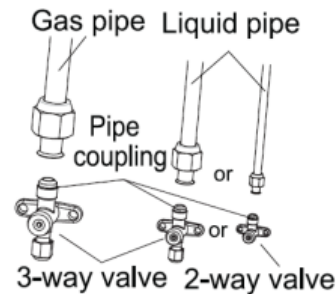

## Insulating the Refrigerant Piping and Connections

- The refrigerant pipes should be insulated and wrapped with appropriate insulating material and wrapping tape. This will prevent condensation, water leakage and damage to the insulating material.
- The connections at the indoor unit should be wrapped with insulating material. No gap is allowed on the joint of the indoor unit, as shown below.

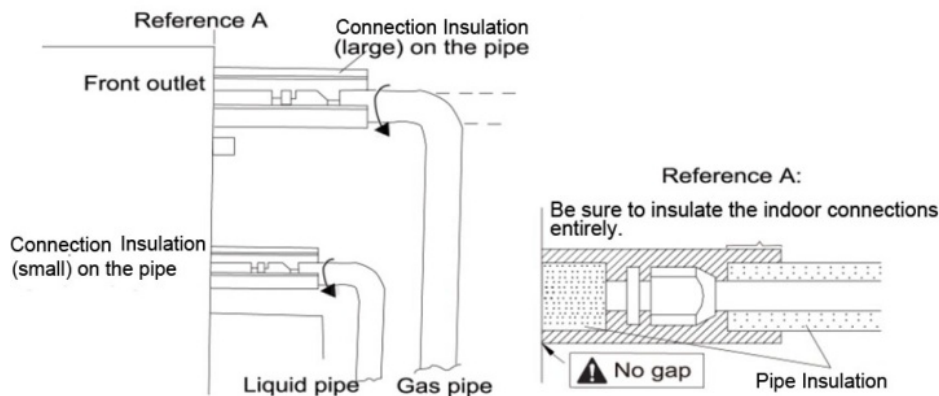

## Piping Requirements

### If the outdoor unit is installed lower than the indoor unit:

1. A drain pipe should be above ground and the end of the pipe should not dip into water.
2. Taping pipes must be done from bottom to top. Do not wrap too tightly to avoid compression of the insulation, otherwise its effectiveness is reduced.
3. All pipes are bound together by pipe tape and secured to the wall with saddles.
4. NOTE: Oil traps are sometimes needed when the outdoor unit is installed lower than the indoor unit. One oil trap is required for each 33 ft. (10m) of vertical gas pipe length.

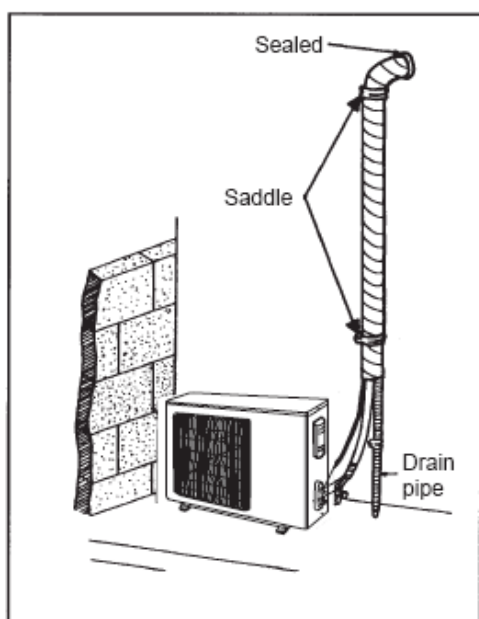

Outdoor Unit Installed Lower than Indoor Unit

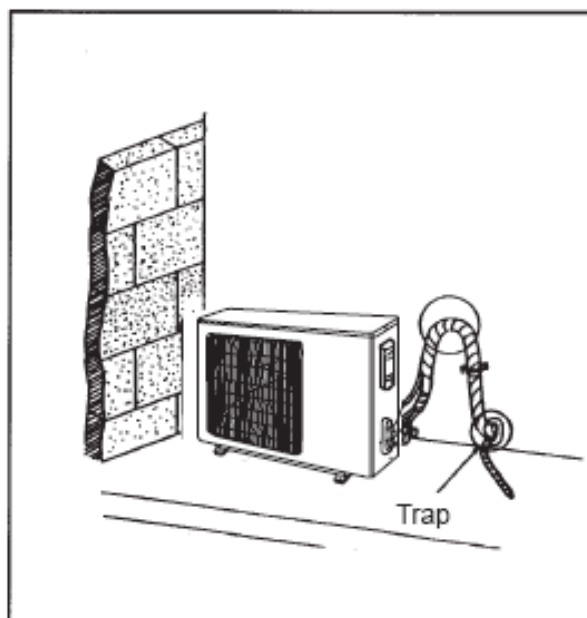

Outdoor Unit Installed Higher than Indoor Unit

### If the outdoor unit is installed higher than the indoor unit:

1. Taping should be done from the lower to the upper part. Do not wrap too tightly to avoid compression of the insulation, otherwise its effectiveness is reduced.
2. All pipes are bound and taped together and also should be trapped to prevent water from returning to the room.
3. Secure all pipes to the wall with saddles.
4. NOTE: Oil traps are sometimes needed when the outdoor unit is installed higher than the indoor unit. An oil trap is needed for each 20 ft. (6m) of vertical rise on the gas pipe.

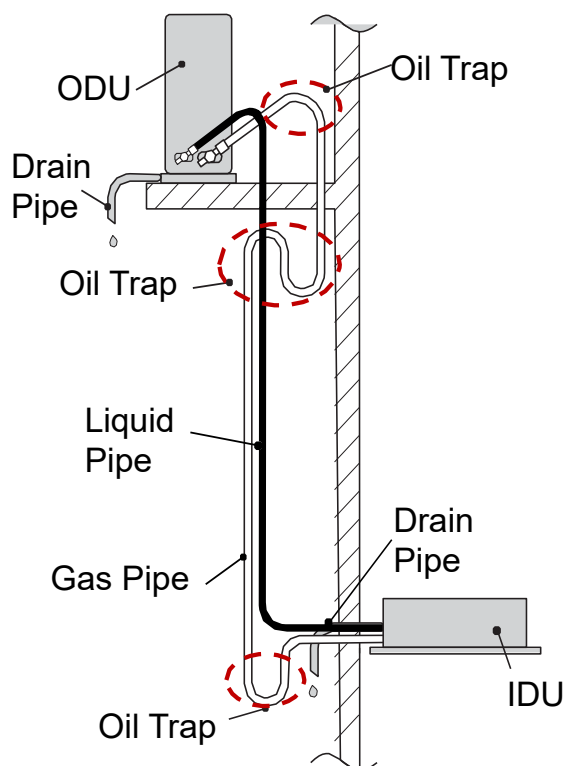

## Vacuum and Refrigerant Leakage Detection

### NOTICE

Do not purge the air with refrigerant. Use a vacuum pump to vacuum the installation!

1. When connecting refrigerant pipe to the unit or removing it from the unit, please use both a back-up wrench and the torque wrench.
2. When connecting, place the equipment specified oil type on the backside of the copper tube flare prior to tightening. Do not place oil on the flare face, as this will promote system contamination, tighten it by hand and then tighten it with the spanner or adjustable wrench.
3. Refer to the torque reference table within this document before tightening to determine the appropriate torque (over-tightening will damage the nut and lead to leakage).
4. Use dry Nitrogen to pressurize the piping circuit with 150 PSIG and allow it to hold while performing other installation processes. It is recommended to apply a soap bubble solution and observe the connection.
5. Evacuate each individual refrigeration circuit to 350 microns or below, and close off the valve to the vacuum pump. If the pressure rises above 500 microns within one minute, but not above 1500 microns within 5 minutes, moisture is present. If the pressure continues to rise above 1500 microns, a leak exists in the circuit being tested.
  - a) If moisture is present, use triple evacuation process to eliminate the moisture.
  - b) If a leak is present, leak check all joints and piping.Evacuation is not completed until the micron gauge does not rise above 500 microns within one minute after achieving 350 micron pressure vacuum.
6. After evacuation is complete, additional charge is to be added.
  - a) If no additional charge is required, break the vacuum with refrigerant, then remove the gauge connectors.
  - b) slightly open the liquid valve at the outdoor unit, allow system to equalize, then fully open the liquid valve and then open the vapor service valve.
7. After leak checking is complete, apply thermal insulation around the flare connections and all exposed refrigeration pipes.
  - a) Seal the insulation.
  - b) Inspect the insulation to ensure no breakages are present.

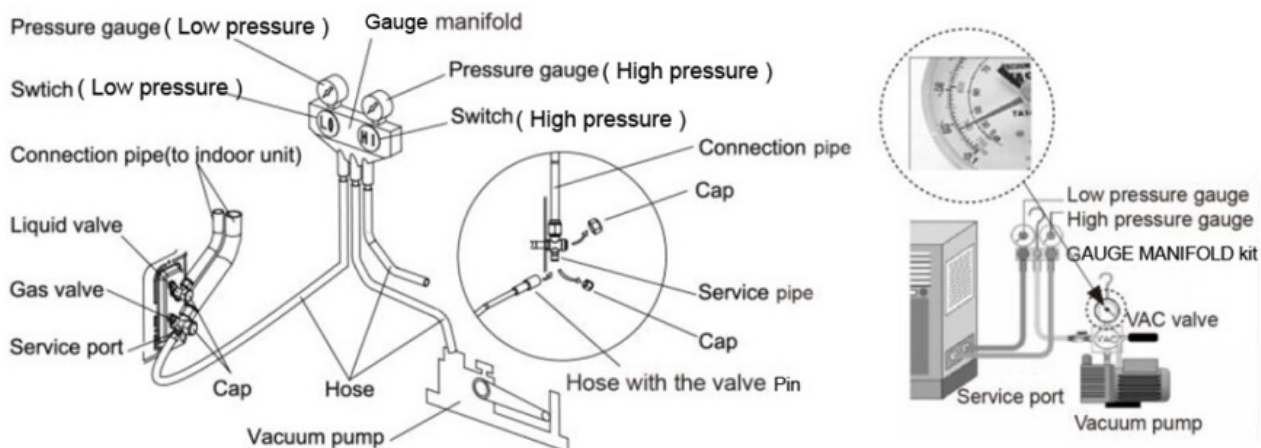



## Wiring Precautions



### WARNING

1. Before obtaining access to terminals, all supply circuits must be disconnected.
2. Improperly installed and grounded field wiring poses fire and electrocution hazards. For high voltage connections, flexible electrical conduit is recommended whenever vibration transmission may create a noise problem within the structure. To avoid these hazards, you **MUST** follow requirements for field wiring installation and grounding as described in the National Electrical Codes (NEC) and your local/state electrical codes. All field wiring **MUST** be performed by qualified personnel. Failure to follow these requirements could result in death or serious injury.

### Electrical Notes:

1. EACH unit should be installed with its own dedicated power supply source. The power source needs to be sized correctly for the unit capacity.
2. The rated voltage of the unit is as shown in this manual.
3. Before turning on, verify that the voltage is within the 187~252 V range (for 208/230 V, single phase units).
4. Always use a grounded terminal and install a separate receptacle to supply power to the air conditioner. For high voltage connections, flexible electrical conduit is recommended whenever vibration transmission may create a noise problem within the structure.
5. Use a dedicated breaker and receptacle matched to the capacity of the air conditioner.

## Outdoor Wiring Connections

1. Remove the wire clip and connect the power connection wire and signal control wire terminals according to the color coding.
2. Attach the wires to the terminals and make sure they are securely fastened. Refer to wiring diagrams in this manual. An example is provided in the figure below:

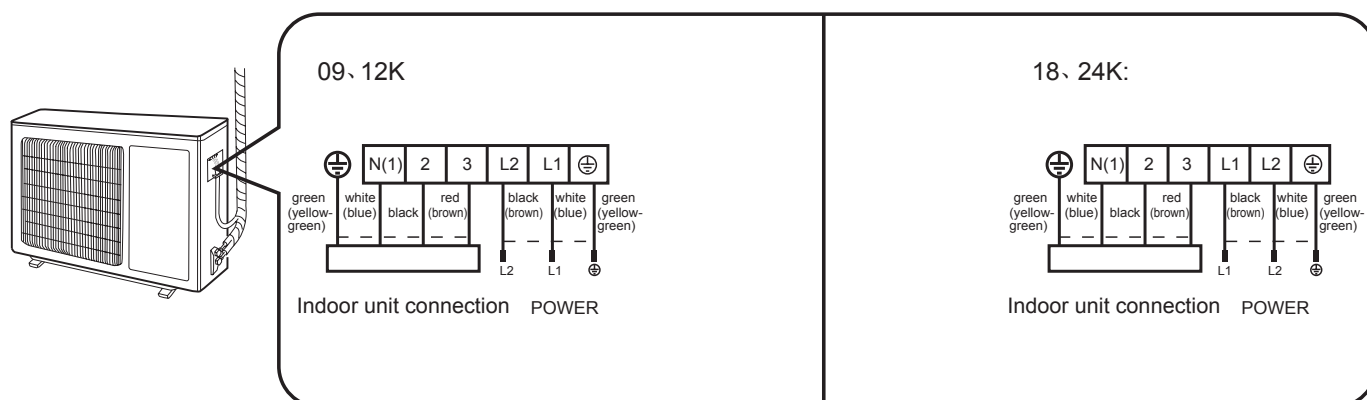

**NOTE:** The wiring diagrams in this guide are included as a reference. The manufacturer has a policy of continuous product and product data improvement and reserves the right to change design and specifications without notice. Always check the unit nameplate and wiring diagram for the actual unit requirements.

## Stranded Wiring Connections

Cut the wire end with a wire cutter or wire cutting pliers, then strip the insulation about 3/8" (10mm).

1. Using a screwdriver, remove the terminal screw(s) on the terminal board.
2. Using a round terminal fastener or pliers, securely clamp a round terminal to each stripped wire end.
3. Position the round terminal wire, and replace and tighten the terminal screw with a screwdriver.
4. Affix and secure the power supply and connection wiring under unit wiring clamps.

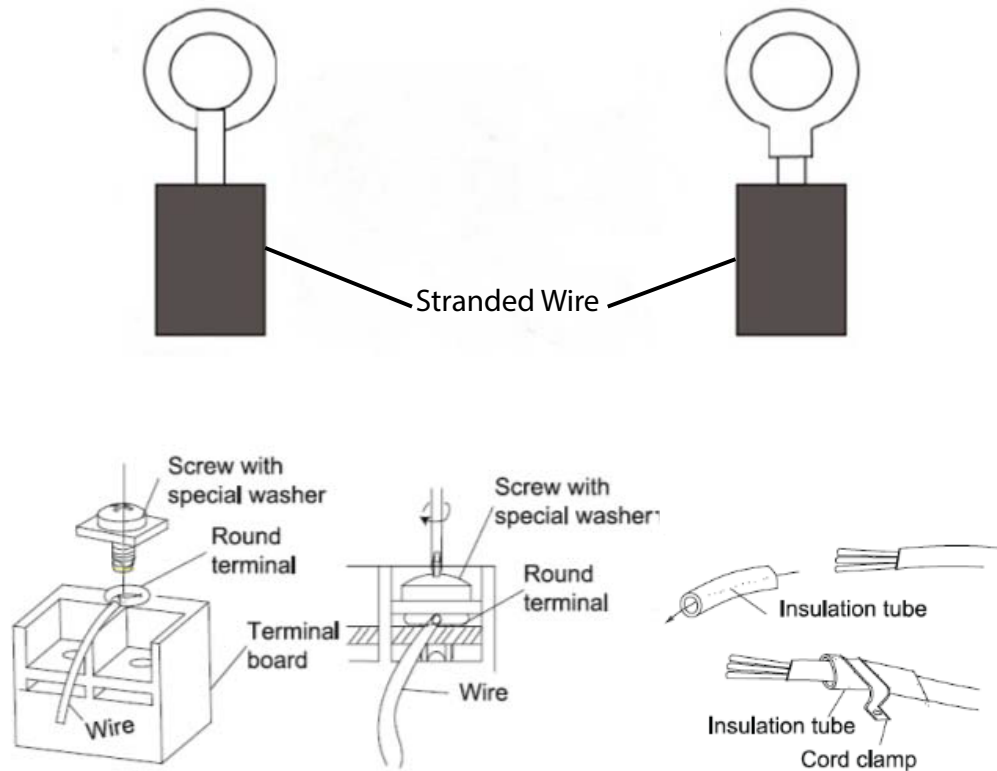

### WARNING

1. Ensure power supplied to the equipment (both indoor and outdoor units) is disconnected and the units are not energized prior to performing work on the system.
2. Improperly installed field wiring poses fire and electrocution hazards. Install wiring carefully.
3. Secure the connection wires firmly to the terminal block. Improper installation may cause a fire.
4. Always fasten the outside covering of the connection wire with wire clamps. If the insulator is not clamped, electric leakage may occur.
5. Always completely connect the ground wire.

### Note:

Match the terminal block numbers and connection wire colors with those of the indoor units.

## Electrical Connections

<b>CAUTION</b>
Improper operation may lead to personal injury or property damage.
Size the power supply wiring according to the NEC, local code and the MCA indicated on the unit nameplate.

### Electrical Requirements

Heat Pump Models	M4THS1709	M4THS1712	M4THS1718	M4THS1724
Cooling Models	M4TCS1709	M4TCS1712	M4TCS1718	M4TCS1724
Power Supply	208/230V, 60Hz, 1phase			

1. Always check the unit nameplate for the MCA and MOP requirements.
2. The fuse is located on the main electrical board.
3. A dedicated indoor unit disconnect switch and power supply circuit may need to be installed if local codes or jurisdictions require it. Otherwise, the indoor unit is powered directly from the outdoor unit.
4. Install a separate disconnect at the outdoor unit. The power supply, wiring and grounding of equipment must comply with National, State and/or local codes. The power supply must match with the equipment nameplate specification.
5. Improperly installed and grounded field wiring poses fire and electrocution hazards. For high voltage connections, flexible electrical conduit is recommended whenever vibration transmission may create a noise problem within the structure. To avoid these hazards you **MUST** follow requirements for field wiring installation and grounding as described in the National Electrical Codes (NEC) and your State and/or local electrical codes. All field wiring **MUST** be performed by qualified personnel. Failure to follow these requirements could result in death or serious injury.
6. The wiring, including the ground wire, between the indoor and outdoor units should be at least 14 AWG, 600 volt rated, stranded wire, with an absolute maximum length of 230 ft. (70m). Shorter lengths result in more robust communication between the indoor and outdoor unit. Please select an appropriate length for the installation conditions. The wires cannot be cut and spliced together.
7. For the wired controller: The communication distance between the main board and the wired controller can be up to 65 ft. (19.8m). The standard distance is 25 ft. (7.6m).

### Power Supply Wiring

1. Open the side covering plate.
2. Connect the power wiring to the terminals "L1", "L2" and also to the grounding bolt, and then connect the wiring terminals "N(1), 2, 3" of the indoor unit to those of the outdoor unit correspondingly.
3. Fix the power wiring with wire clips.
4. Run the power wiring through conduit (as required by NEC) attached to the round electrical connection ports.

**Note:** When connecting the power supply wiring, make sure that the phase of the power supply matches with the voltage and phase on the nameplate, If not, the compressor will run improperly.

### Cable Specifications

The wiring, including the ground wire, between the indoor and outdoor units should be at least 14 AWG, 600 volt rated, stranded, four conductor wire, with an absolute maximum length of 230 ft. (70m). Shorter lengths result in more robust communication between the indoor and outdoor unit. Please select an appropriate length according to the installation conditions. The wires cannot be cut and spliced together.

Consult local and regional codes, as well as the NEC, for installation requirements that are applicable to the selected type of cable including watertight conduit and raceway requirements.

Power supply wiring should be installed according to the NEC, local and regional codes. Refer to the equipment nameplate for electrical requirements.

### Grounding Requirements

- Follow your local, State and National Electric Codes (NEC) when grounding this unit.
- The air conditioner is classified as a Class I appliance and must be grounded.
- The yellow-green wire of the air conditioner is the ground wire and cannot be used for other purposes or cut off, otherwise it would create an electric shock hazard.
- Do not ground the unit to a utility pipe, arrester or telephone ground. Incomplete ground may cause electrical shock or fire. A high current surge from lightning or other sources may cause damage to the air conditioner.

### Installation of Controllers

Refer to the controller installation manual for instructions and functionality.

## Post Installation Checklist

Check the following points before testing the unit:

NO.	Item to be checked	Possible problem
1	Have the indoor and outdoor units been securely installed?	The units may fall, vibrate or make noise.
2	Has the refrigerant leak test been completed?	Unresolved leaks may cause insufficient cooling or heating.
3	Have the pipes been properly insulated?	Lack of insulation may cause condensation and water damage.
4	Is the water condensate drainage sufficient?	Lack of proper drainage may cause condensation and water damage.
5	Does the voltage of the power supply comply with the voltage on the nameplate?	Incorrect power supply can create malfunction and fire or electrocution hazard.
6	Is the electric wiring and drain piping installed correctly?	Improper wiring and drainage can create a malfunction, fire or electrocution hazard and water damage to the unit and property.
7	Is the unit grounded properly?	Improper grounding can cause malfunction and fire or electrocution hazard.
8	Does the power wiring match the unit requirements?	Improper wiring can create malfunction and fire or electrocution hazard.
9	Are there any obstructions near the air inlets and air outlets for the indoor and outdoor units?	Improper ventilation and airflow will cause insufficient cooling and heating and possible freezing and condensate issues at the indoor unit.
10	Have dust and debris been cleaned and removed from the installation site?	Excessive dust and debris in and around the units may cause a malfunction or damage to the units.
11	Are the gas valve and liquid valve of the connection pipes open completely?	Restricted refrigerant flow may cause insufficient cooling or heating.

### Test Operation:

1. Turn on main power to the units.
2. Using the remote control, press the ON/OFF button to start operation.
3. Press the MODE button to select and test each option for normal operation. Cycle through all functions: AUTO, COOL, DRY, FAN and HEAT (heat pump models only).
4. Note: When conducting this test, be mindful of the modes of operation and the ambient temperature ranges specified in this manual.
5. Instruct the end-product user about basic operating, maintenance and troubleshooting functions.

# Refrigerant System Diagram

## Cooling Only Models

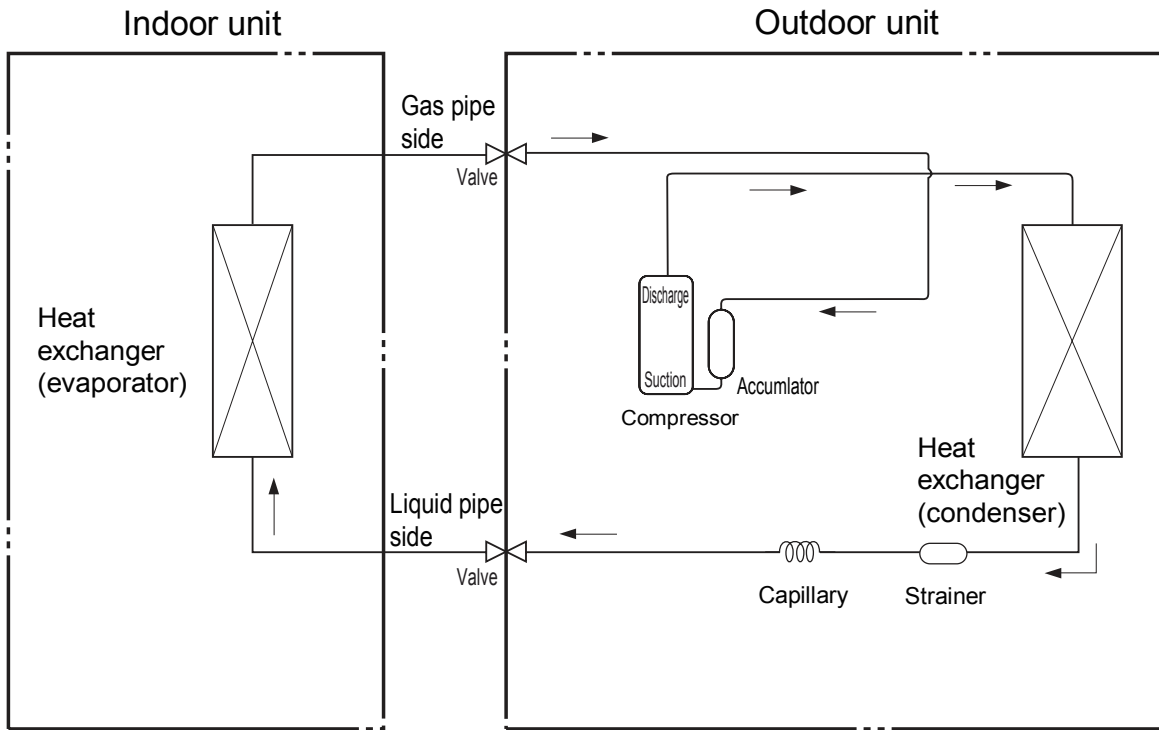

## Heat Pump Models

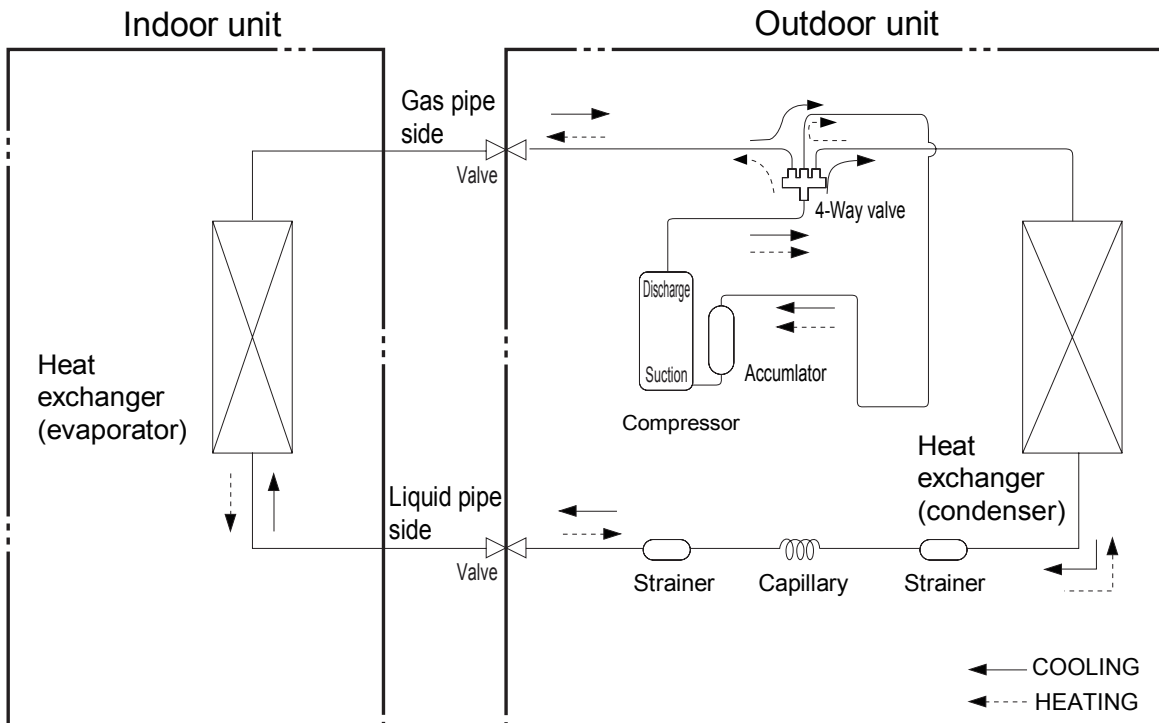

Connection pipe specification:  
 Liquid pipe: 1/4" inch (all models)  
 Gas pipe: 3/8" (for 9-12K)  
 Gas pipe: 1/2" (for 18K)  
 Gas pipe: 5/8" (for 24K)

## Wiring Diagrams

### Color Key

Symbol	Symbol Color	Symbol	Symbol Color	Symbol	Name
WH	White	GN	Green	CAP	Jumper cap
YE	Yellow	BN	Brown	COMP	Compressor
RD	Red	BU	Blue		Grounding wire
YE/GN	Yellow/Green	BK	Black	/	/
VT	Violet	OG	Orange	/	/

Note: Jumper cap is used to determine fan speed and the swing angle of horizontal louver for this model. The unit will not operate without the correct jumper cap. When replacing boards the jumper cap must be moved to the new board.

### Indoor Unit

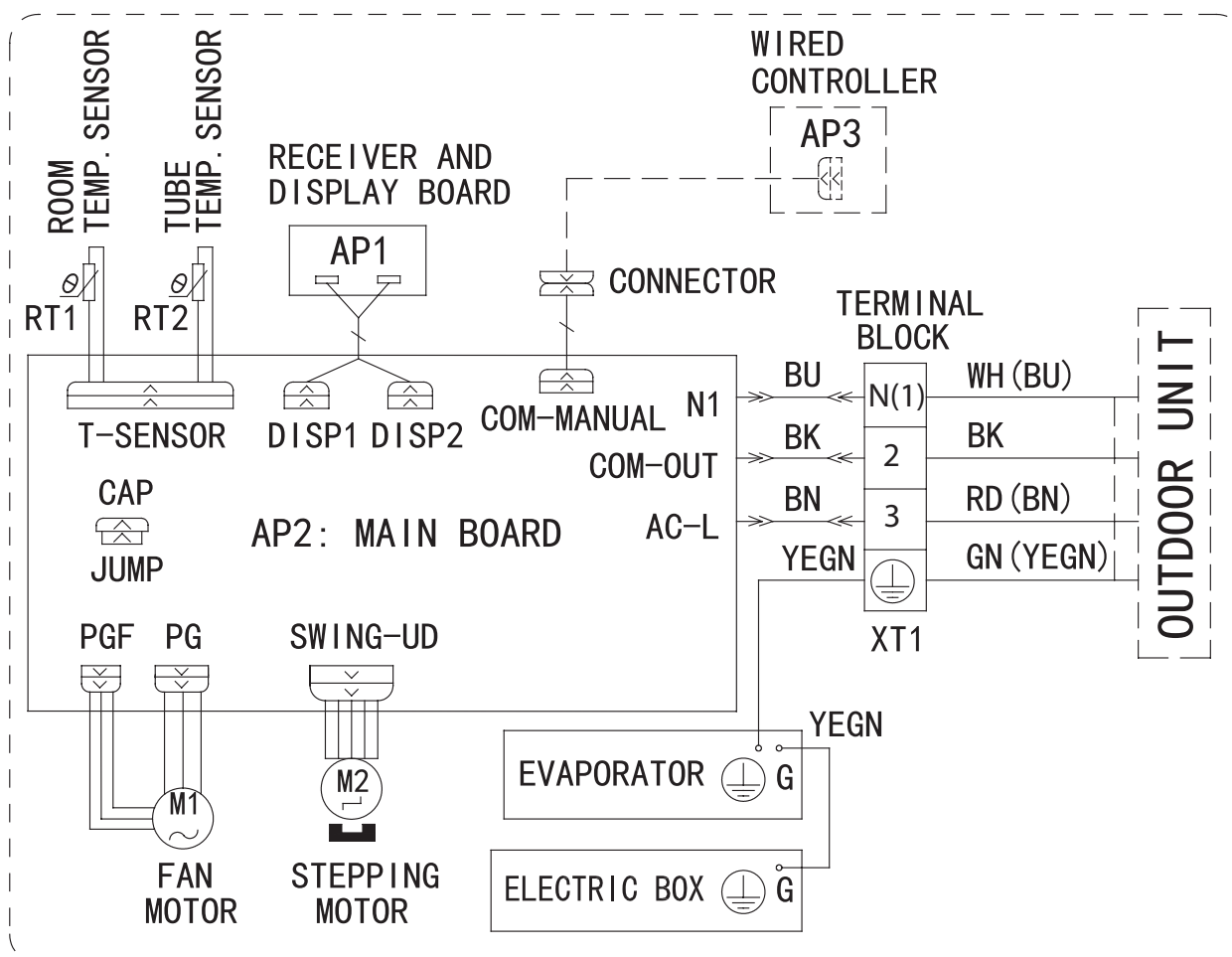

**NOTE:** The wiring diagrams in this guide are included as a reference. The manufacturer has a policy of continuous product and product data improvement and reserves the right to change design and specifications without notice. Always check the unit nameplate and wiring diagram for the actual unit requirements.

Outdoor Cooling Only Unit 9K-12K

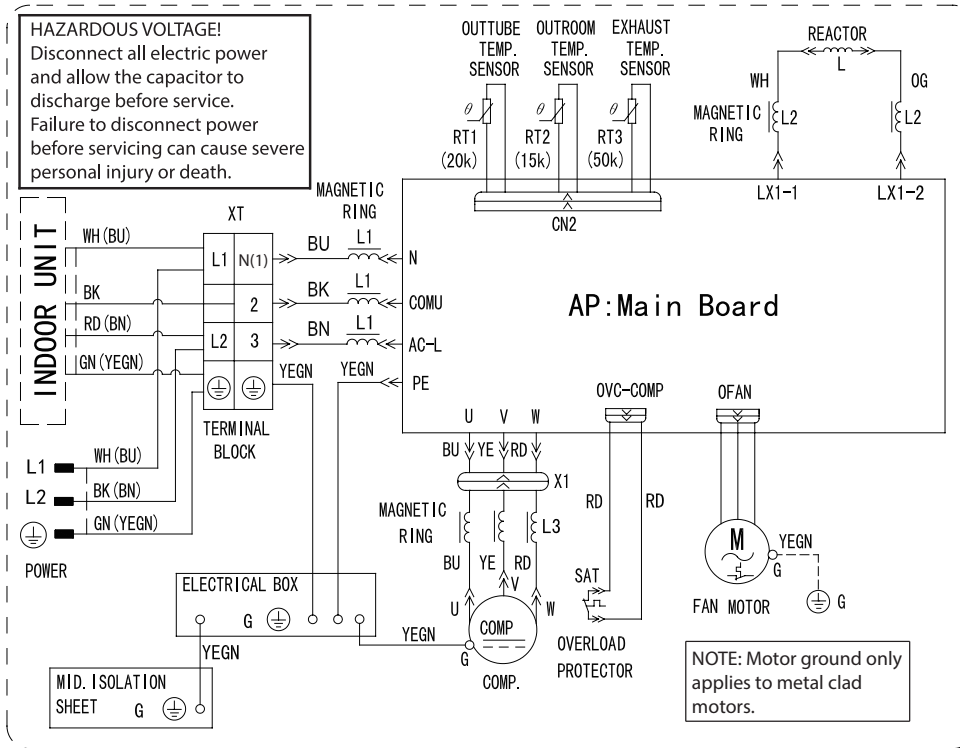

Outdoor Heat Pump Only Unit 9K-12K

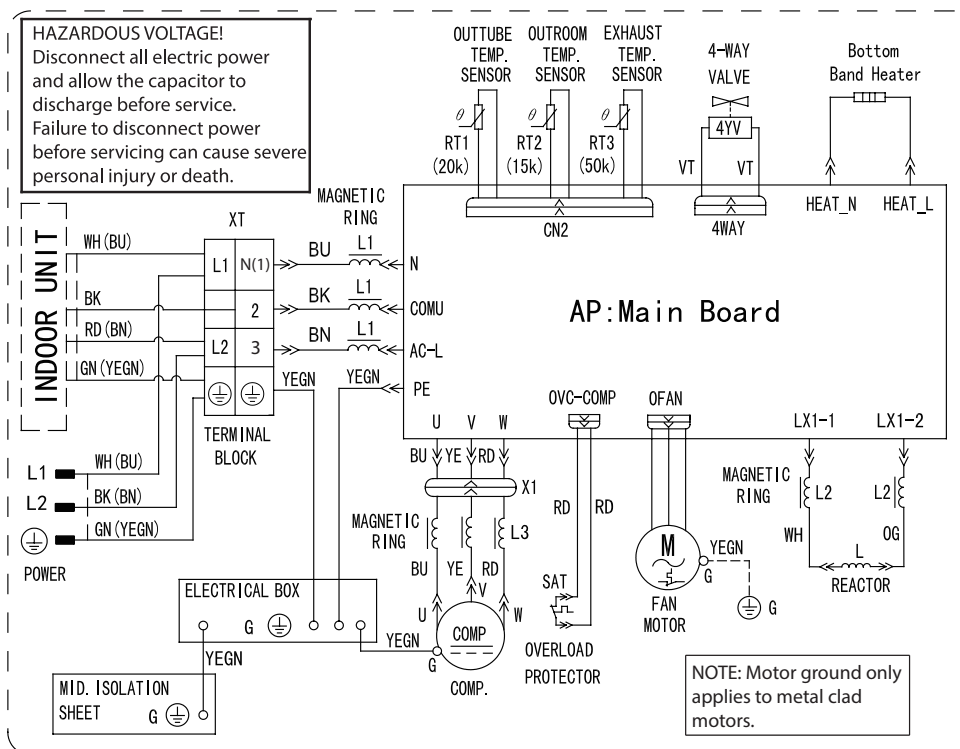

These diagrams are subject to change without notice, please refer to the diagram supplied with the unit.

**NOTE: The wiring diagrams in this guide are included as a reference. The manufacturer has a policy of continuous product and product data improvement and reserves the right to change design and specifications without notice. Always check the unit nameplate and wiring diagram for the actual unit requirements.**



### Outdoor Cooling Only Unit 18K-24K

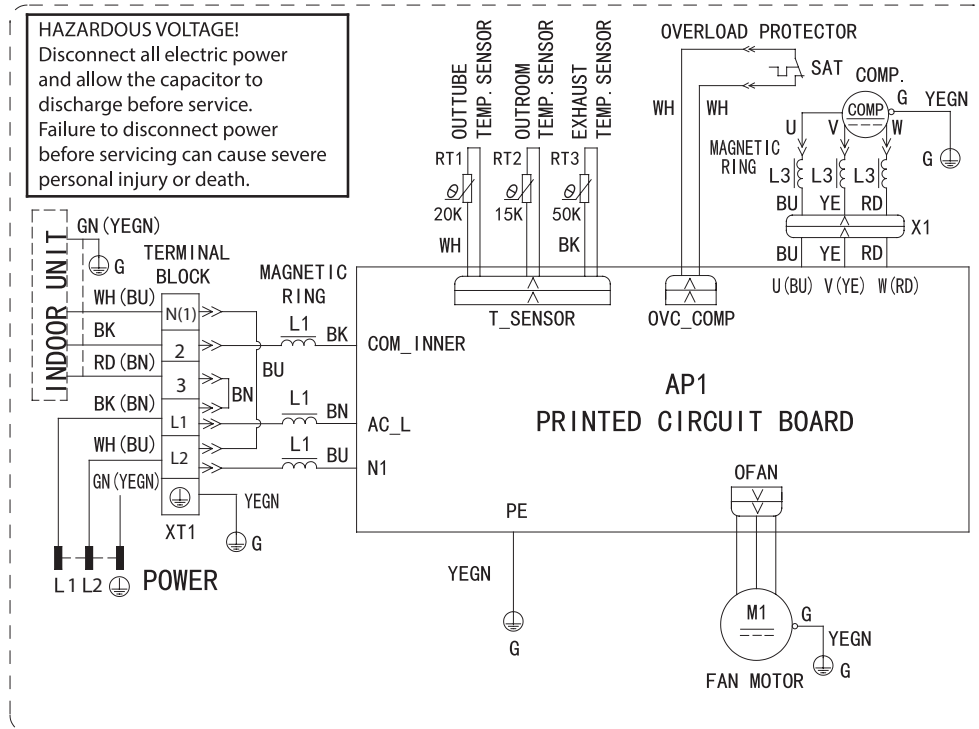

### Outdoor Heat Pump Only Unit 18K-24K

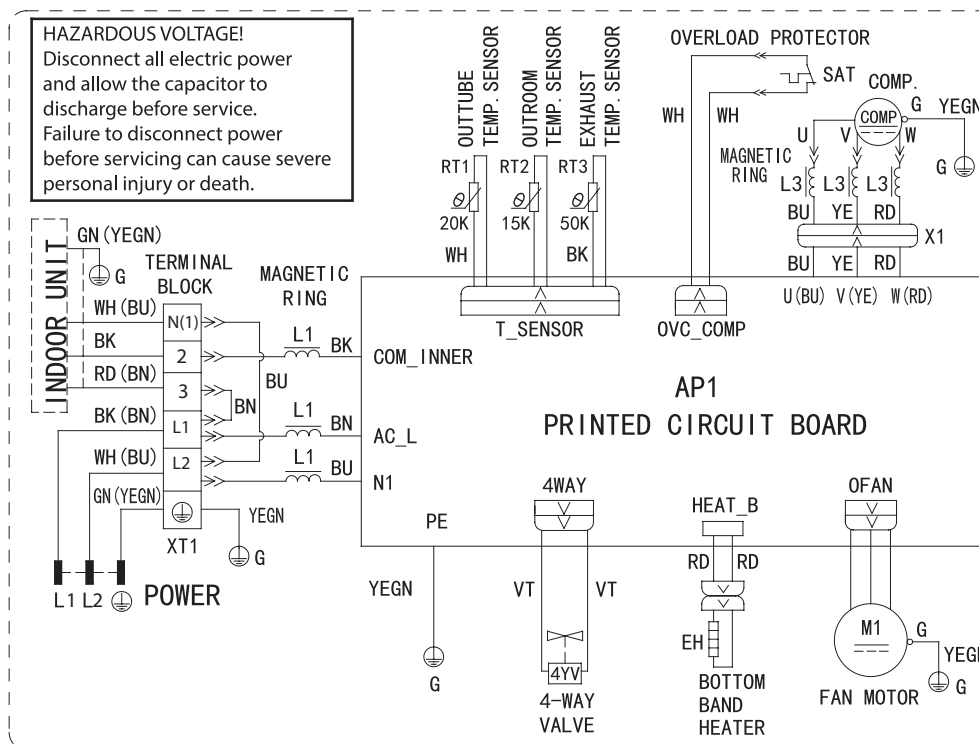

These diagrams are subject to change without notice, please refer to the diagram supplied with the unit.

**NOTE:** The wiring diagrams in this guide are included as a reference. The manufacturer has a policy of continuous product and product data improvement and reserves the right to change design and specifications without notice. Always check the unit nameplate and wiring diagram for the actual unit requirements.

# Indoor Unit Dimensions

## 9K-12K Indoor Units

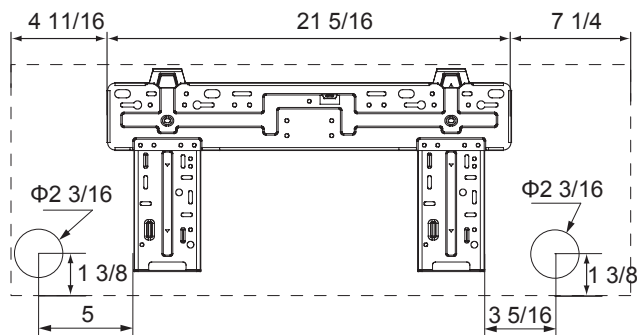
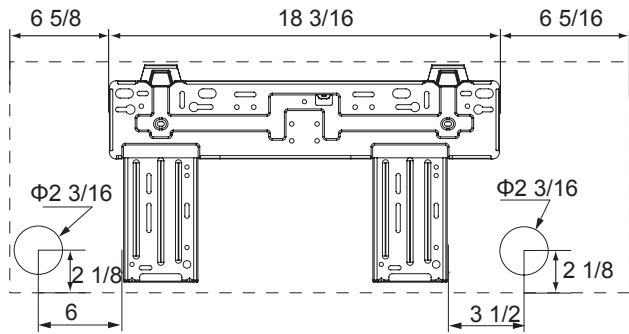
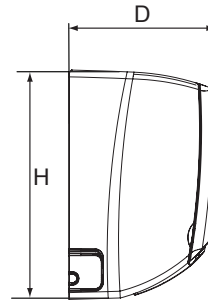
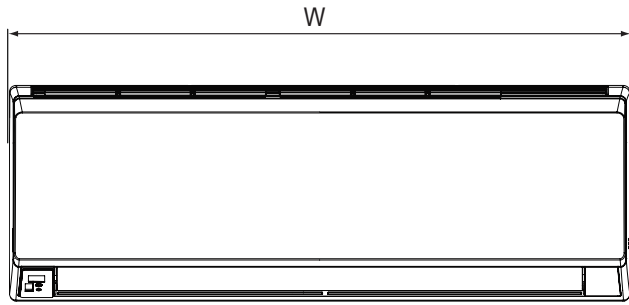

The dimensions in these drawings are rounded according to standard measurement.

Unit:inch

MODEL	W	H	D
09K	31 1/8	10 5/8	7 7/8
12K	33 1/4	11 3/8	8 1/4

# Indoor Unit Dimensions, continued

## 18K-24K Indoor Units

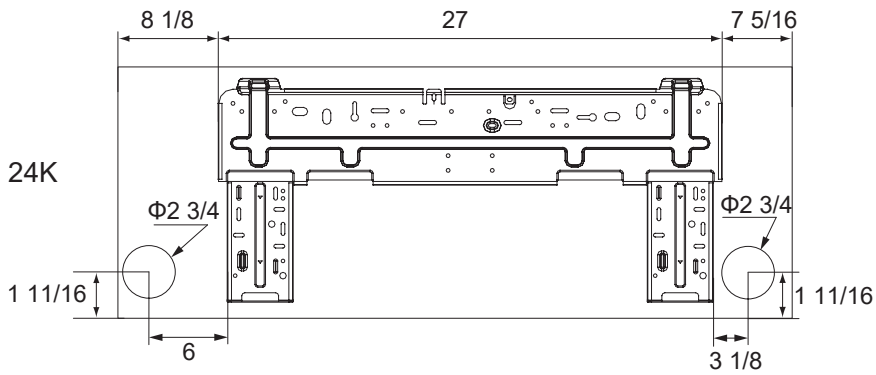
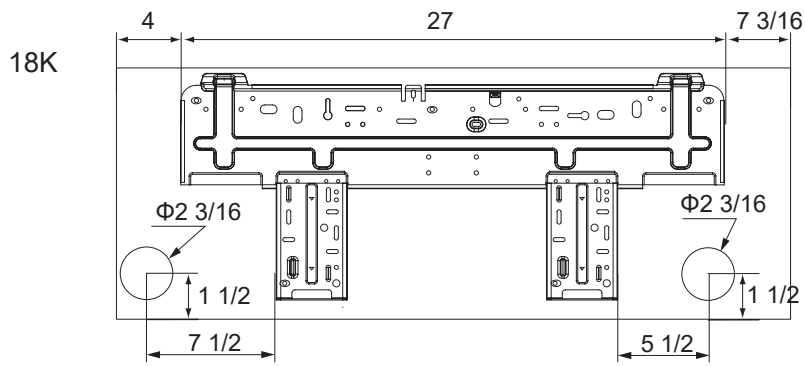
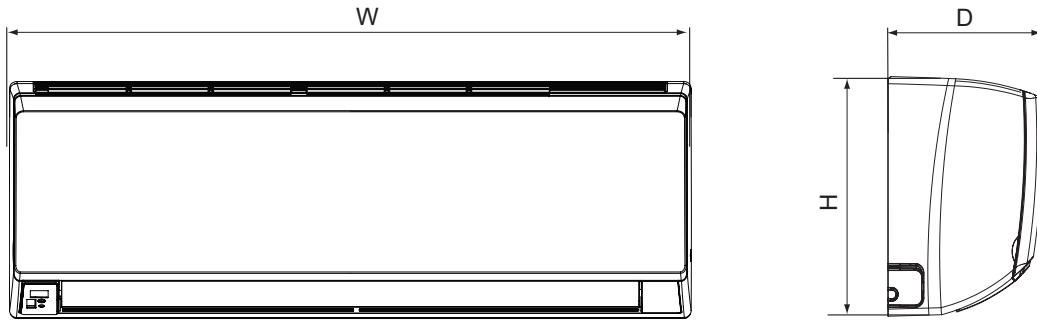

Unit:inch

The dimensions in these drawings are rounded according to standard measurement.

Models	W	H	D
18K	38 1/4	11 13/16	8 7/8
24K	42 1/2	12 13/16	9 11/16

## Outdoor Unit Dimensions

### 9K-12K Outdoor Units

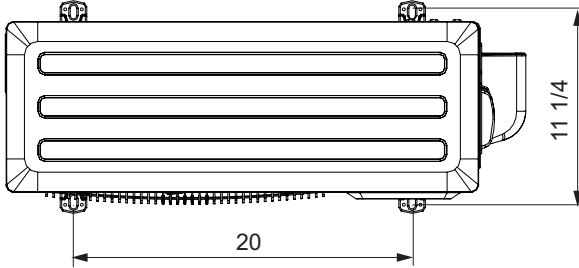
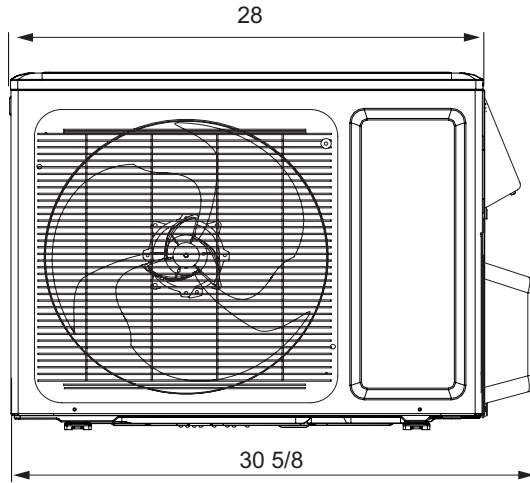
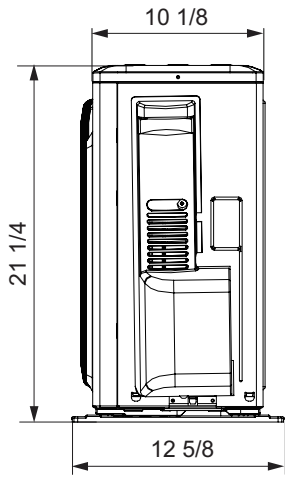

The dimensions in these drawings are rounded according to standard measurement.

### 18K-24K Outdoor Units

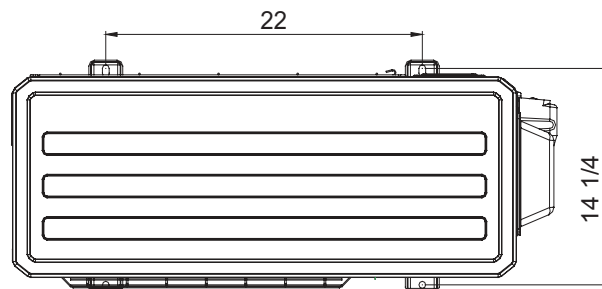
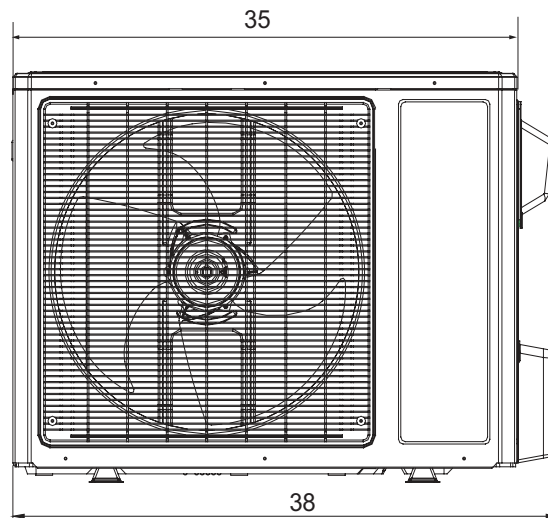
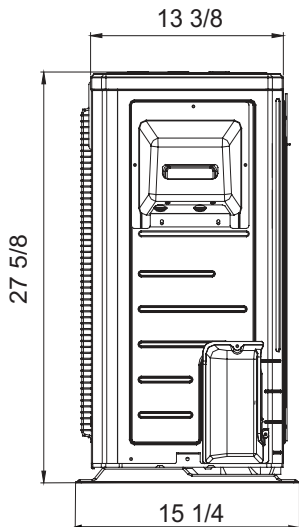

Unit: inch

## Common Error Codes

Error Codes	Malfunction Type	Possible Causes
<b>C5</b>	System Configuration Malfunction	<ol style="list-style-type: none"> <li>1. Jumper cap missing from the control board.</li> <li>2. Incorrect or damaged jumpercap on control board.</li> <li>3. Indoor and outdoor units are not compatible.</li> </ol>
<b>E1</b>	High Pressure	<ol style="list-style-type: none"> <li>1. Overcharged with refrigerant.</li> <li>2. Blocked or dirty outdoor coil.</li> <li>3. Extreme outdoor ambient conditions.</li> </ol>
<b>E2</b>	Indoor Anti-Freeze Protection	<ol style="list-style-type: none"> <li>1. Low return airflow.</li> <li>2. Indoor fan speed is too low.</li> <li>3. Indoorcoil is blocked or dirty.</li> </ol>
<b>E4 / E8</b>	High Temperature Resistant Protection	<ol style="list-style-type: none"> <li>1. Incorrect refrigerant charge level.</li> <li>2. Refrigerant metering device malfunction.</li> <li>3. Compressor malfunction.</li> </ol>
<b>E5</b>	Overcurrent Protection	<ol style="list-style-type: none"> <li>1. Supply voltage is unstable.</li> <li>2. Supply voltage is too low and system load is too high.</li> <li>3. Indoorcoil is blocked or dirty.</li> </ol>
<b>E6</b>	Communication Malfunction	<ol style="list-style-type: none"> <li>1. Communication cable is mis-wired between indoor and outdoor units.</li> <li>2. Indoor or Outdoor control board malfunction.</li> </ol>
<b>F0</b>	Refrigerant Leakage Protection	<ol style="list-style-type: none"> <li>1. Refrigerant leak(s).</li> <li>2. Indoor coil temperature sensor out of calibration.</li> <li>3. Refrigerant flow is restricted (ex. valve, exv, debris)</li> </ol>
<b>F1</b>	Indoor Ambient Temperature Sensor Malfunction	<ol style="list-style-type: none"> <li>1. Measure sensor resistance.</li> <li>2. Discharge temperature sensor damaged.</li> <li>3. Loose or bad connection between sensor and control board.</li> </ol>
<b>F2</b>	Indoor Coil Temperature Sensor Malfunction	
<b>F3</b>	Outdoor Ambient Temperature Sensor Malfunction	
<b>F4</b>	Outdoor Coil Temperature Sensor Malfunction	
<b>F5</b>	Outdoor Discharge Temperature Sensor Malfunction	
<b>H3</b>	Compressor Overload Protection	<ol style="list-style-type: none"> <li>1. Wiring terminal OVC-COMP is loose.</li> <li>2. Compressor has reached 239°F.</li> </ol>

Error Codes	Malfunction Type	Possible Causes
<b>H5</b>	IPM Module Protection	<ol style="list-style-type: none"> <li>1. Improper or low voltage at the IPM module.</li> <li>2. IPM module malfunction.</li> <li>3. Compressor Malfunction.</li> </ol>
<b>H6</b>	Indoor DC Fan Motor Malfunction	<ol style="list-style-type: none"> <li>1. Loose connections between fan motor and control board.</li> <li>2. Fan motor or blower wheel bearings malfunction.</li> <li>3. Control board malfunction.</li> </ol>
<b>H7</b>	Compressor De-Synchronized Malfunction	<ol style="list-style-type: none"> <li>1. Unbalanced compressor voltage.</li> <li>2. Control board malfunction.</li> <li>3. Compressor malfunction.</li> </ol>
<b>L3</b>	Outdoor Fan Motor Malfunction	<ol style="list-style-type: none"> <li>1. Loose connections between fan motor and control board.</li> <li>2. Fan motor malfunction.</li> <li>3. Control board malfunction.</li> </ol>
<b>LP</b>	Mismatched Indoor and Outdoor Units	Indoor and outdoor units are non-compatible.
<b>P8</b>	Module Temperature Protection	<ol style="list-style-type: none"> <li>1. Lack of thermal grease on IPM module.</li> <li>2. Heat sink (radiator) not tightly mounted.</li> <li>3. Control board malfunction.</li> </ol>
<b>U4</b>	Reversing Valve Malfunction	<ol style="list-style-type: none"> <li>1. Reversing valve voltage is less than 175V.</li> <li>2. Loose connections between reversing valve and control board.</li> <li>3. Reversing valve solenoid malfunction.</li> </ol>

**If other error codes are present, contact your dealer or qualified service technician.**

If any of the following occurs, shut off the unit and contact your dealer or qualified service technician:

- Power cord overheats or becomes damaged
- If you notice a burning smell
- The unit trips the breaker panel or cycles off frequently without obtaining the set temperature
- Abnormal sound during operation
- If you notice water leakage

## Troubleshooting



### WARNING

Improper operation may lead to personal injury or casualty.

- Turn off the main power switch immediately if a malfunction is detected. Contact the installing dealer or qualified service technician. If the unit continues to run during a malfunction, the unit may be damaged or electric shock or fire may occur.
- Do not try to move or reposition the units. Please contact the servicing/installing dealer to repair or move the units.
- Check the following items before contacting the dealer or qualified service technician.

Condition		Possible Reason
Unit doesn't run	When unit is started immediately after it is just turned off	Overload protection switch delays unit start up for three minutes
	When power is turned on	The unit is in standby for one minute
Mist comes from the unit	When cooling cycle starts	Indoor high humidity air is cooled rapidly
Sound comes from the unit	Slight cracking sound is heard when unit starts	This sound occurs when the electronic expansion valve initializes.
	There is sound when cooling	The sound of gas refrigerant flowing in unit
	There is sound when unit starts or stops	This sound occurs when gas refrigerant starts or stops flowing.
	There is slight sound when unit is running or after running	The sound of the drainage system operating.
	Cracking sound is heard when unit is operating and after operating	This sound occurs when the unit panels expand or contract due to temperature change.
The unit blows out dust	When the unit has been off for a period of time.	Dust in indoor unit is blown out
The unit emits odor	When the unit is operating	The room odor absorbed by the unit is blown out again
Indoor unit still runs after switch off	After every indoor unit receives the "stop" signal, fan will keep running	Indoor fan motor will keep running 20-70 seconds to use excess cooling and heating and prepare for the next operation
Mode conflict	COOL or HEAT mode can not be operated	When the indoor operating mode conflicts with that of the outdoor unit, the indoor fault indicator will flash and conflict will be shown on the wired controller after 5 minutes. Indoor unit stops running and the outdoor unit changes its mode of operation to match the indoor unit, then the unit will go back to normal. COOL mode doesn't conflict with DRY mode. FAN mode doesn't conflict with any mode.

**NOTE:** If the problem persists after checking the above items and taking appropriate measures, please stop operation of the unit immediately and contact your local service agency or dealer. Diagnostics and repairs should be completed by a professional service technician.

### Auxiliary Operation

If the remote controller is lost or damaged, please use the auxiliary button to turn on or turn off the air conditioner. Open the front panel of the unit and press the aux. button to turn on or turn off the unit. When the unit is operated by the auxiliary button it will run only in auto mode.

Note: Auto mode operation - 77°F is the set temperature for cooling operation and 68°F is the set temperature for heating operation. There is no adjustment available for auto mode operation.

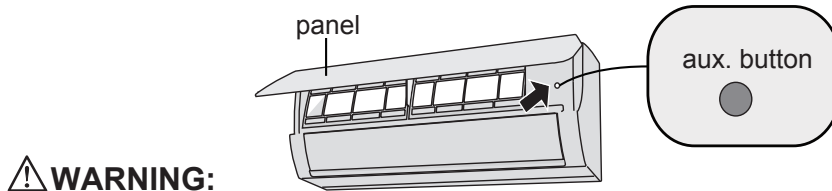

**⚠ WARNING:**

Use an insulated object such as an electrician's screwdriver to press the aux. button.

### Indoor Unit Maintenance

1. Clean the outer surface of the unit with a dry or damp cloth.
2. If there is residue, the unit may be cleaned with a mild detergent solution. Do not use chemical solvents or flammable liquids to clean the surface of the unit. Wipe dry after cleaning with a soft dry cloth.
3. Clean the filter a minimum of every three months. Clean more often if it is in an area that is dusty or smoky.
4. Open the front outer panel of the indoor unit.
5. Remove the filter by grasping the edges and pulling downward.
6. Clean the filter using a vacuum or rinse under cool, clear water.
7. If the filter is very dirty, use warm water (below 115°F/ 45°C). A mild detergent should only be used if the residue cannot be removed with warm water. Rinse the filter thoroughly before allowing to air dry. If the filter cannot be adequately cleaned, contact your dealer for a replacement filter.
8. Let the filter air dry to avoid warping. Do not dry the filter in direct sunlight.
9. Reinstall the filter into the clips and close the front panel.

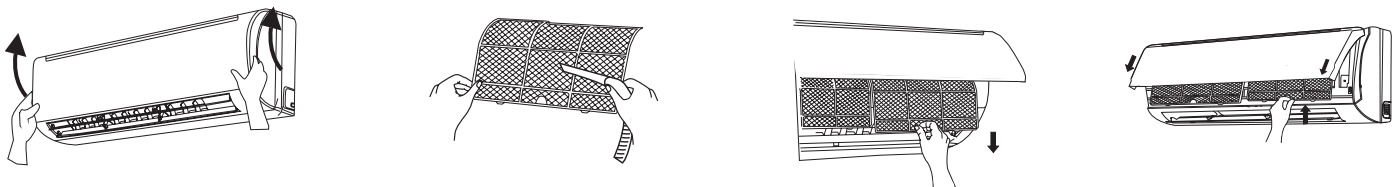

**⚠ WARNING**

1. After removing the filter, do not touch the evaporator fins to avoid injury.
2. Do not use fire, a hair dryer or any other source of heat to dry the filter to avoid a fire hazard and warping.



---

## General Maintenance

Regular checks, maintenance and care should be performed by professional personnel, which will prolong the unit life span.

### Outdoor Heat Exchanger

The outdoor heat exchanger should be checked and cleaned once every two months. Use a vacuum cleaner with a nylon brush to clean up dust and debris on the surface of the heat exchanger. Blow away dust by compressed air if available. Never use water to wash the heat exchanger.

### Drain Pipe

Regularly check to see if the drain pipe is clogged in order to ensure drain condensate doesn't overflow and cause water damage.

### Check Before Seasonal Use

1. The inlet and outlet of the indoor and outdoor units are not clogged or obstructed.
2. The power and communication cables are securely attached and that there is no visible damage to any of the electrical wiring.
3. The batteries of the wireless remote controller have been replaced.
4. The filter screen has been cleaned and replaced securely.
5. After long periods of shutdown, open the main power switch 8 hours before operating the unit so as to preheat the compressor.
6. The outdoor and indoor units are installed securely.
7. If there is anything abnormal, please contact the installing dealer or qualified service technician.

### Maintenance After Seasonal Use

1. Cut off the main power supply of the unit. A power disconnect should be located near the outdoor unit.
2. Clean the indoor unit filters.
3. Clean any dust and debris on the indoor and outdoor units.
4. In the event of rusting, use anti-rust paint to stop spreading of rust.

### Parts Replacement

Purchase parts from the installing or servicing center or dealer if necessary.

NOTE: During leakage testing, never mix oxygen, ethyne (acetylene) or other dangerous gases into the refrigeration circuit. Nitrogen should be used for leakage testing.

### After-Sales Service

In the event you have problems with the unit or require service, please contact your local installing/servicing dealer.

About Trane and American Standard Heating and Air Conditioning  
Trane and American Standard create comfortable, energy efficient indoor environments for residential applications.  
For more information, please visit [www.trane.com](http://www.trane.com) or [www.americanstandardair.com](http://www.americanstandardair.com)

---



The AHRI Certified mark indicates company participation in the AHRI Certification program. For verification of individual certified products, go to [ahridirectory.org](http://ahridirectory.org).

The manufacturer has a policy of continuous data improvement and it reserves the right to change design and specifications without notice. We are committed to using environmentally conscious print practices.