

iWave®-R

Residential Air Cleaner

Mounting Options

Fan Inlet Mount

- Internal magnets holding unit to fan inlet (shaft side).
- Use self-tapping screws to secure device, especially for high velocity applications or excessive vibration when using magnets.

Inside Wall/Cabinet Mount

- Internal magnets holding unit to wall duct or air handler metal panel.

External Duct Mount

- Cut/drill a 3 inch hole in duct to install and use two self-tapping screws to hold unit to duct.

IMPORTANT!

Install in return air between air filter and cooling coil. For external duct mount, make sure sheet metal sits against gasket surface; the high voltage emitter ends (fiber brushes) must be 2 inches away from other metal and other wiring to prevent grounding/premature failure.

Installation Instructions

1. Disconnect air handler power before installing.
2. Mount the iWave-R after the particle filter and before the indoor coil. This ensures pathogens (i.e., mold) and odors are controlled throughout the entire depth of the coil in addition to the breathing space.
3. The iWave-R is designed with universal mounting- either attach with screws or affix to the system with integral magnets. Mount near the fan inlet (shaft side) on a metal surface in the air handler, internal wall duct or external wall duct depending on what is best for the installation. For external duct mount, a three inch diameter hole will need to be cut/drilled out of the duct. **IMPORTANT:** If mounting on the fan housing, ensure the iWave-R is secured from fan vibration - use short length self-tapping screws so as not to impair operation of fan.

CRITICAL: The iWave-R is designed for flush, external duct mount installations as an optional install. Ensure in all installations that other metal surfaces/wires are kept a minimum of two inches away from the tip ends of the high voltage emitters to prevent grounding, leading to premature failure.

4. The iWave-R has universal voltage capability, connect 24VAC to 240VAC voltage input, whatever is most convenient for quick installation. Although the device only pulls 10 watts, sometimes a dedicated 24VAC power supply may be necessary depending on the current load on the transformer for other system accessories.
 5. Unit may be powered 24/7 or may be interlocked with indoor fan – unit only purifies when air is flowing. If unit is wired with the fan, the quickest air purification to address an air concern is to let the fan/iWave-R run continually for 72 hours. Leaving the fan continually in the 'on' position will provide the best ongoing air purification in the house.
 6. **Wiring:** The iWave-R has a patent-pending universal voltage 24VAC to 240VAC input capability. The black wire (marked 'AC' on label) is for 24VAC to 240VAC voltage input. The white wire (marked 'N' on the label) is the neutral leg for 24VAC or 120VAC; or the other hot leg for 208/240VAC. The green striped wire is ground, marked 'G' on the label. The brown wires (marked 'A' on the label) are leads to a normally closed alarm contact – see step 7.
 7. The iWave-R is equipped with an alarm contact option to provide a visual indicator outside of the air conditioning system to let the homeowner know that it is in normal operation or if there is a fault. The alarm contact, a normally closed contact, rated at 240 VAC/1A, will require a power source and visual indicator, such as a LED. In normal mode, the LED will stay illuminated. If the device goes into default mode, the LED will not light. If a homeowner wants a remote indication of iWave-R status, it is recommend that the 24VAC light (bought separately) be powered through the alarm contacts and sent to a remote wall.
 8. When powered up, a green LED on the iWave-R will illuminate; the ionizer is working and the stepper motor for the cleaning feature is in the home position. If the light is not illuminated, check voltage to the iWave-R. If there is power, the unit has a 240VAC/1A in-line fuse, check the fuse.
 9. **Self-Cleaning/Program Feature:** The patent-pending iWave-R has a self-cleaning feature to ensure it is always operating at peak performance over its design life. The functions for the button include:
 - a. While in normal operation mode, press the button once, the LED light will flash and the stepper motor starts an on-demand cleaning cycle.
 - b. While in cleaning cycle (after step 'a' above), press the button and hold for 3 seconds, it goes into the mode of setting the cleaning cycle intervals. The iWave-R is designed to be programmed for 1, 3, 5, or 10 day cleaning cycle intervals. **The iWave-R is factory preset for cleaning the emitters every third day; this is adequate for most applications and will not need to be reprogrammed in the field.**
- While in the cleaning mode (with LED flashing and cleaning feature working):**
- a. Press the button and hold for 3 seconds, the LED will flash once every second and the motor works once every day.
 - b. Press the button twice (the first press hold for three seconds), the LED will flash twice every second and the motor works once every 3 days. This is the factory preset program.



Installation Instructions Continued

- c. Press the button three times (the first press hold for three seconds), the LED will flash five times every second and the motor works once every 5 days.
- d. Press the button four times (the first press hold for three seconds), the LED will flash ten times every second and the motor works once every 10 days.

The iWave-R remembers the programmed cleaning cycle days. After the power source is removed and applied again, the iWave-R will automatically operate and go back to the previous days.

Note: The iWave-R is designed to be a long term IAQ investment, not requiring ongoing maintenance of replacing expensive parts every year or two like other market approaches. The ion emitters (fiber brushes) used in the iWave-R are designed to where they could easily be replaced after many years in service; in the unlikely event they ever needed to be replaced. Replacement requires a Phillips screwdriver and a few minutes; contact Nu-Calgon for further questions. The iWave-R remembers the programmed cleaning cycle days. After the power source is removed and applied again, the iWave-R will automatically operate and go back to the previous days.

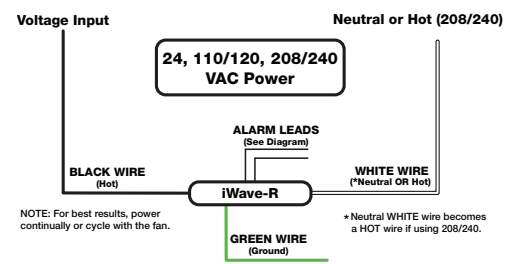
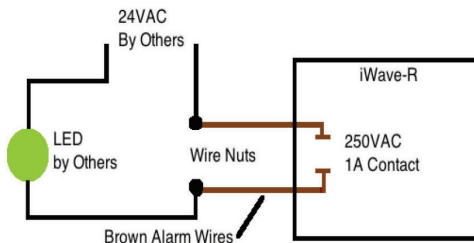
Note: The iWave-R is designed to be a long term IAQ investment, not requiring ongoing maintenance of replacing expensive parts every year or two like other market approaches. The ion emitters (fiber brushes) used in the iWave-R are designed to where they could easily be replaced after many years in service; in the unlikely event they ever needed to be replaced. Replacement requires a Phillips screwdriver and a few minutes; contact Nu-Calgon for further questions.

CRITICAL: Make sure air flows across both brushes at the same time, like a football through a field goal post.

Air Flow Direction



Remote mounted LED will illuminate when the iWave-R is powered and there are no faults. All remote mount wiring, LED, wire nuts and voltage source are provided, mounted and wired by others.



NOTE: For best results, power continually or cycle with the fan.
* Neutral WHITE wire becomes a HOT wire if using 208/240.

iWave®-V

Vortex Air Cleaner

Mounting Options



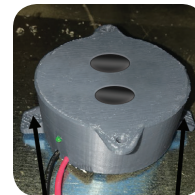
Fan Inlet Mount

- Internal magnets holding unit to fan inlet (shaft side).
- Use self-tapping screws to secure device, especially for high velocity applications or excessive vibration when using magnets.



Inside Wall/Cabinet Mount

- Internal magnets holding unit to metal duct or air handler metal panel.



External Duct Mount

- Use two self-tapping screws to hold unit to duct.
- Drill two 3/8" holes spaced 1-3/4" apart on center or drill one 2-1/4" hole.

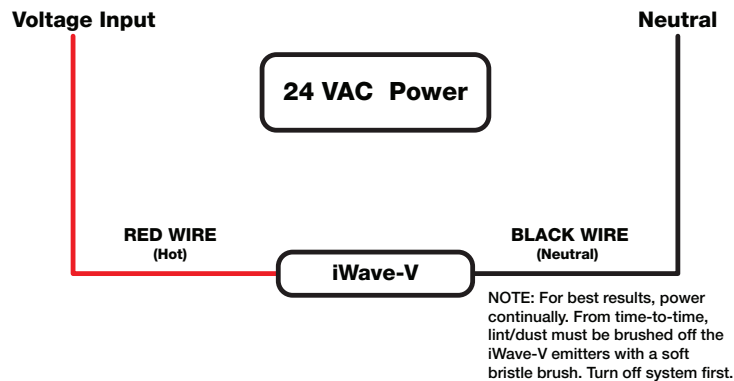
Installation Instructions

1. Disconnect air handler power before installing.
2. Mount unit in one of three ways as shown on the previous page—duct, internal wall or fan inlet.
3. Connect only 24 VAC nominal power—a dedicated power supply may be necessary on some residential systems to prevent excessive power draw on the control board. Check with AHU manufacturer if 10VA capacity is available—WHEN IN DOUBT USE A DEDICATED CIRCUIT!
4. Unit may be powered 24/7 or may be interlocked with fan—unit only delivers plasma and purifies when air is flowing.
5. Red wire goes to 24 VAC, black wire goes to neutral or ground.
6. Green LED will illuminate when powered and there are no faults.
7. Do not touch carbon fiber brushes while powered!

IMPORTANT! Ensure air flows across both brushes at the same time like a football through a field goal post.

8. **CRITICAL!** Ensure all 24 VAC wiring stays away from carbon fiber brushes and is per NEC / local codes. Secure wires if necessary with wire/tape so they never move and touch brushes.
9. **CRITICAL!** Ensure the carbon fiber brushes are at least 2 inches away from anything metal and other wiring!
10. Mount the device after final particle filtration in the system. The best location to mount the device is after the particle filter and before the cooling coil; if this is not possible, after both the particle filter and cooling coil is acceptable on the supply. Mounting the device before the coil will ensure pathogens, mold and odors are controlled throughout the entire depth of the coil.

- Leaving the fan in the “On” position will provide the best air purification results. If the fan cycles based on comfort cooling/heating setpoints, the air quality will not be the best possible.
- Unit has a 250 VAC/1A in-line fuse—if 24 VAC is confirmed and LED is off, check fuse.



Maintenance:

- Turn power off.
- Wipe off the carbon fiber brushes as needed to keep the ion output at maximum levels. Use a cloth or nylon brush to gently clean the brushes when the power is off.
- Brush cleaning intervals will depend on filtration effectiveness upstream of the device and may range from requiring cleaning every filter change to once per year. It is highly recommended to review the brush cleanliness while changing filters.
- There are no parts to replace. Enjoy your new air cleaning system!

iWave®-F & iWave®-M

Flexible Air Cleaner & Mini Flexible Air Cleaner

Installation Instructions:

The iWave-M is a highly versatile ion generating device that is designed to be typically installed at the base of the cooling coil for ductless and duct air conditioning systems; but the device can be installed in supply air as well. The iWave-M is an ideal, no replacement part device that can be integrated into wall or ceiling cassette indoor coils of mini-splits, PTAC units or commercial systems where there may not be enough room to install the iWave-C between the filter and coil. It can also be used to inhibit mold in ice machine applications. The 18 inch ion generating bar can be used for coils up to 36 inches wide. For coils beyond the 18 inch ionizer length, simply center the ionizer bar on the coil to make sure the ionization best covers the coil width. For coils shorter than 18 inches, see the section on iWave-M modification directions on the back page.

Simply peel back the sticky backing to the power pack and ionization bar and stick it across the width of the coil, near its base so the iWave-M treats the coil as well as the breathing zone. For ice machines, install on top and/or side panel of equipment, above the water line so it creates a plasmafield inside the machine. Connect the appropriate leads of the iWave-M to 110VAC to 240VAC power (see diagram on back page) and reassemble the equipment and turn on power to the unit.

Mini-Split Instructions:

- Turn power off to mini-split.
- Open front cover of indoor unit.
- Remove filter screens.
- Measure the length of coil and affix ionizer bar to solid surface (often plastic) on top of the coil. If there is no plastic surface, the iWave-M can be affixed directly to the top of the fins. (See Figure 6.) The width of the plastic region will easily accommodate the iWave-M ionizer bar so it can treat the coil, barrel blower and breathing zone of the room. For coils between 24-36 inches, center the ionizer bar on top of the coil and affix. For coils less than 18 inches, refer to the iWave-M modification directions below. **Note:** Securing the iWave-M with adhesive backed Velcro® strips is another option for easier ongoing removal for other servicing within system.

Critical: Keep any metal from directly touching the emitters.

- Depending on mini-split model, the area available to mount power pack will vary. Either affix with adhesive backing to back cabinet wall or side of coil. (See Figure 6.)
- Run wires to the electrical compartment to hook up to 110VAC to 240VAC incoming power source to where iWave-M will power on continually. For 110/120VAC input, connect the black wire (hot) and white wire (neutral). For 208/240VAC input, connect red wire (hot) and white wire (Neutral or Other AC Phase) to applicable electrical terminal block. Do not use the black wire with 208-240VAC input! **Important:** Always add a wire nut to wire not being used (red or black) depending on voltage input.
- Trim wires to length hook up to appropriate terminal connections and connect. Harness/secure wires within the equipment as necessary. The LED on iWave-M power pack will turn green when power is supplied.
- Reassemble filter screens, close the front cover and turn on power to mini-split.

iWave-M Modification Instructions:

For typical minisplit (or ice machine) applications, no adjustment in iWave-M length is necessary. For an irregular application where the iWave-M is too long for the coil which it's being applied, perform the following steps:

1. Measure how much past the end of the coil the iWave-M lies.
2. Bend the iWave-M back on top of itself (DO NOT bend under with sticky backing facing each other) so the brush pairs on the top will lay next to the brush pairs on the bottom, shown in Figure 1.
3. Peel the backing off of the iWave-M and press it down to the cooling coil starting at the power entry side of the iWave-M. DO NOT press down on the end of the iWave-M that will need folded to shorten the length, see Figure 2. **Note:** Securing the ionization bar with an adhesive backed Velcro® strips is another option for easier removal with equipment service.
4. Fold the iWave-M back to achieve the length required, lining up the bottom and top layer brush pairs as shown in Figure 1, and place a piece of electrical tape across the joint. See Figure 3.
5. Continue to use electrical tape down the iWave-M towards the end, making sure that the tape joints are between the brush pairs. DO NOT allow the tape to cover the brush pairs. See Figure 4.
6. DO NOT crease the end of the iWave-M flat. As a guide, use a #2 Phillips screwdriver inside the fold joint to ensure the proper bend is achieved. See Figure 5.
7. Once the iWave-M has been folded and taped to the length required, push it down on the coil.
8. A successful fold procedure will create “pockets” for the carbon fiber brushes to emit the ions.



Figure 1

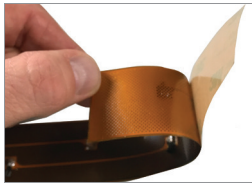


Figure 2



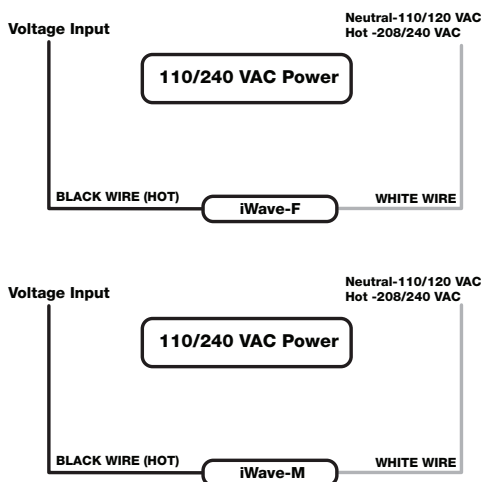
Figure 3



Figure 4

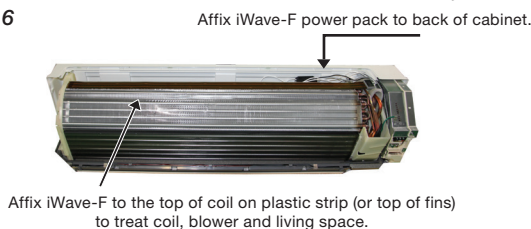


Figure 5



Typical Location Install on Ductless Wall System:

Figure 6



Cleaning: If required, use a wet wipe or damp cloth to clean the ionizer bar. A soft bristle brush, like toothbrush, can also be used to clean debris from ion emitters. Do not expose the iWave-F to corrosive cleaners. Contact Nu-Calgon for further guidance with coil cleaner options.

iWave-F Modification Instructions:

When the iWave-F is too long for the coil which it's being applied, perform the following steps:

1. Measure how much past the end of the coil the iWave-F lies.
2. Bend the iWave-F back on top of itself (DO NOT bend under with sticky backing facing each other) so the brush pairs on the top will lay next to the brush pairs on the bottom, shown in Figure 1.
3. Peel the backing off of the iWave-F and press it down to the cooling coil starting at the power entry side of the iWave-F. DO NOT press down on the end of the iWave-F that will need folded to shorten the length. See Figure 2.
4. Fold the iWave-F back to achieve the length required, lining up the bottom and top layer brush pairs as shown in Figure 1, and place a piece of electrical tape across the joint. See Figure 3.
5. Continue to use electrical tape down the iWave-F towards the end, making sure that the tape joints are between the brush pairs. DO NOT allow the tape to cover the brush pairs. See Figure 4.
6. DO NOT crease the end of the iWave-F flat. As a guide, use a #2 Phillips screwdriver inside the fold joint to ensure the proper bend is achieved. See Figure 5.
7. Once the iWave-F has been folded and taped to the length required, push it down on the coil.
8. A successful fold procedure will create “pockets” for the carbon fiber brushes to emit the ions.



Troubleshooting:

<u>Problem</u>	<u>Solution</u>
Unit won't power up	Confirm proper voltage is applied and to the correct terminal
Display shows "FALT"	Remove power, wait one minute and reapply power. If "FALT" still appears, try using alternate power source, i.e. low voltage input versus high voltage input or vice versa. If FALT still shows, call Nu-Calgon.
No Display / LED	If the correct voltage source has been confirmed and the unit does not power up contact Nu-Calgon.

WARNING

1. The health aspects associated with the use of this product and its ability to aid in disinfection of environmental air have not been investigated by UL LLC.
2. This product shall not be installed behind a suspended floor/ceiling or a structural wall, ceiling, or floor.
3. This product is suitable for mounting to duct of metallic Construction only. Installation must be such that the structural integrity of the ducting is not compromised.
4. RISK OF ELECTRIC SHOCK. CAN CAUSE INJURY OR DEATH: DISCONNECT ALL ELECTRIC POWER SUPPLIES BEFORE SERVICING

Three-Year Limited Warranty:

The iWave-C offers a limited warranty for three years that covers any defects in material or workmanship under normal use. If you make a claim during the warranty period, you must provide proof of purchase and proof of proper installation by a licensed contractor for the warranty to be valid. The iWave warranty does not cover labor, return shipping charges, damage from improper installation or improper voltage usage. The iWave warranty begins on the date that the unit was purchased. Installation of your iWave by any person other than a licensed contractor will void the warranty. Contact your local Nu-Calgon account manager or info@nucalgon.com with further questions.

iWave®-C

Commercial Air Cleaner

Installation Instructions:

The iWave-C is designed for metal duct mounting applications. The preferred mounting location is after a prefilter and before the cooling coil. An alternate mounting location is the supply air duct or the return air duct. The weatherproof housing will allow mounting indoor or outdoor.

Step 1. Turn power off to the unit.

Step 2. After finding the appropriate location, cut or drill a 4 inch (100mm) round hole. Insert the unit into the 4 inch (100mm) round hole and secure with four self tapping screws provided. Please note, if the unit is being mounted to duct board, the included spring loaded wing nuts and bolts will be required.

Wiring:

Confirm power is off prior to wiring. Follow all local and national electric, mechanical and building codes when in-stalling and wiring. The iWave-C can be powered with a 24VAC low voltage circuit or 110VAC to 240VAC high voltage circuit. The face panel of the unit is labeled showing which terminals are 24VAC, 110-240VAC input and neutral and come prewired from the factory. Opening the unit is not necessary for installation. The unit is provided with 6 feet of liquid-tight flex conduit to reach a junction box for wiring.

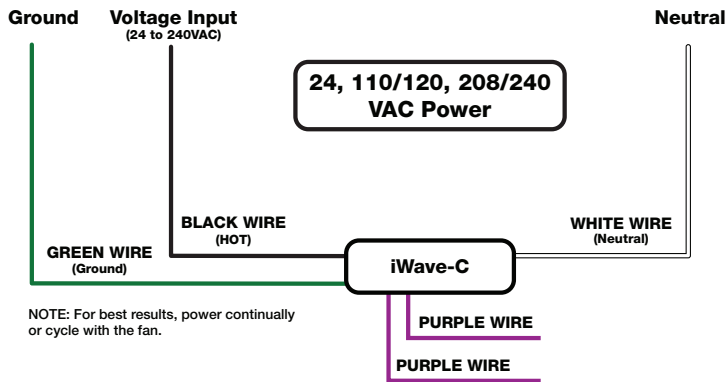
The wires are color coded as follows:

- Black wire = 24-240VAC input
- White wire = Neutral
- Green wire = Ground
- Purple wires = Alarm Dry Contact

The unit is provided with alarm contacts for use with a building management system. When the unit is powered and there are no faults, the alarm “dry” contacts will be closed, providing continuity. The contacts are rated up to 250VAC at 1A.

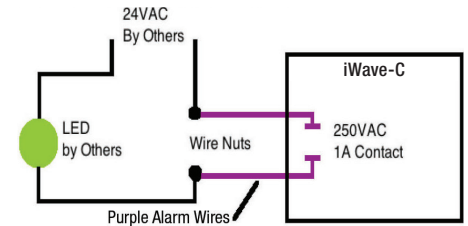
CAUTION! NEVER TOUCH BRUSHES WHILE OPERATING. SHOCK MAY OCCUR. DO NOT CONNECT WITH AN EXTENSION CORD.

Maintenance:



ALARM RELAY WIRING EXAMPLE

Remote mounted LED will illuminate when the iWave-C is powered and there are no faults. All remote mount wiring, LED, wire nuts and voltage source are provided, mounted and wired by others.



The iWave-C is designed to be maintenance free for years of trouble-free operation with the patent pending self-cleaning system; eliminating the need to replace expensive UV lights/cells every couple of years as with competing technologies. Although extensively tested for durability, it's possible over years of self-cleaning cycles, the carbon fiber brushes can wear from friction and require replacement. With the unit powered off, remove the iWave-C from the duct. Remove the two Phillips screws that fasten the brushes to the iWave-C. Pull the brushes out of the electrical connector and insert new brushes (available through Nu-Calgon). Replace the Phillips screws and attach the iWave-C into the duct and re-energize the device to initiate normal operation.

