

Installer's Guide

60 HZ Convertible Air Handlers 1-1/2 – 3 Ton

Black Epoxy Coil
GAF2A0A18S11EE
GAF2A0A24S21EE
GAF2A0A30S21EE
GAF2A0A36S31EE

Standard Coil
GAF2A0A18S11SE
GAF2A0A24S21SE
GAF2A0A30S21SE
GAF2A0A36S31SE

ALL phases of this installation must comply with NATIONAL, STATE AND LOCAL CODES

Important: This Document is customer property and is to remain with this unit. Please return to service information pack upon completion of work.

Important: These instructions do not cover all variations in systems nor provide for every possible contingency to be met in connection with the installation. Should further information be desired or should particular problems arise which are not covered sufficiently for the purchaser's purposes, the matter should be referred to your installing dealer or local distributor.

Note: The manufacturer recommends installing ONLY AHRI approved, matched indoor and outdoor systems. Some of the benefits of installing approved matched indoor and outdoor split systems are maximum efficiency, optimum performance, and the best overall system reliability.

Note: All AHRI ratings use a 90 second fan off delay. Use your branded thermostat or separate relay to enable this delay.

Note: Condensation may occur on the surface of the air handler when installed in an unconditioned space. When units are installed in unconditioned spaces, verify that all electrical and refrigerant line penetrations on the air handler are sealed completely.

Important: The GAF2 air handlers will only use the following internal electric heaters:
 BAYECAA05LG1, BAYECAA08LG1, BAYECAA10LG1

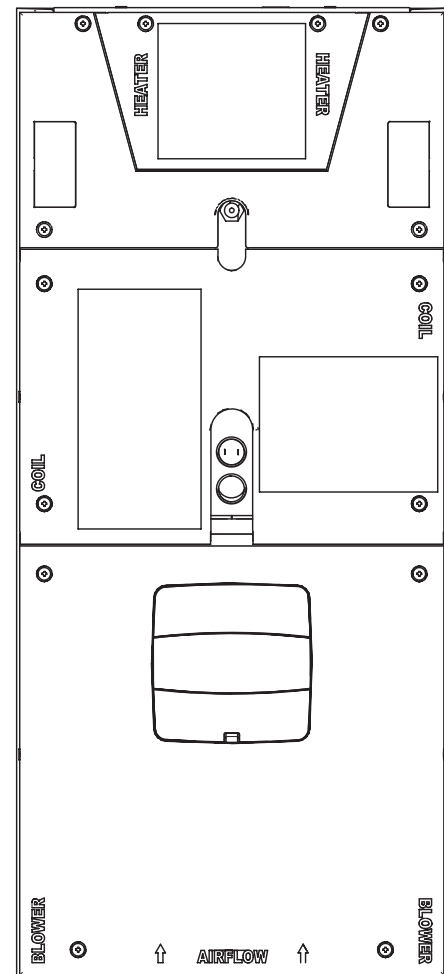

Table of Contents

Section 1. Safety Information.....	2
Section 2. Unit Design.....	3
Section 3. Unit Preparation.....	5
Section 4. Optional Cabinet Disassembly.....	6
Section 5. Place Unit at Location.....	9
Section 6. Unit Location Considerations.....	10
Section 7. Setting the Unit – Vertical Installation.....	15
Section 8. Setting the Unit – Horizontal Installation.....	16
Section 9. Connecting the Duct work.....	17
Section 10. Refrigerant Line.....	18
Section 11. Refrigerant Line Brazing.....	19
Section 12. Condensate Drain Piping.....	22
Section 13. Electrical – Low Voltage.....	24
Section 14. Electrical – High Voltage.....	26
Section 15. Filters.....	28
Section 16. Unit Outline Drawing.....	29
Section 17. Start Up.....	30
Section 18. Sequence of Operation.....	31
Section 19. Checkout Procedures.....	31

Section 1. Safety Information

⚠ WARNING

SAFETY HAZARD! This information is intended for use by individuals possessing adequate backgrounds of electrical and mechanical experience. Any attempt to repair a central air conditioning product may result in personal injury and/or property damage. The manufacturer or seller cannot be responsible for the interpretation of this information, nor can it assume any liability in connection with its use.

⚠ WARNING

LIVE ELECTRICAL COMPONENTS! During installation, testing, servicing, and troubleshooting of this product, it may be necessary to work with live electrical components. Failure to follow all electrical safety precautions when exposed to live electrical components could result in death or serious injury.

⚠ CAUTION

HAZARDOUS VAPORS! Do not install an air handler with a non-ducted return in the same closet, alcove, or utility room as a fossil fuel device. Hazardous vapors can be distributed throughout the conditioned space and equipment damage can result.

⚠ CAUTION

CORROSION HAZARD! To prevent shortening its service life, the air handler should not be used during the finishing phases of construction. The low return air temperatures can lead to the formation of condensate. Condensate in the presence of chlorides and fluorides from paint, varnish, stains, adhesives, cleaning compounds, and cement creates a corrosive condition which may cause rapid deterioration of the cabinet and internal components.

⚠ CAUTION

SAFETY HAZARD! Sharp Edge Hazard. Be careful of sharp edges on equipment or any cuts made on sheet metal while installing or servicing. Personal injury may result.

Important: Panel damage can occur with prolonged exposure to POE lubricants. Air handler front panels that come in contact with POE oil must be washed immediately with soapy water.

⚠ WARNING

This product can expose you to chemicals including lead, which are known to the State of California to cause cancer and birth defects or other reproductive harm. For more information go to www.P65Warnings.ca.gov

Note: Representative illustrations only included in this document. Most illustrations display the upflow configuration.

Section 2. Unit Design

2.1 Cabinet Penetration

Important: Due to the unique design of this unit, which allows the electrical wiring to be routed within the insulation, do not screw, cut, or otherwise puncture the unit cabinet in any location other than the ones illustrated.

Important: Under no conditions should metal strapping be attached to the unit to be used as support mechanisms for carrying or suspension purposes.

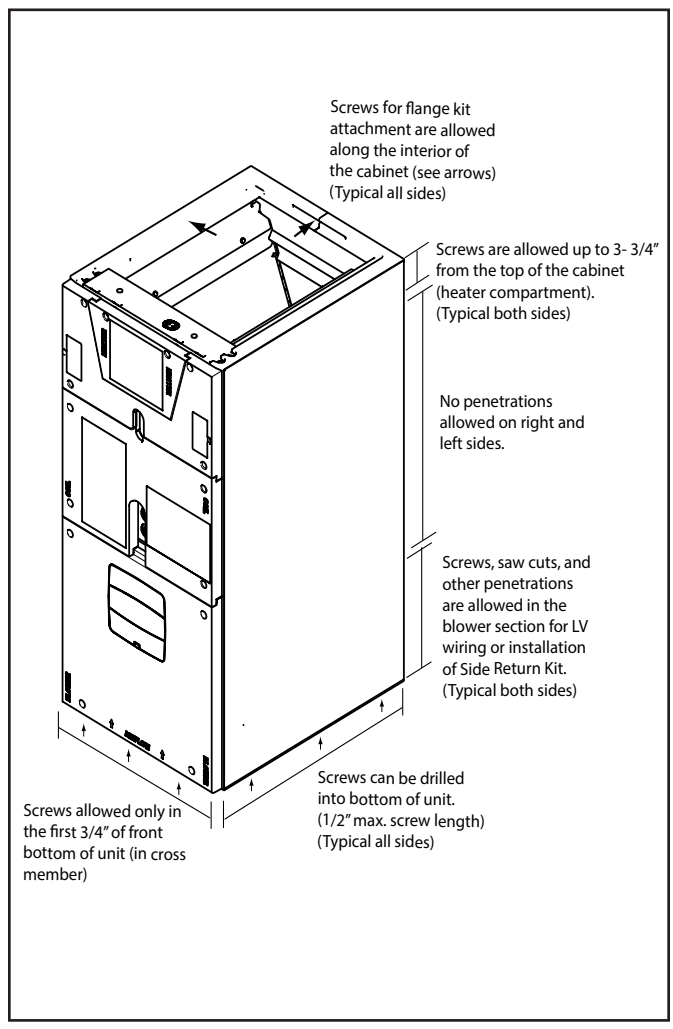

2.2 Panel Removal

The unit contains four (4) access panels: Blower, Coil, Line Set, and Heater.

The Blower, Coil, Line Set, and Heater panels are removed using a Phillips head screwdriver.

NOTE: The Blower, Coil and Heater panels must be removed prior to removing the Line Set panel.

NOTE: The Coil Panel should be removed before the other panels.

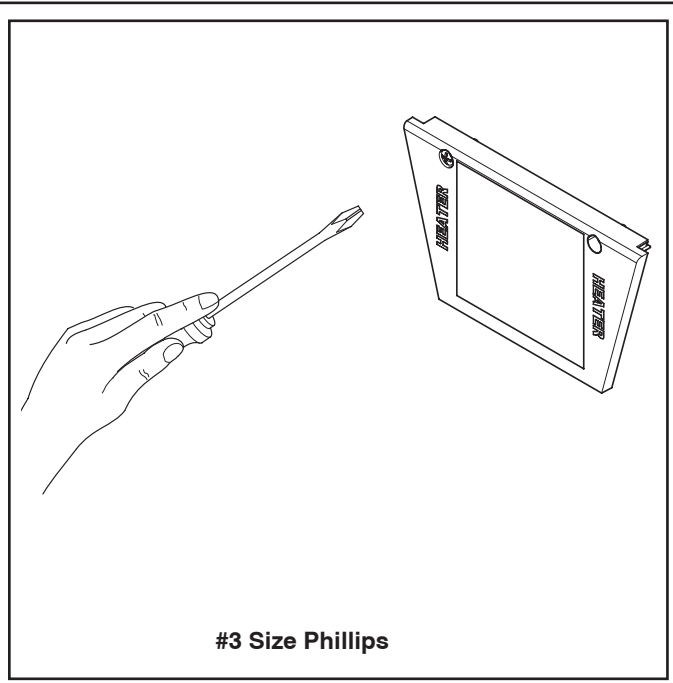

To remove Coil Panel:

1. Use a screwdriver to remove the four screws on Coil Panel.
2. Pull panel straight out, away from cabinet.
3. Set aside.

To remove Blower Panel:

1. Use a screwdriver to remove the two screws on Blower Panel.
2. Pull top of panel out, away from cabinet.
3. Pull panel upward and out of channel.
4. Set aside.

To remove Heater Panel:

1. Use a screwdriver to remove the two screws on Heater Panel.
2. Pull top of panel out, away from cabinet.
3. Pull panel upward and out of channel.
4. Set aside.

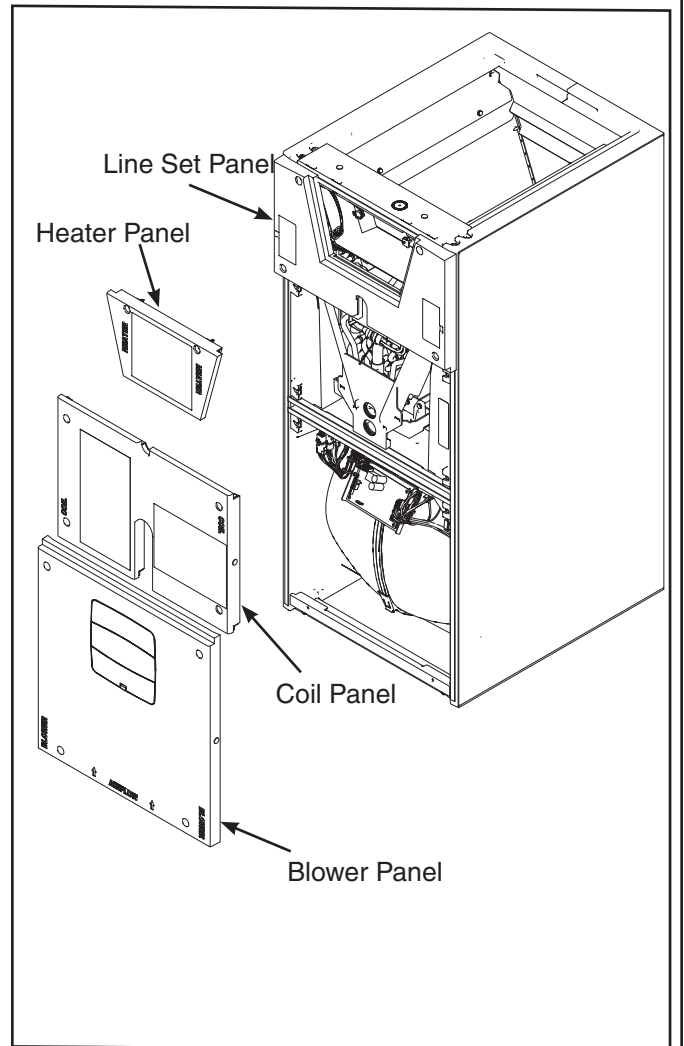

IMPORTANT: Removal of the Line Set Panel is required for all refrigerant line brazing and some condensate line assembly depending on your orientation.

To remove Line Set panel:

1. Remove both Heater and Coil panels.
2. Use a screwdriver to remove the four screws on Line Set Panel.
2. Pull panel straight out, away from cabinet.
3. Set aside.

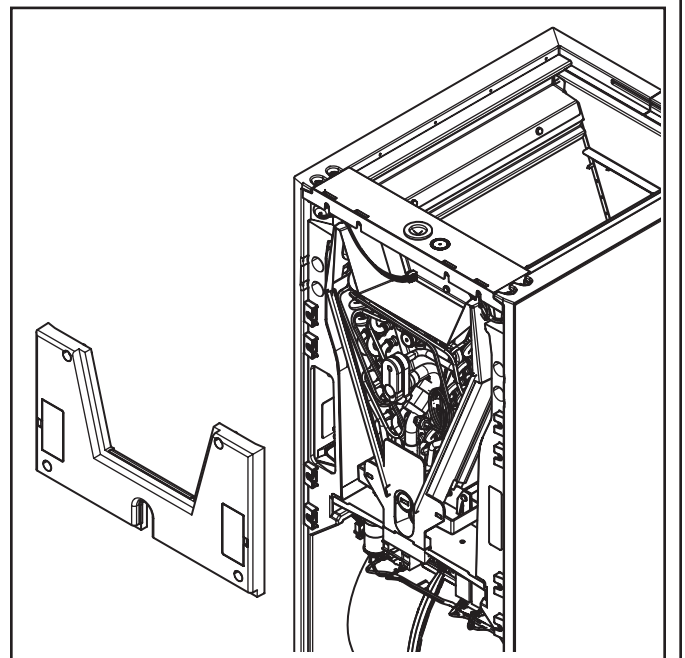

Section 3. Unit Preparation

3.1 Prepare The Unit For Installation

STEP 1 - Check for damage and report promptly to the carrier any damage found to the unit.

Note: If the unit must be transported in a horizontal position, it must be laid on its back (marked "REAR" on carton).

Note: Remove the cardboard from the bottom of the blower. Cut the tie wrap and remove the foam block located at the motor.

Note: After the unit is removed from the carton, release pressure from the coil to verify coil is pressurized and leak free.

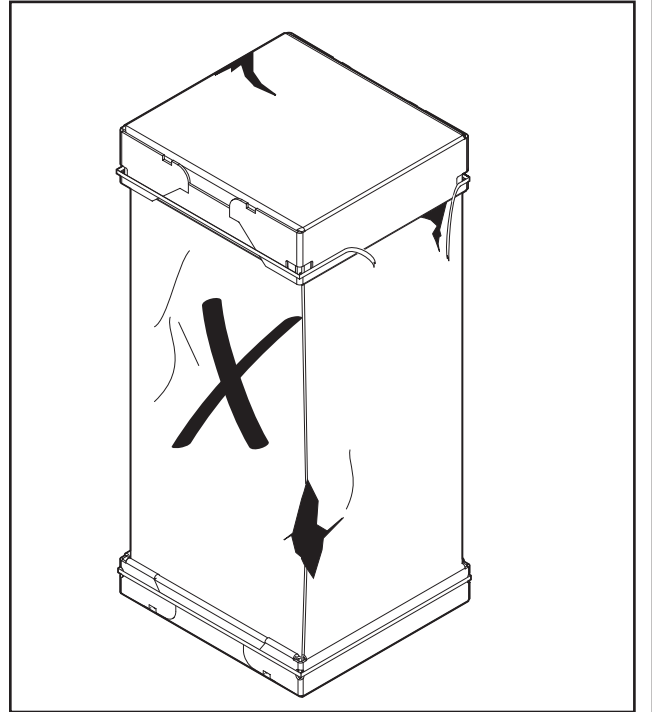

3.2 Unit Accessories

Table 3.1

Accessory Number	Description	Fits Cabinet Size ①
BAYECAA05LG1	Electric Heater, 5kW, Lugs, 24V Control, 1 Ph	A1
BAYECAA08LG1	Electric Heater, 8kW, Lugs, 24V Control, 1 Ph	A1
BAYECAA10LG1	Electric Heater, 10kW, Lugs, 24V Control, 1 Ph	A1
BAYSFSCABAA	Supply Duct Flange A1 ①	A1
BAYRETFLGAA	Return Duct Flange A	A1
TASB175SB	Plenum Stand with Sound Baffle A	A1
BAYFRKIT100	Front Return Kit	A1
BAYBRFBX100	Bottom Return Filter Box	A1
BAYWMKIT001	Wall Mount Kit	A1
BAYLVKIT100A	Low Voltage Conduit Entry Kit	A1
BAYECPDKIT1A	Pull Disconnect Kit	A1
BAYAHTXV1836	R-22 TXV Conversion Kit	A1
BAYCNDPIP01A	3/4" PVC Threaded Pipe Kit foam seal (10 per box)	A1

① GAF2A0A18-36 Cabinet is one piece 17.5" wide

Section 4. Optional Cabinet Disassembly

4.1 Disassemble cabinet for installation in tight areas or as needed.

Note: If the unit must be transported in a horizontal position, it must be laid on its back (marked "REAR" on carton).

Note: To reassemble cabinet, follow the steps in reverse order. Ensure electrical connections are secure and the plug clips are engaged.

STEP 1 - Remove all four front panels. See Section 2.2.

STEP 2 - Disconnect the high and low voltage connectors on the blower. There is a seal plate that slides over the control panel lip. This panel will be loose once the blower is removed.

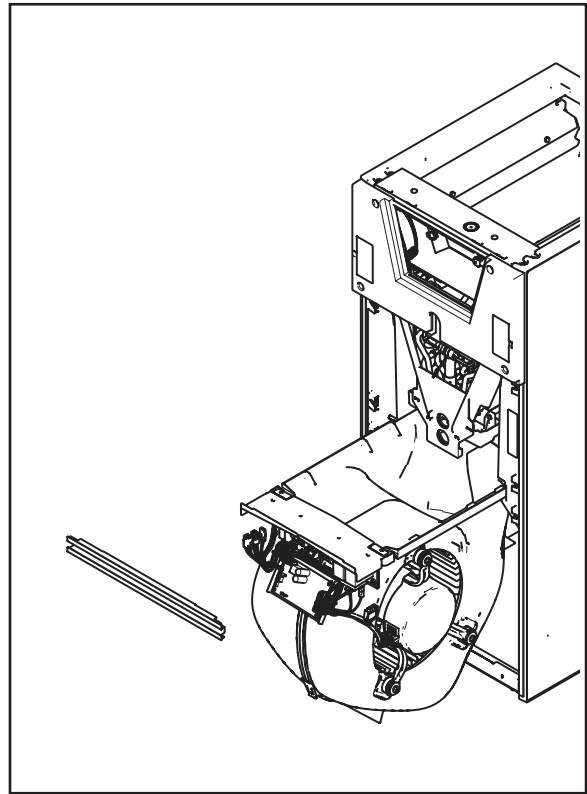

STEP 3 - Slide Blower assembly out of unit using built-in blower support channels and set aside.

Note: Remove the cardboard from the bottom of the blower. Cut the tie wrap and remove the foam block located at the motor.

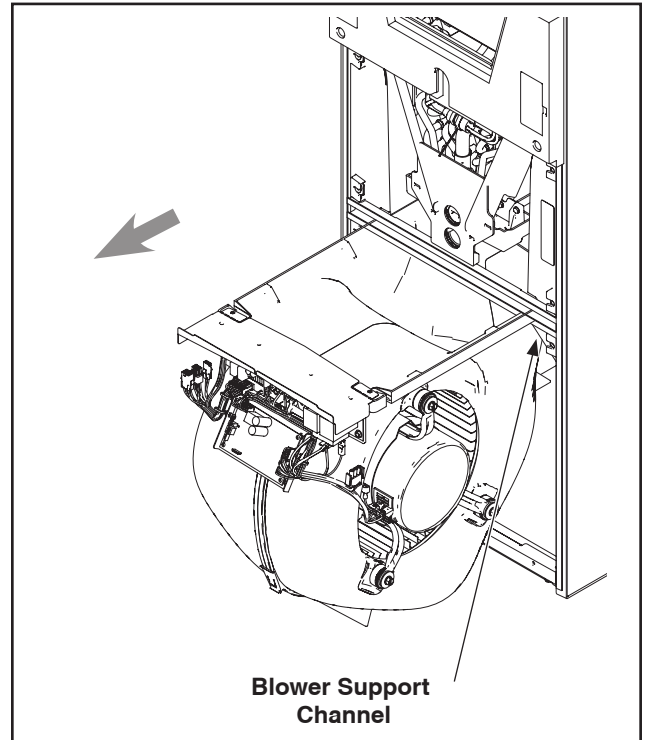

STEP 4 - Slide the Coil assembly out of unit using built-in coil support channels and set aside.

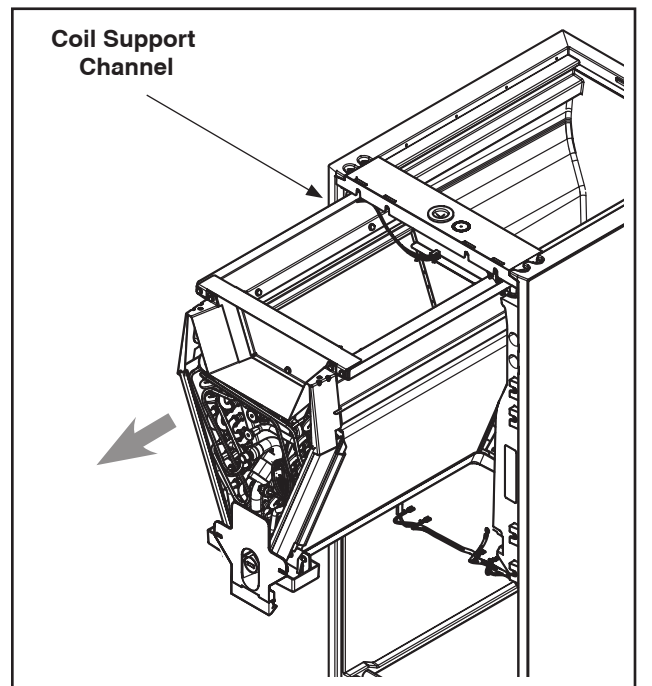

STEP 5 - For extremely tight spaces where the cabinet needs to be rotated through a small opening, remove the top panel and all cross members. Use a manual driver to avoid stripping screw holes.

Note: Cross Members are removed by rotating them toward the door opening and then lifting up and out of the unit.

Note - When carrying the air handler to the install location, be sure to use approved carrying procedures shown in Section 5, if needed.

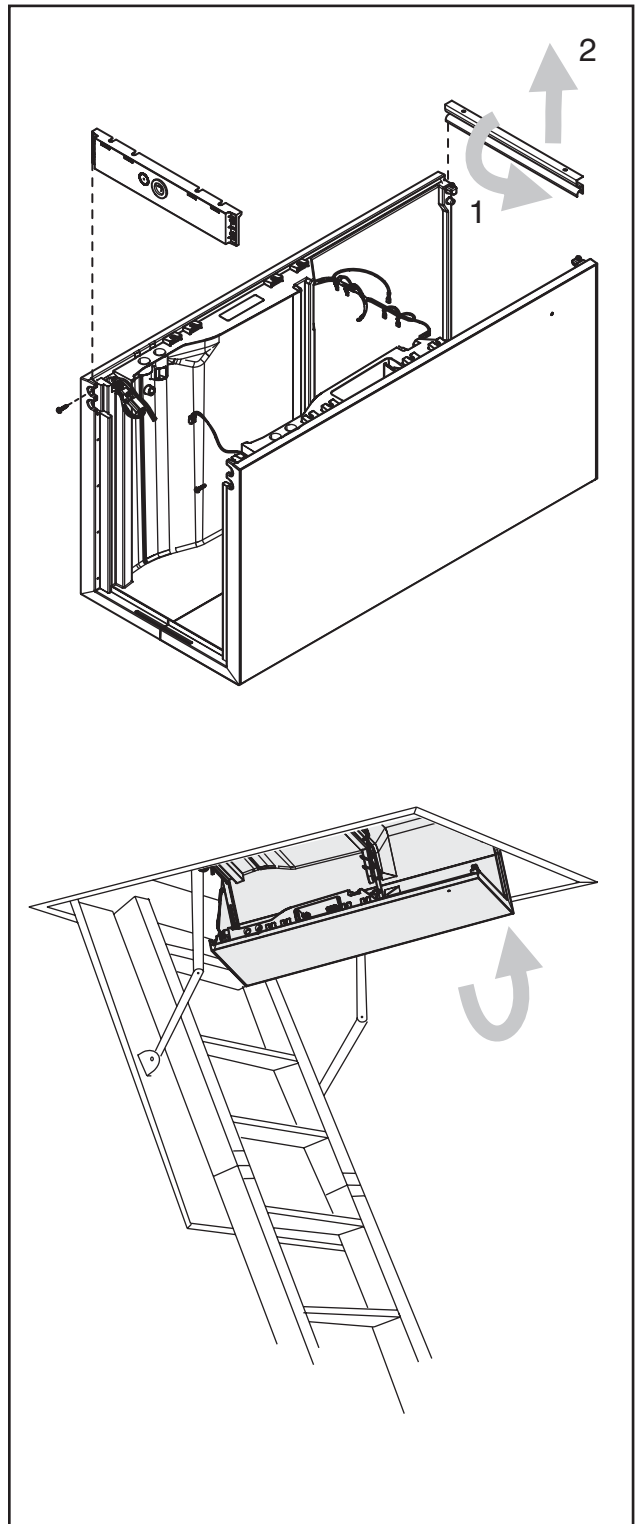

Section 5. Place Unit at Location

5.1 Carry Unit

STEP 1 - Carry the unit to the installation location.

STEP 2 - Reassemble by reversing the steps listed in Section 4 if disassembly was required.

Important: Under no conditions should metal strapping be attached to the unit to be used as support mechanisms for carrying or suspension purposes.

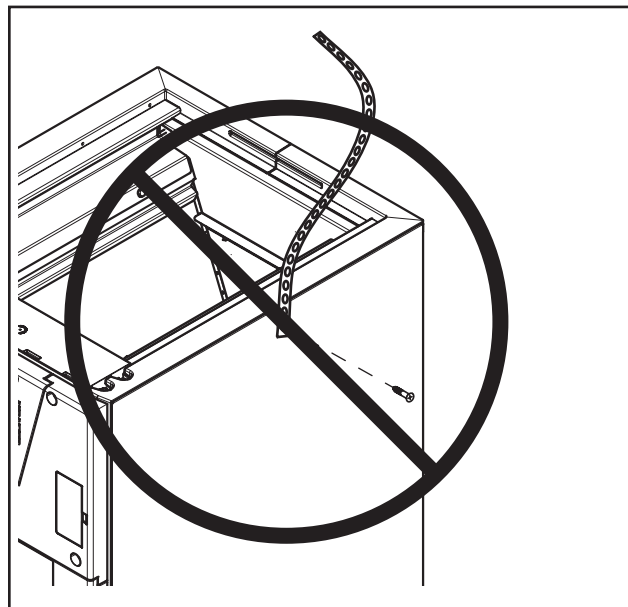

Approved carrying:

1. Hold by the cross members within the cabinet or unit top plate and use as handles for lifting and carrying the coil and blower sections.

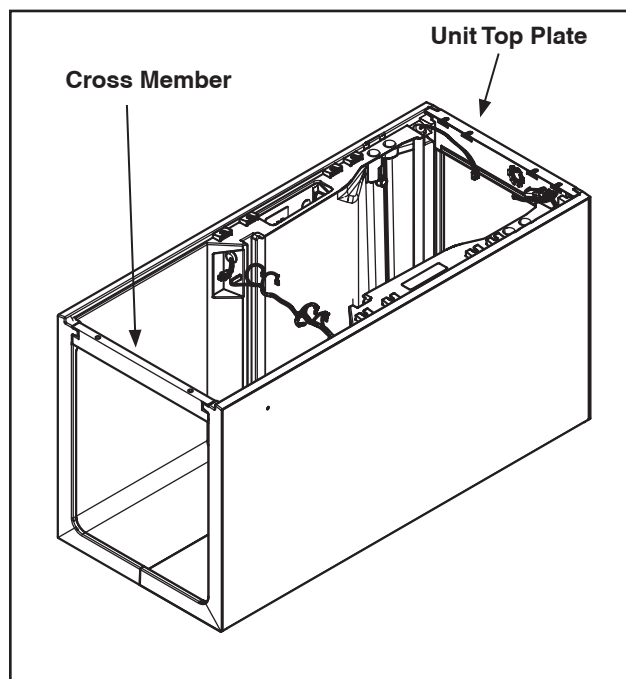

Section 6. Unit Location Considerations

6.1 Unit Dimensions and Weight

Table 7.1

Model Number	H x D x W in.	Unit Net Weight lbs.
GAF2A0A18S11EE GAF2A0A18S11SE	39 x 22 x 17.5	107
GAF2A0A24S21EE GAF2A0A24S21SE	39 x 22 x 17.5	110
GAF2A0A30S21EE GAF2A0A30S21SE	39 x 22 x 17.5	111
GAF2A0A36S31EE GAF2A0A36S31SE	39 x 22 x 17.5	112

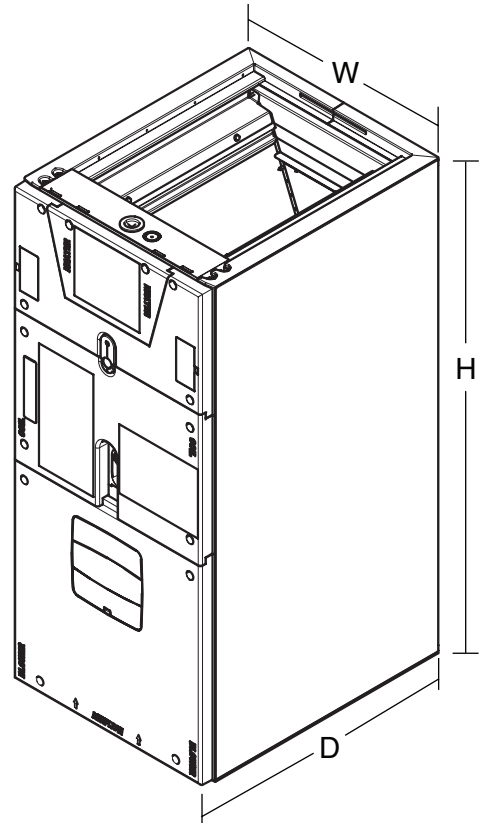

6.2 Three-Way Conversion

To place the unit in the configuration your application requires (upflow, horizontal right, or horizontal left), simply turn the unit to that orientation.

Note: The air handlers are shipped from the factory suitable for three-way application.

Note: Entry for low voltage connections is allowed on either side of cabinet.

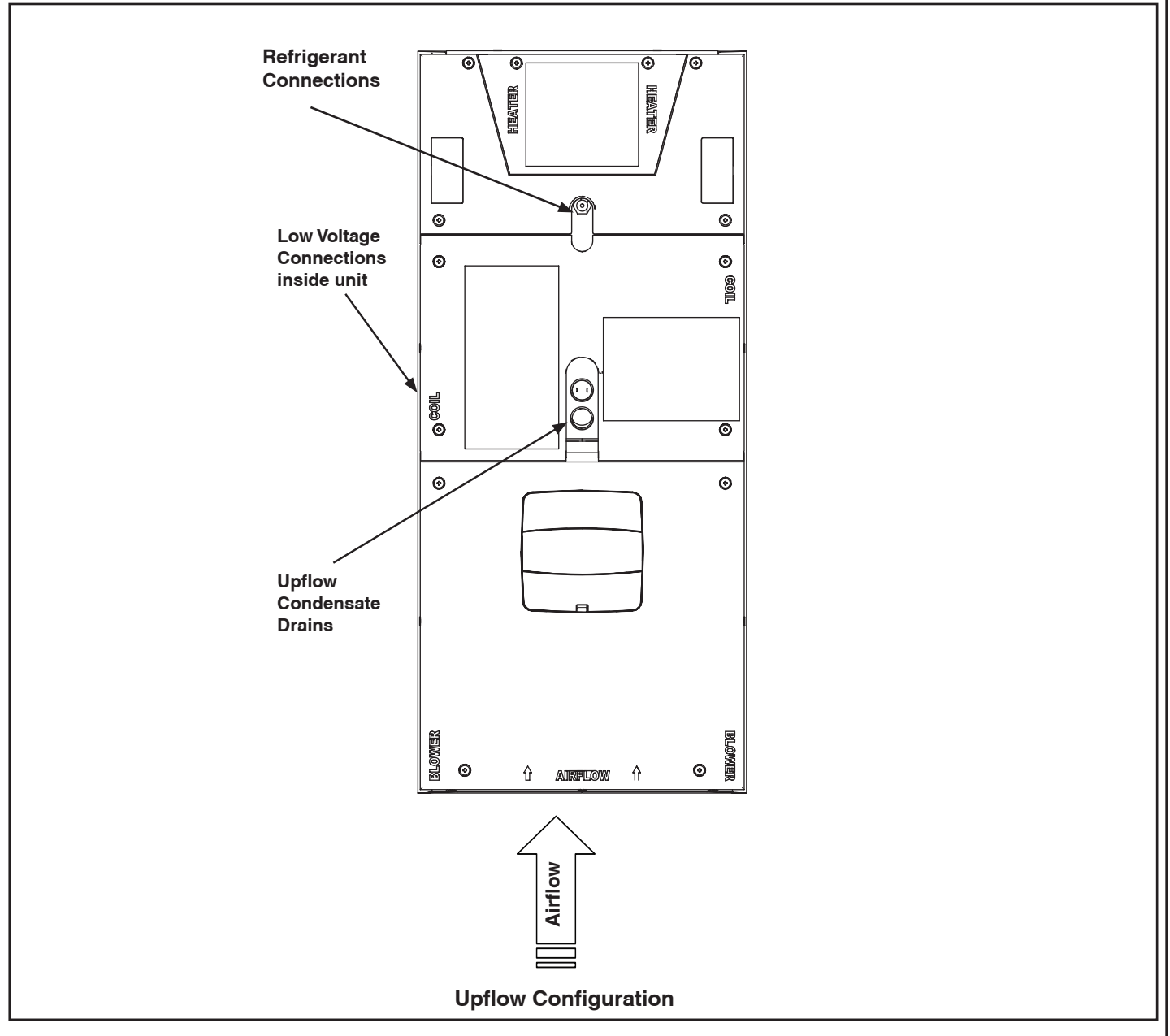

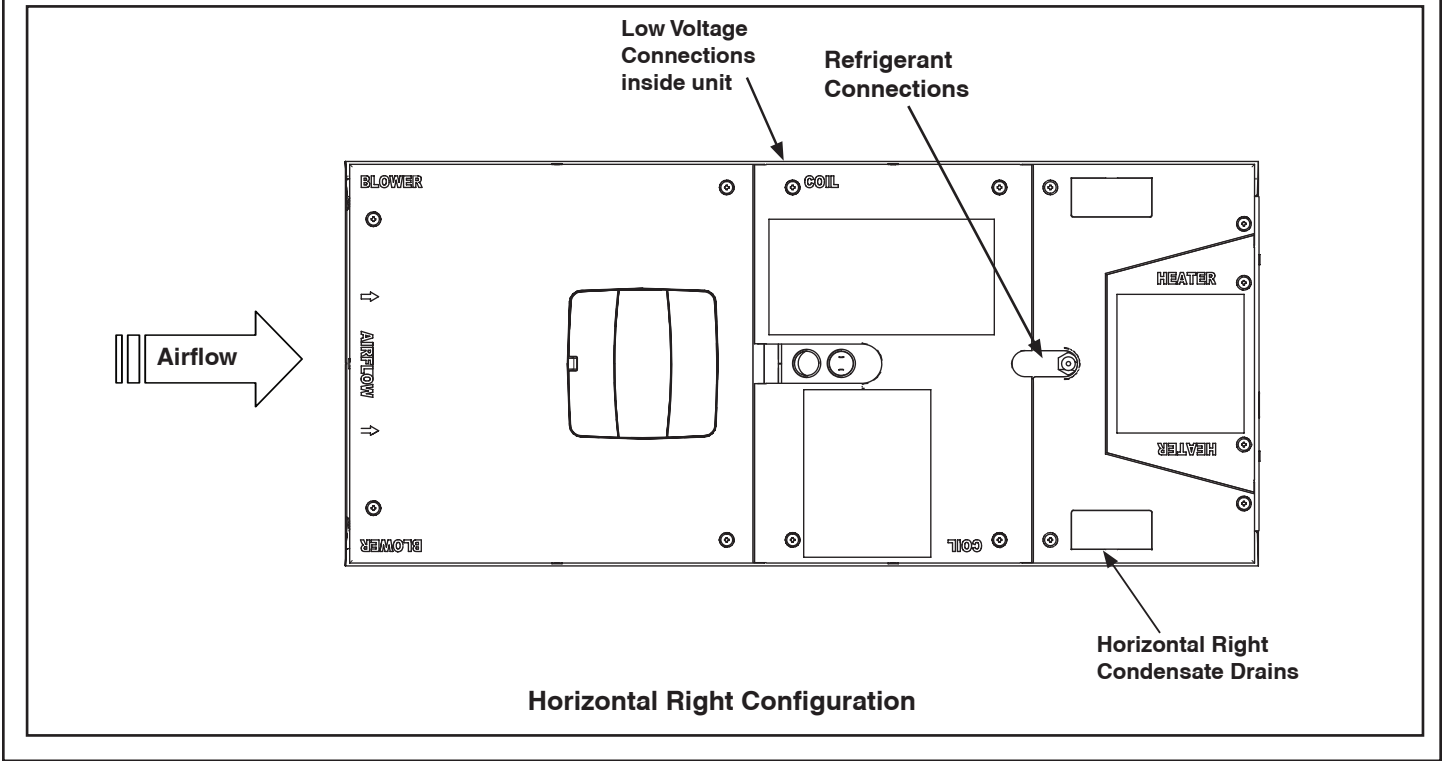
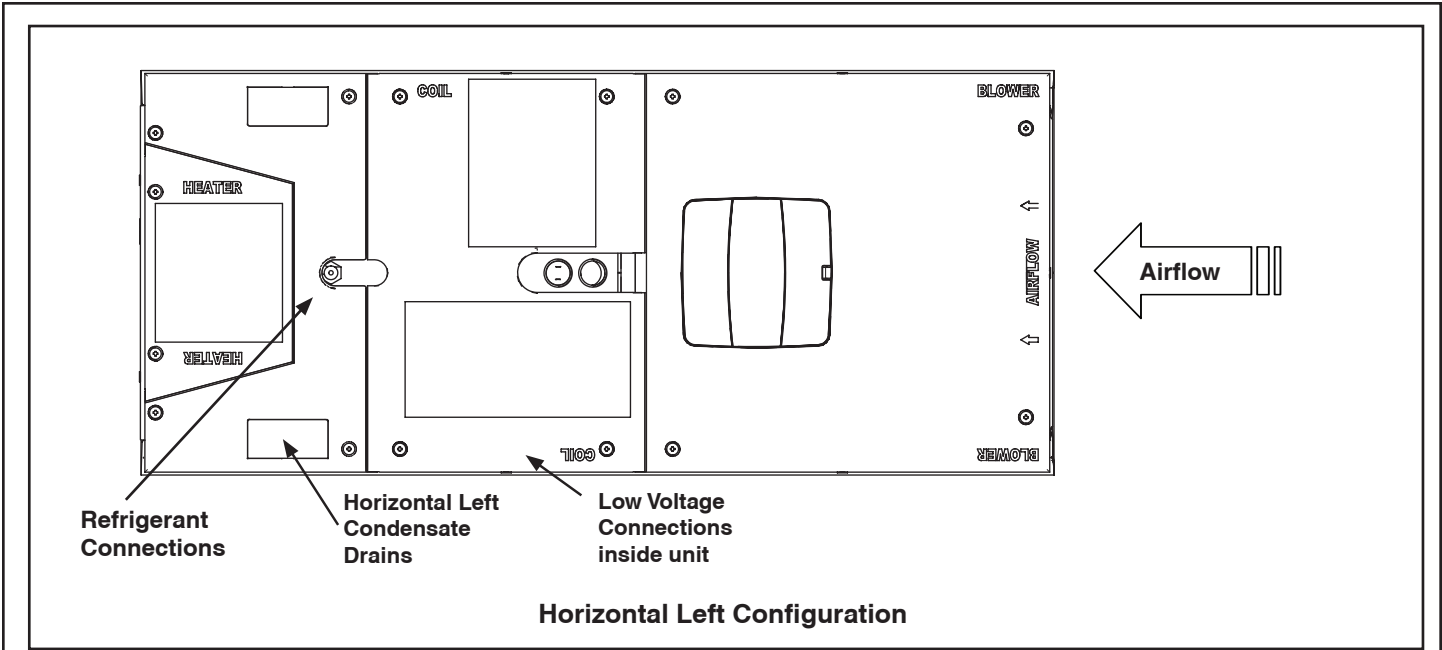

6.3 Minimum Clearance Table

Minimum Unit Clearance Table		
	To Combustible Material (Required)	Service Clearance (Recommended)
Sides	0"	2"
Front	0"	21"
Back	0"	0"
Inlet Duct	0"	N/A
Outlet Duct	0"	N/A

6.4 Non Ducted Applications

⚠ CAUTION

HAZARDOUS VAPORS! Do not install an air handler with a non-ducted return in the same closet, alcove, or utility room as a fossil fuel device. Hazardous vapors can be distributed throughout the conditioned space and equipment damage can result.

Non-Ducted Return Installations:

- Installation in a closet, an alcove, or a utility room without a return duct requires the use of a plenum accessory kit as it uses the area space as a return air plenum. Minimum clearances to combustible materials and service access must be observed (see outline drawing).
- This area may also be used for other purposes, including an electric hot water heater, but in no case shall a fossil fuel device be installed and/or operated in the same closet, alcove, or utility room.
- Review local codes to determine limitations if the unit is installed without a return air duct.

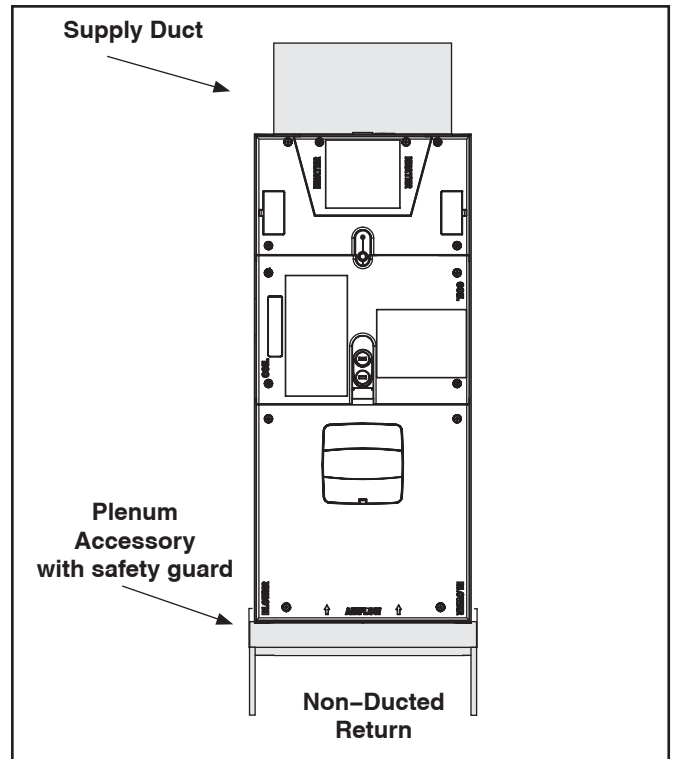

6.5 Ducted Applications

Ducted Return Installations:

- Installation in an attic, garage, or crawl space with ducted supply and return air is appropriate. Minimum clearances to combustible materials and service access must be observed (see outline drawing).

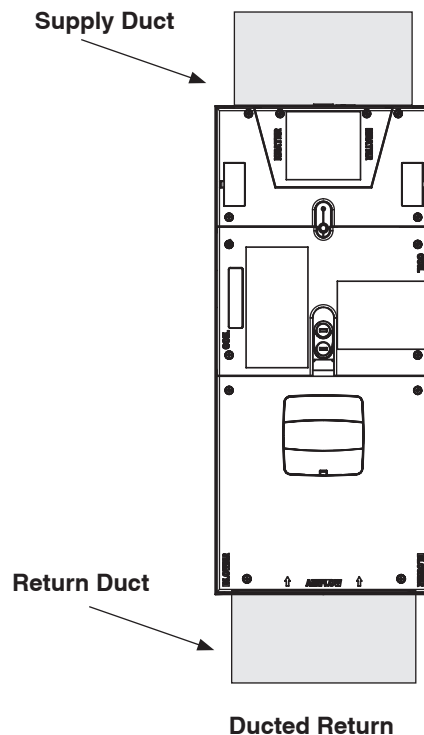

6.6 Additional Unit Preparation Considerations

For proper installation the following items must be considered prior to moving the unit to its installation site:

- **Important:** *When the air handler is located adjacent to the living area, the system should be carefully designed with returns which minimize noise transmission through the return air grill. Although the air handler is designed with large blowers operating at moderate speeds, any blower moving a high volume of air will produce audible noise which could be objectionable when the unit is located very close to a living area. It is often advisable to route the return ducts under the floor or through the attic. Such design permits the installation of air return remote from the living area (i.e. central hall).*
- Pursuant to Florida Building Code 13-610.2.A.2.1, this unit meets the criteria for a factory sealed air handler.
- If a side return is needed for your application, the side return MUST be installed prior to moving the air handler to its installation location. Unless two side returns are used, the Side Return Kit may not be on the same side as the LV wiring entry point. See the Side Return Kit # BAYSRKIT100A Installer Guide for detailed instructions, if used.
- Study the unit's outline drawing and dimensions prior to selecting the installation site. Note in advance which electrical conduit entry points and condensate drain holes are to be used, so that proper clearance allowances can be made for installation and future maintenance.
- Installation of the air handler must be made prior to, or at the same time as, the installation of the outdoor unit in order to allow access for refrigerant lines.
- Consider the overall space needed when external accessories are used, additional height and width requirements may exist.
- These units are not approved for outdoor installation.
- These units must be installed in the proper air flow direction.
- Any third-party heater accessories, including hydronic coils and duct heaters must be downstream of the unit.
- Note: No atomizing style humidifier is allowed in the return plenum with the use of this unit.
- Excessive bypass air may cause water blow-off, which will adversely affect system operation and air cleaner performance. To verify bypass airflow, follow the Bypass Humidifier Pre-Installation Checkout and Set-Up Procedures available through your local distributor. Ask for publication number 18-CH37D1-* Steam and Flow-through Fan Power Duct-mounted Humidifiers. Follow the humidifier installation instructions. These should only be installed on the supply air side of the system.
- **Note:** *The air handlers have been evaluated in accordance with the Code of Federal Regulations, Chapter XX, Part 3280 or the equivalent. "SUITABLE FOR MOBILE HOME USE."*
- **Note:** ***This unit is certified to UL 1995. The interior cabinet wall meets the following:***
 - UL94-5VA Flame Class Listed
 - UL723 Steiner Tunnel Listed for 25/50 Flame/Smoke
 - UL746C Listed for Exposure to Ultraviolet Light, Water Exposure and Immersion

Section 7. Setting the Unit – Vertical Installation

7.1 Considerations

Provide a minimum height of 14 inches for proper unrestricted airflow below the unit. Allow a minimum of 21 inches clearance in front of the air handler to permit maintenance and removal of filter.

- Position unit on suitable foundation. If a manufacturer approved accessory is not used, a frame strong enough to support the total weight of the unit, accessories, and duct work must be provided.
- Isolate unit from the foundation using a suitable isolating material.

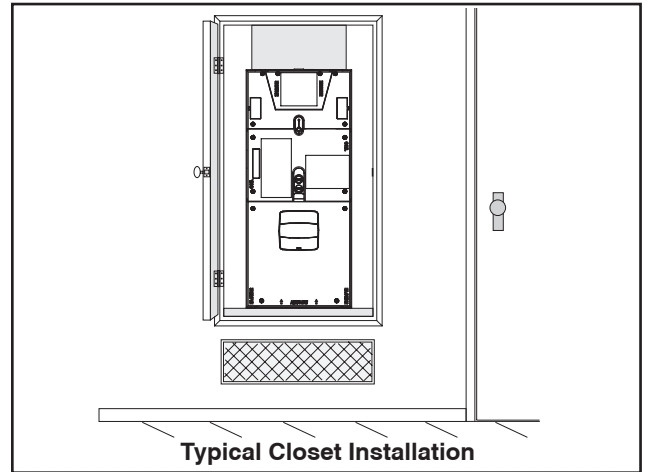

7.2 Upflow Installation

TASB Installation

1. Assemble the TASB using the stand's Installer Guide.

Contact your distributor for information on the TASB accessories.

TASB175SB is used with 17.5" cabinets

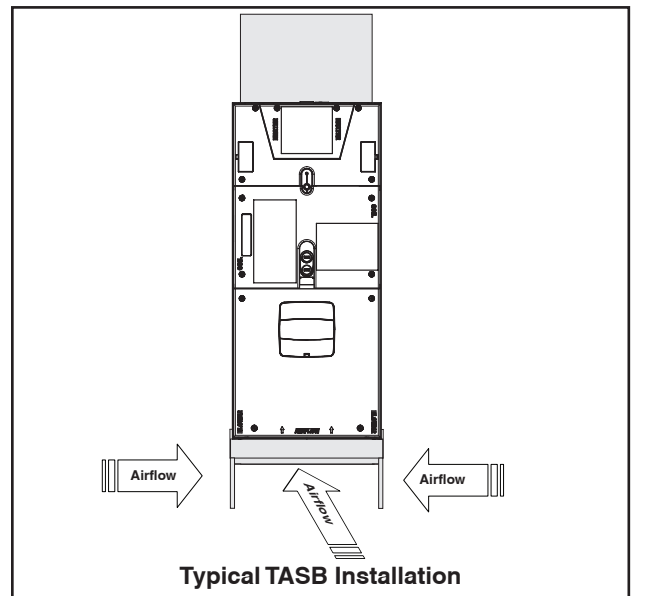

Plenum Installation

1. Assemble the plenum using the plenum's Installer Guide.

On units with sheet metal returns: Return plenum must be flanged. Sheet metal drill point screws must be 1/2" in length or shorter.

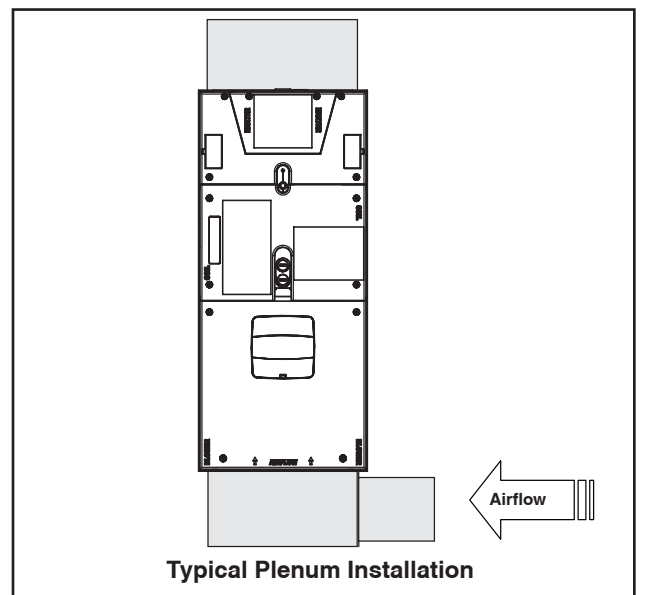

Section 8. Setting the Unit – Horizontal Installation

8.1 Considerations

Important: Due to the unique design of this unit, which allows the electrical wiring to be routed within the insulation, do not screw, cut, or otherwise puncture the unit cabinet in any location other than the ones illustrated in this Installer Guide or in an approved accessory's Installer Guide.

Important: Make certain that the unit has been installed in a level position to ensure proper draining.

Important: Under no conditions should metal strapping be attached to the unit to be used as support mechanisms for carrying or suspension purposes.

STEP 1 - Support the unit from the bottom (near both ends). The service access must remain unobstructed.

Important: The unit can only be supported from the bottom. Do not drill or screw supports into any area of the cabinet.

Note: Do not allow the unit to be used as strain relief.

- Approved bottom support methods are rails, u-channels (Unistrut®), or other load bearing materials.
- The unit must be isolated carefully to prevent sound transmission. Field supplied vibration isolators are recommended.

STEP 2 – Install an auxiliary drain pan under the horizontal air handler to prevent possible damage to ceilings.

- Isolate the auxiliary drain pan from the unit and from the structure.
- Connect the auxiliary drain pan to a separate drain line and terminate according to local codes.

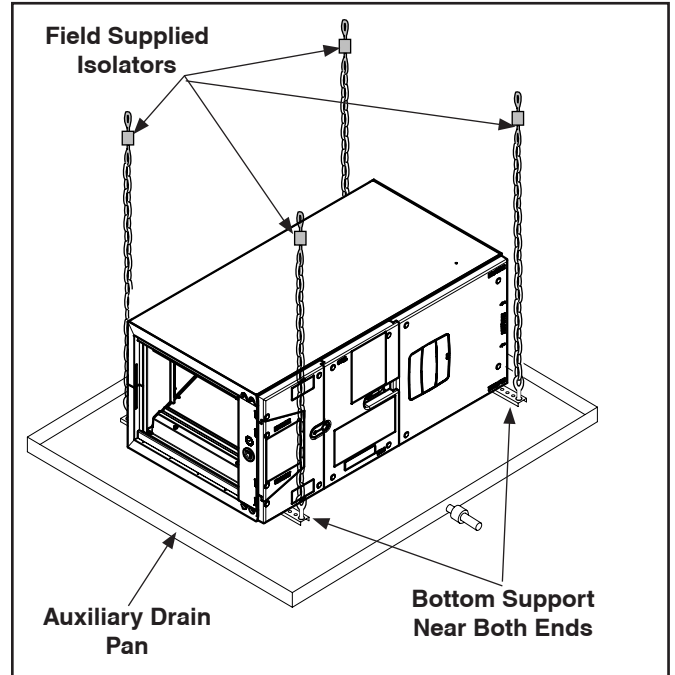

Section 9. Connecting the Ductwork

9.1 Duct Connection Considerations

Important: Due to the unique design of this unit, which allows the electrical wiring to be routed within the insulation, do not screw, cut, or otherwise puncture the unit cabinet in any location other than the ones illustrated in this Installer Guide or in an approved accessory's Installer Guide.

Important: Under no conditions should metal strapping be attached to the unit to be used as support mechanisms for carrying or suspension purposes.

Important: On units with sheet metal returns: Return air plenum must be flanged. Sheet metal drill point screws must be 1/2" in length or shorter.

- The supply and return air ducts must be connected to the unit with non flammable duct connectors.
- See the Outline drawing for sizes of the duct connections.
- After the ducts are secured, seal around the supply and return ducts to prevent air leakage.
- Insulate all duct work that will be outside of conditioned spaces.
- Convertible Duct Flange Kits are available to connect the supply plenum or for mounting on the discharge opening to provide a "flush fit" for 1-1/2" duct board applications.
- If front or rear return is required, the air handler must be elevated - placed on a pedestal or plenum and duct must be connected to this pedestal or plenum.
- If side return is required, the Side Return Kit # BAYSRKIT100A accessory must be used. A remote filter will be required.
- To ensure maximum efficiency and system performance, the existing supply and return duct system static pressures must not exceed the total available static pressure of the air handler. Reference ACCA Manual D, Manual S and Manual RS along with the air handler Product Data and Service Facts for additional information.

Note: Side return is not approved without Side Return Kit # BAYSRKIT100. More than one Side Return Kit may be necessary depending on the application. Refer to the Installation Guide in BAYSRKIT100 for approved duct connections, sizing, number, transitions, and accessory application.

Note: Duct work must be supported as appropriate. See National and local codes for guidelines. Do not depend on the unit to support duct work.

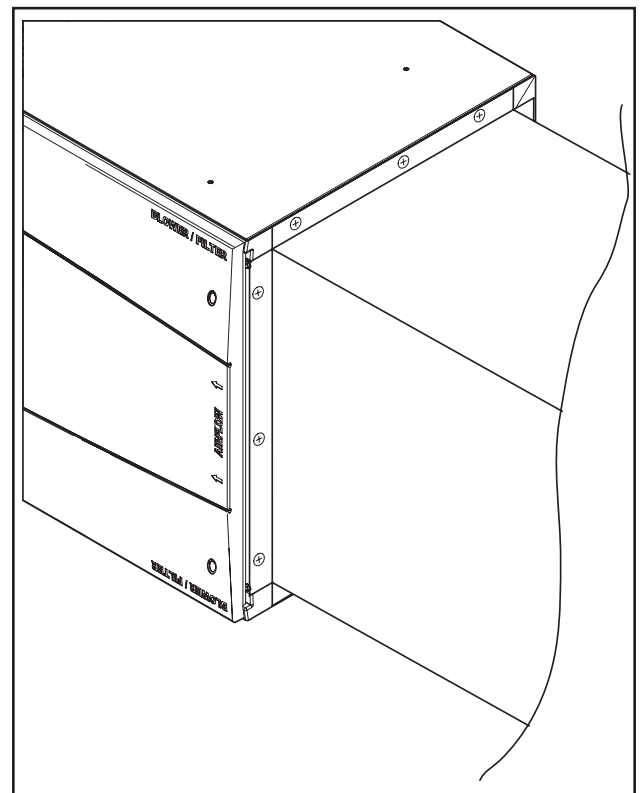
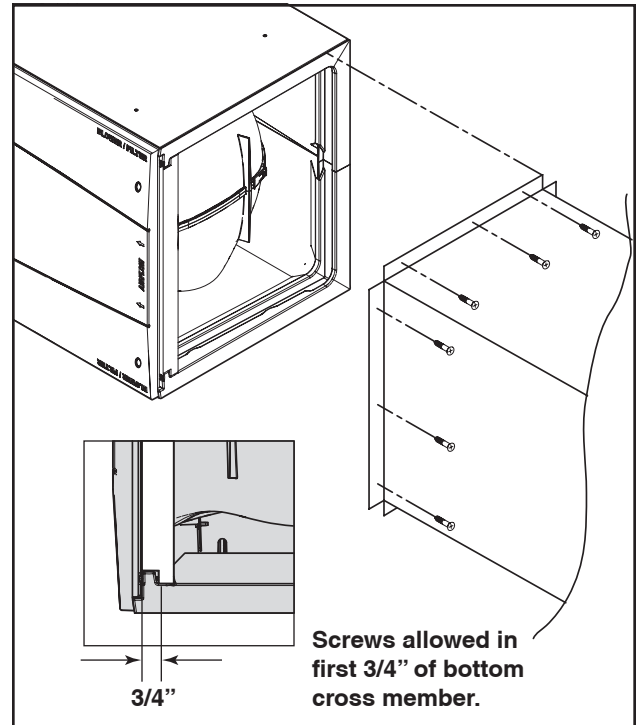

Section 10. Refrigerant Line

10.1 Refrigerant Line Connection Sizes

Table 10.1

Refrigerant Line Set and Connection Sizes		
Model	Vapor Line Connection	Liquid Line Connection
GAF2A0A18S11EE, GAF2A0A18S11SE	3/4	3/8
GAF2A0A24S21EE, GAF2A0A24S21SE	3/4	3/8
GAF2A0A30S21EE, GAF2A0A30S21SE	3/4	3/8
GAF2A0A36S31EE, GAF2A0A36S31SE	3/4	3/8

Notes:

1. This table indicates the tubing connection diameters at the indoor coil. A field supplied reducing coupling may be required.
2. All AHRI listed systems are tested with 25 feet of refrigeration tubing; the rated tubing diameters are located in the electronic performance data system.
3. If the refrigeration lines exceed 60 feet in linear length and / or if alternate size refrigeration tubing is present at the job, please consult SS-APG006-EN or 32-3312-**(latest version)

10.2 Refrigerant System Layout

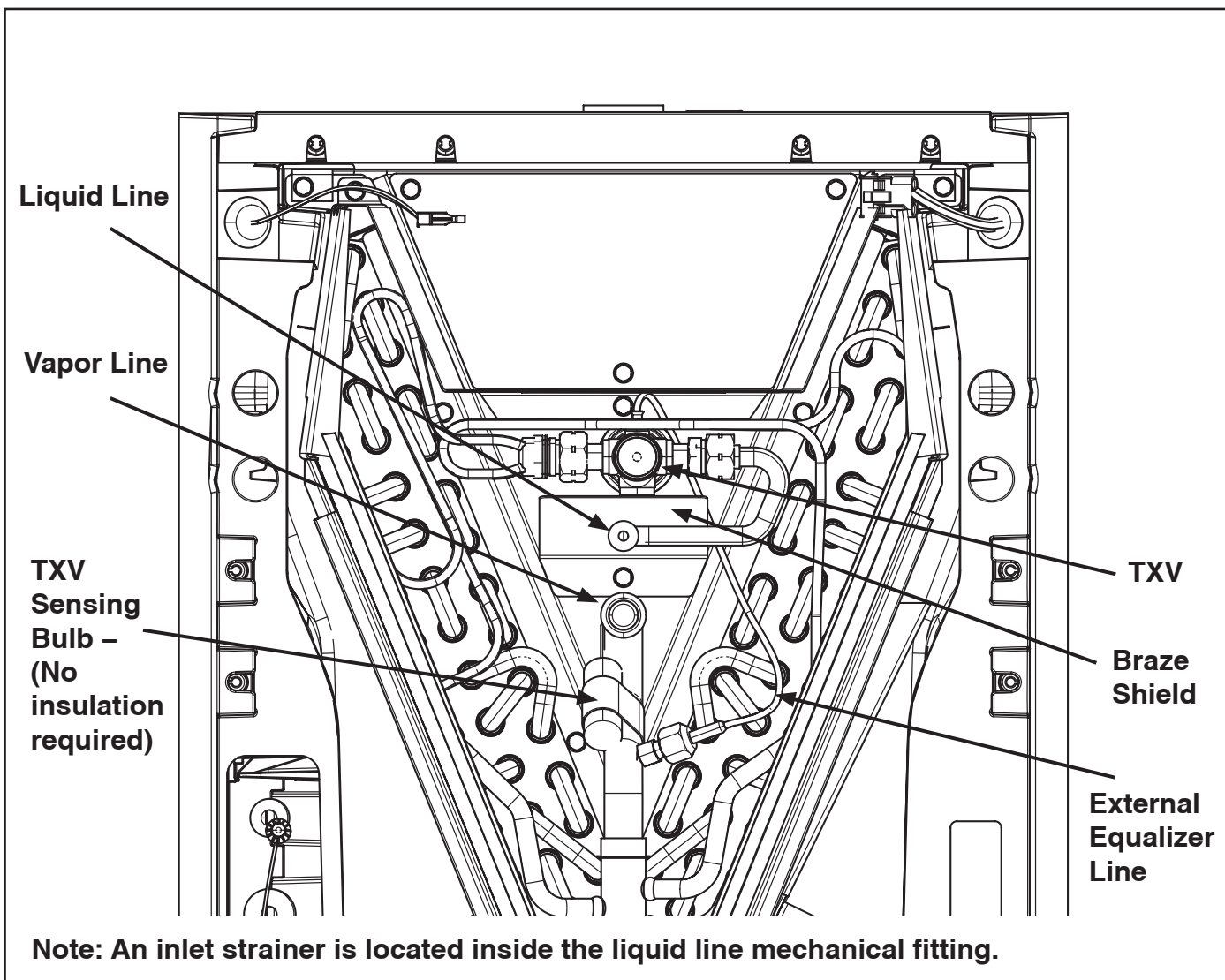

Section 11. Refrigerant Line Brazing

11.1 Braze The Refrigerant Lines

STEP 1 - Remove Heater, Coil, and Line Set panels.
(See Section 2.2 Panel Removal)

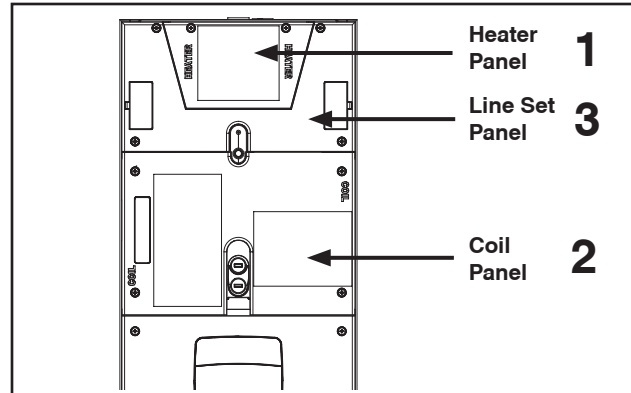

Important: Do NOT unseal coil refrigerant connection stubs until ready to make connections.

Important: Heat Sensitive Bulb.

The TXV sensing bulb must be removed or a wet rag must be wrapped around the suction line between the Bulb and the braze joint to protect the Bulb from failure due to overheating.

Caution: This coil is pressurized with 8-12 psig of dry air. Do not stand directly in front of the coil connections when removing sealing plugs.

STEP 2 - Remove the sealing plug from the indoor coil suction (vapor) line.

STEP 3 - Remove the sealing plug from the indoor coil liquid connection.

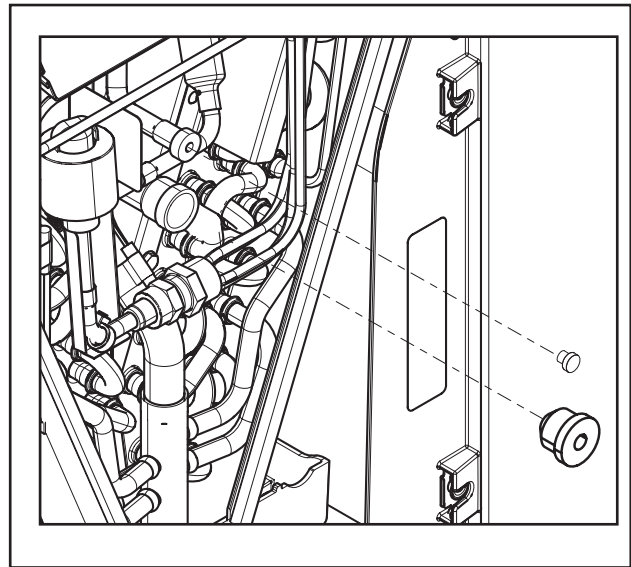

STEP 7 - Connect, but do not braze, field line set to indoor coil.

Allow a minimum of 1.5 inches of refrigerant line set before using an elbow coupling.

Important: Service access to the auxiliary heater must remain unobstructed.

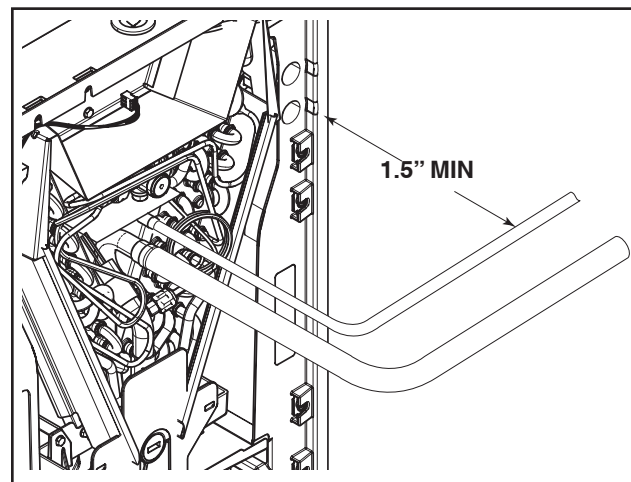

Important: Heat Sensitive Bulb.

The temperature Bulb must be removed or a wet rag must be wrapped around the suction line between the Bulb and the braze joint to protect the Bulb from failure due to overheating.

STEP 8 - Braze refrigerant line connections.

Note: The suction line must be insulated prior to brazing the line set to the air handler stubs.

1. Pull back the insulation before brazing the suction line.
2. Wrap the TXV sensing bulb and line section between the bulb and braze with a wet rag.
3. Braze the refrigerant line connections.

Important: Care must be taken during brazing to avoid damage to unit components and wiring.

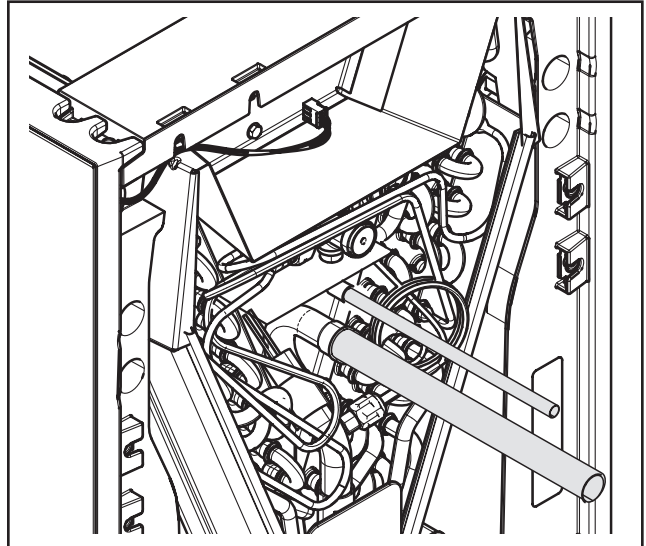

STEP 9 - Pressurize the refrigerant lines and evaporator coil to 150 PSIG using dry nitrogen.

150 PSIG

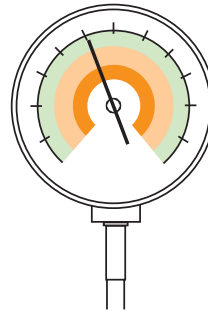

STEP 10 - Check for leaks by using a soapy solution or bubbles at each brazed location.

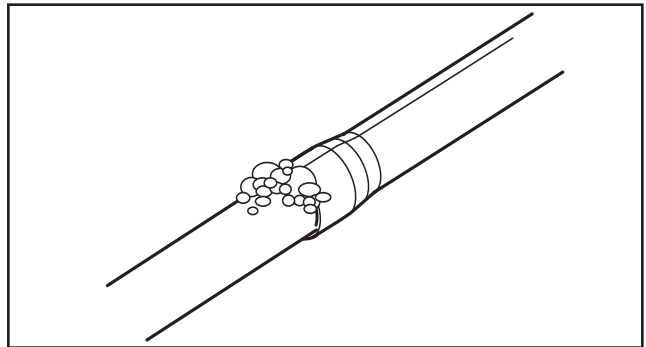

STEP 11 - Place the TXV sensing bulb back into the clip on the Vapor Line. Insulation over the TXV bulb is not required.

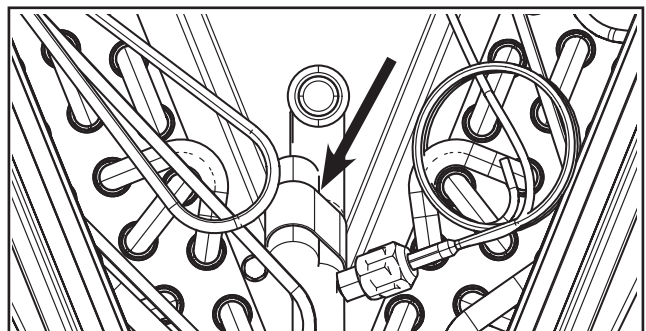

Important: Do not open the service valves until the refrigerant lines and indoor coil leak check and evacuation are complete.

STEP 12 - Evacuate until the micron gauge reads no higher than 350 microns, then close off the valve to the vacuum pump.

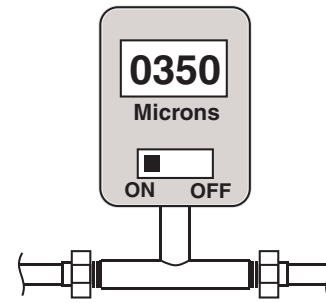

STEP 13 - Observe the micron gauge. Evacuation is complete if the micron gauge does not rise above 500 microns in one (1) minute.

Once evacuation is complete blank off the vacuum pump and micron gauge, and close the valves on the manifold gauge set.

Note: Charge system using Outdoor unit's Installer Guide or Service Facts.



STEP 14 - Replace the Line Set panel.

1. Allow time for tubing to cool.
2. Install grommet onto line set piping.

Note: A slight amount of dish soap can be used to aid in the installation of the grommet. Remove any excess from the tubing and grommet after the grommet is installed.

3. Slide the bottom of the Line Set panel down over the refrigerant lines and grommet. The grommet will seal the line openings.

Note: If installing in a horizontal application, complete the condensate connection preparations per Section 12, Step 3 before installing the Line Set panel.

4. Tighten screws on the Line Set panel.

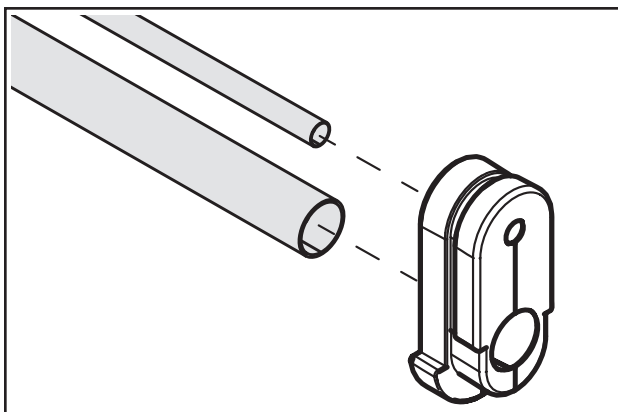
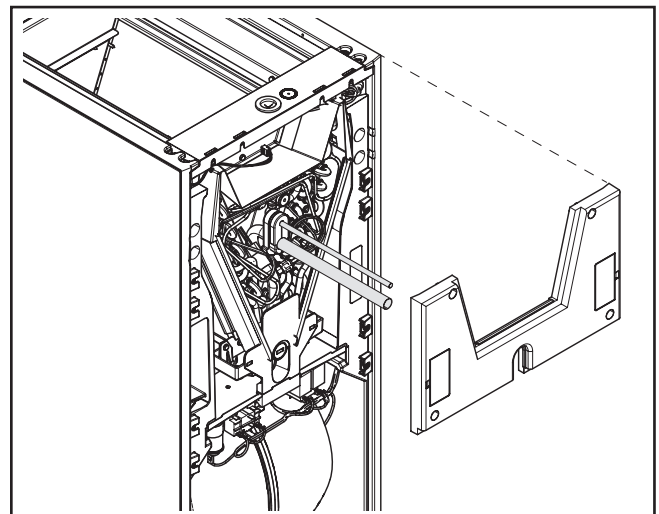
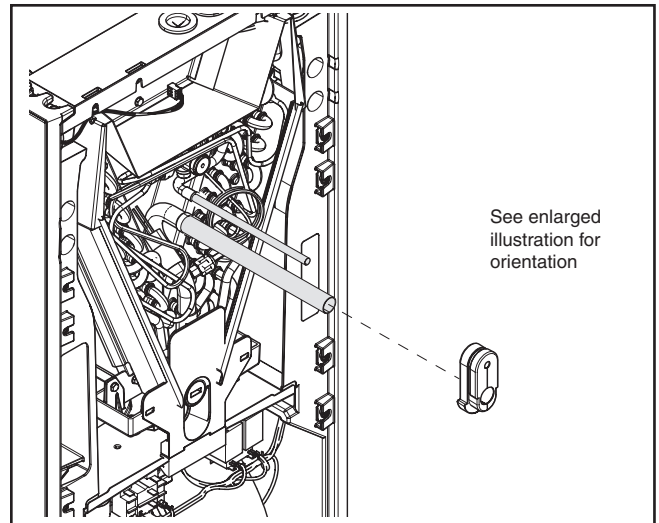

Section 12. Condensate Drain Piping

12.1 Condensate Drain Piping Considerations

- Condensate drain plumbing must comply with national, state, and local codes.
- Route condensate drain lines away from air handler so they do not interfere with access panels.
- Slope the drain lines downward a minimum of 1/4" per foot, support per local codes.
- A 1.5" minimum distance from the coil panel to the inside of the condensate tubing is recommended for coil panel removal.
- Do not use reducing fittings in the condensate drain lines.
- Do not connect the drain line to a closed drain system.
- Do not use a torch or flame near the plastic drain pan coupling.
- A P-trap is not required for proper drainage due to the positive pressure of the air handler; however, it is recommended to prevent efficiency loss of conditioned air.

12.2 Connect Condensate Drain Piping

Note: Upflow and horizontal orientations require the Coil panel to be removed in order to make the drain connections. **Note:** Make certain that the unit has been installed in a level position to allow for proper draining.

STEP 1 - Select the drain connections that are oriented for your application.

STEP 2 - Prepare the condensate drain connections.

- From the factory, the unit comes with plugs in both upflow condensate drains and an additional plug in the documentation packet.
- For upflow applications, remove upflow condensate plug(s) and connect condensate piping.
- For horizontal applications, do not remove upflow condensate plugs. Remove the cover from the needed condensate drain connections and connect condensate piping.
- If the secondary condensate opening is not used, plug the condensate opening with the fitting supplied in the documentation pack. Use scissors to cut the air seal in half and re-install over the unused opening.

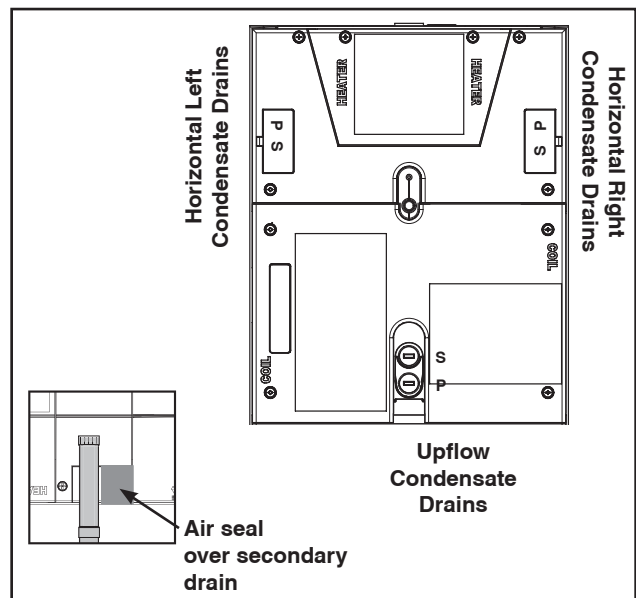

Note: A small amount of sealant must be applied around the drain line(s) passing through the panel to prevent air leakage and possible water drips.

- **Dry fit and test clearance for coil panel removal before applying PVC/CPVC cement**
- **Use Teflon tape on the air handler drain line connections. Do not use pipe joint compound or PVC/CPVC cement on drain nipple.**
- **Hand tighten the drain pipe.**

STEP 3 - For Upflow installations, connect 3/4" PVC pipe to the threaded drain nipple with PVC/CPVC cement. 1.5" minimum clearance to the condensate piping is needed for coil panel removal. Thread the assembly into the primary drain connection (repeat for the secondary drain connection if used).

Important: For horizontal applications, the following order must be observed:

- 1) Remove panel and insert the 3/4" nipples.
- 2) Reinstall the panel.
- 3) Connect the condensate lines to the nipples.

Note: A small amount of sealant must be applied around the drain line(s) passing through the panel to prevent air leakage and possible water drips.

Optional pipe kit BAYCNDPIP01A is available (10 pcs per kit).

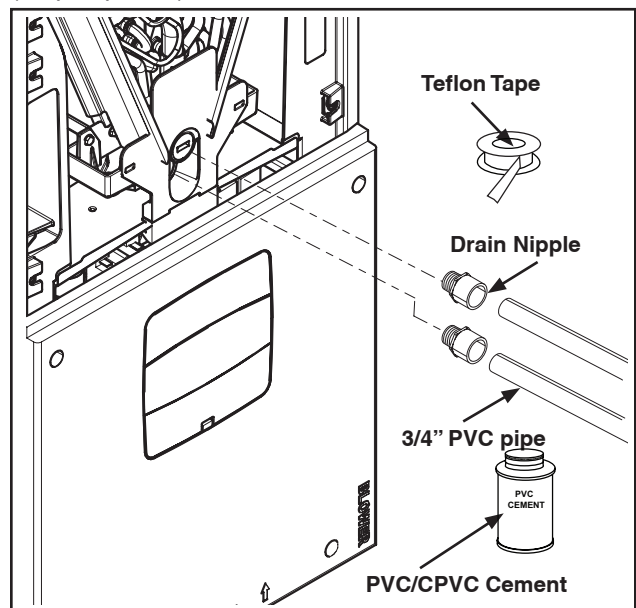

STEP 4 - Install a clean-out tee in the primary drain line for future maintenance. It is recommended that you install a cap on the top of the tee.

1.5" minimum clearance is recommended from cabinet to inside edge of tubing

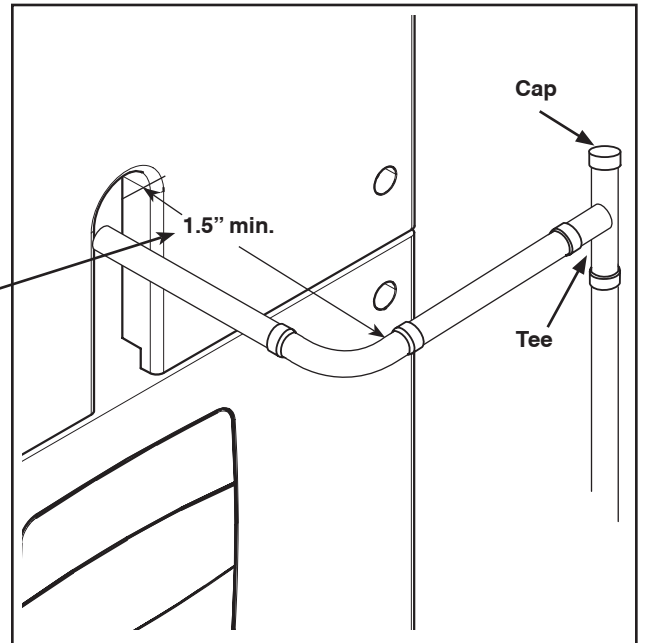

STEP 5 - Insulate the primary drain line to prevent sweating where dew point temperatures may be met. (Optional depending on climate and application needs.)

Provide a means of drainage to prevent winter freeze-up of condensate line. (Optional depending on climate and application needs.)

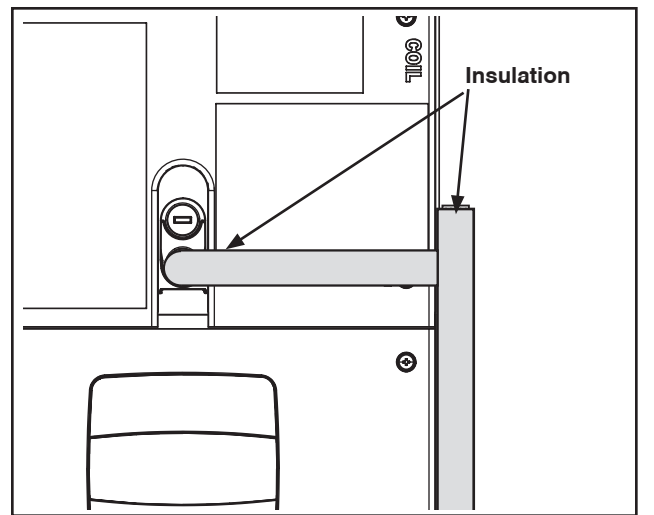

STEP 6 - Support the condensate piping outside the unit per local codes for proper drainage and to prevent sagging.

Allow 1/4" of downward slope for each foot of pipe.

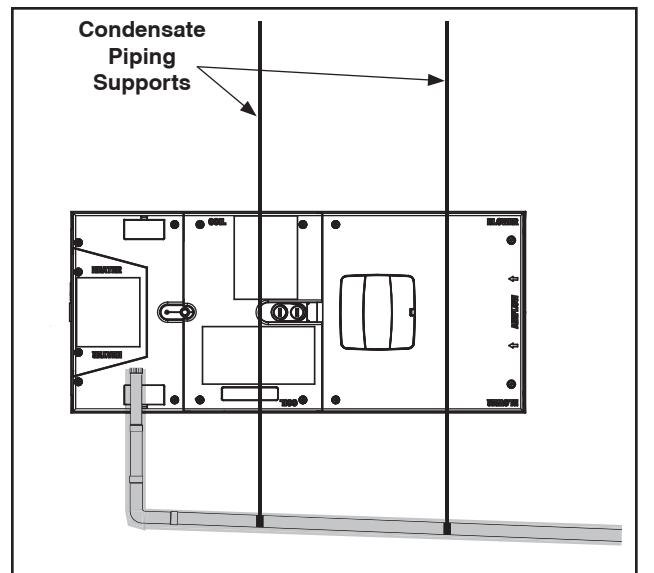

Section 13. Electrical – Low Voltage

13.1 Low Voltage Maximum Wire Length

Table 13.1 defines the maximum total length of low voltage wiring from the outdoor unit, to the indoor unit, and to the thermostat.

Table 13.1

24 VOLTS	
WIRE SIZE	MAX. WIRE LENGTH
18 AWG	150 Ft.
16 AWG	225 Ft.
14 AWG	300 Ft.

13.2 Low Voltage Hook-up Instructions

STEP 1 - Remove Coil and Blower panels by removing the four fasteners on each panel and then pulling away from the cabinet to remove.

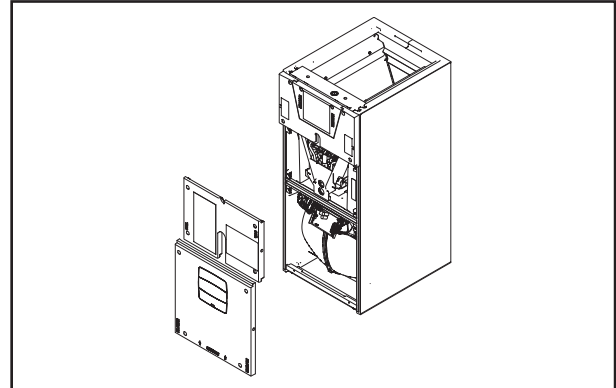

STEP 2 - For Low voltage entry, drill a .5" diameter hole size in side of blower cabinet at location shown on illustration. A 3/8" bushing is supplied in the doc pack.

STEP 3 - Route control wiring to unit and Insert Low voltage wiring.

Note: After the Low voltage wiring has been inserted through the new hole, the hole must be sealed.

Note: If a side return kit is used, the Low voltage entry must be on the opposite side of the air handler.

Note: When drilling access through cabinet do not drill into any internal components. Remove internal components before drilling through cabinet if possible. Damage to the air handler or heater could result.

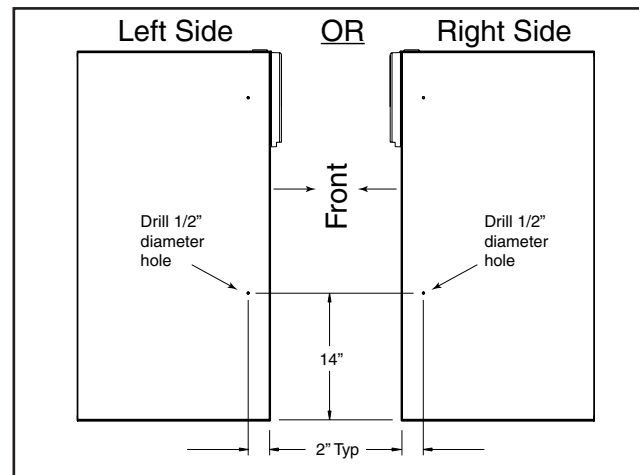

Note: Strain relief must be provided on the inside of the air handler cabinet for the low voltage wiring. Field supplied thermostat wires may be wire tied as a bundle to the existing strain relieved low voltage pigtail leads in the air handler unit.

STEP 4 - Remove the external sheathing of the wiring approximately 5".

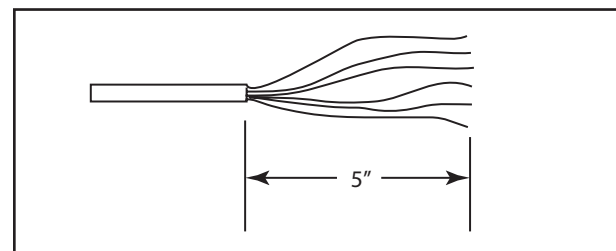

STEP 3 - Make connections per hookup diagrams.
Tuck the wire nut connections into the recess in the cabinet wall.

**Air Handler Hook-up Diagram
Cooling**

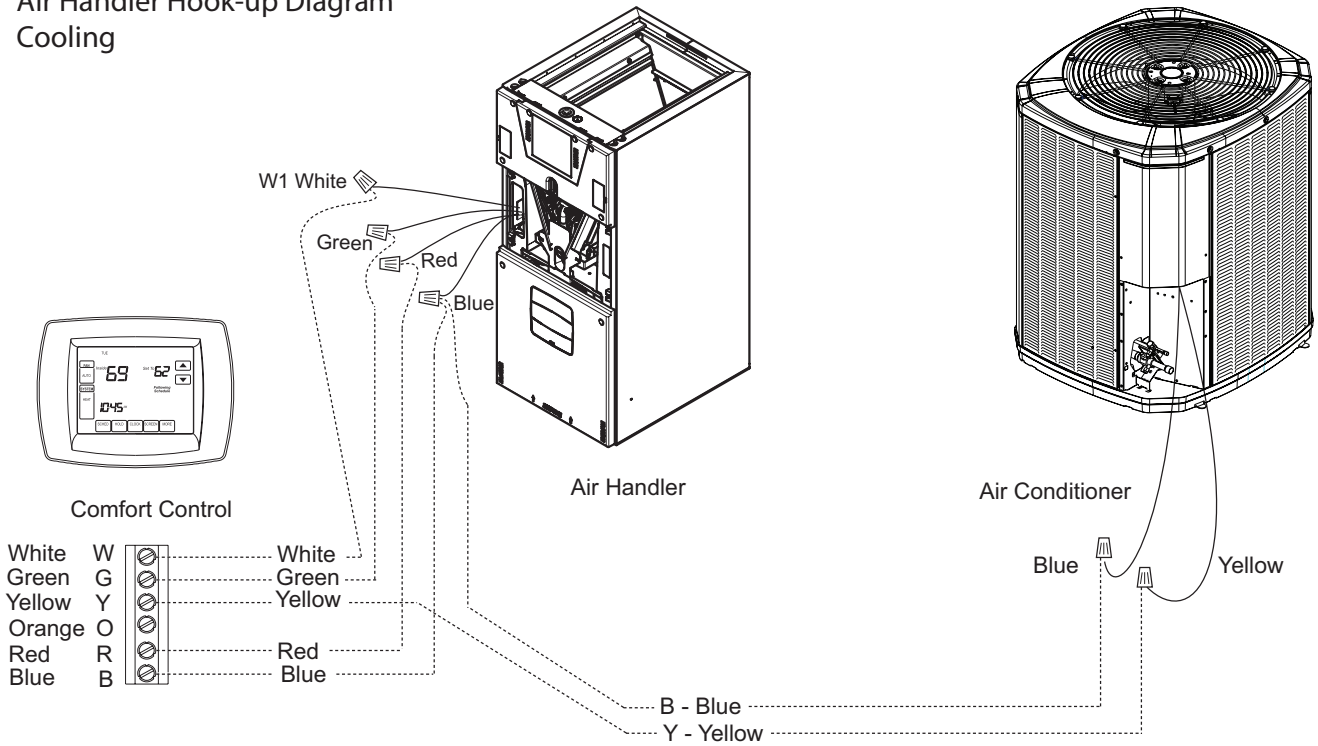

..... Field wiring

**Air Handler Hook-up Diagram
HP**

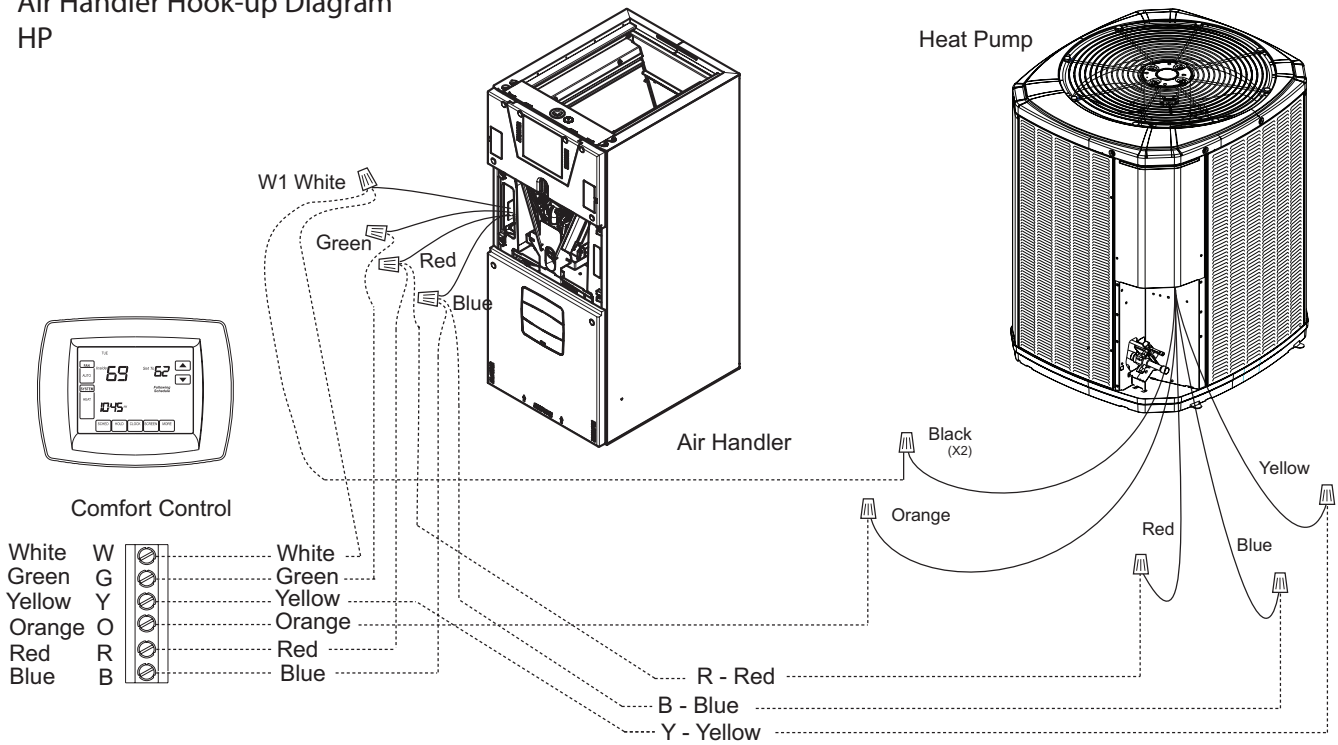

..... Field wiring

STEP 4 - Replace Coil panel making sure that the wires are located within the wire pass-through provided in the panel.

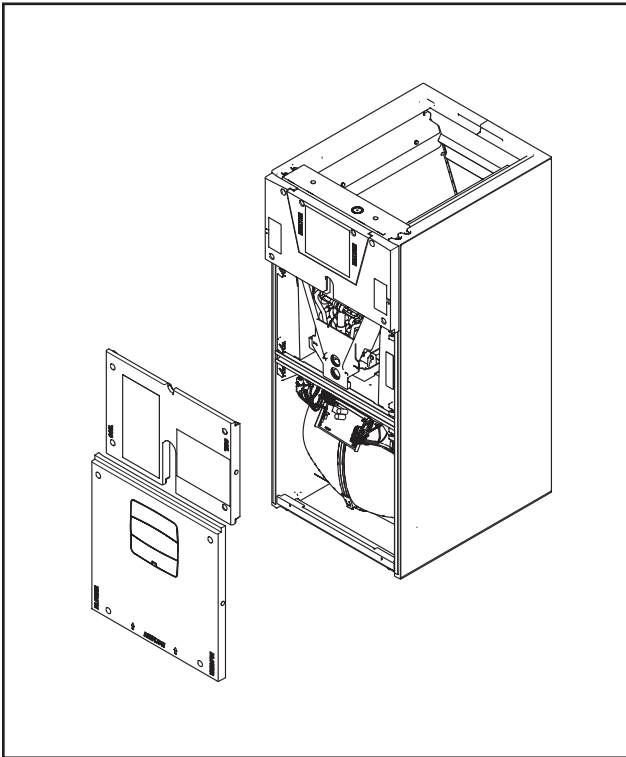

Section 14. Electrical – High Voltage

14.1 High Voltage Power Supply

The high voltage power supply must match the equipment nameplate.

Power wiring, including ground wiring, must comply with national, state, and local codes.

Field wiring diagrams for supplementary electric heaters are shipped with the heater.

⚠ WARNING

LIVE ELECTRICAL COMPONENTS!

During installation, testing, servicing, and troubleshooting of this product, it may be necessary to work with live electrical components. Failure to follow all electrical safety precautions when exposed to live electrical components could result in death or serious injury.

14.2 Make Electrical Connections

STEP 1 - Route High Voltage wiring to unit.

STEP 2 - The conduit entry point is located on the top of the unit when in the Upflow configuration. Drill a hole for the desired conduit size (up to 3/4") on units without a plug. A locating target is identified on the unit.

Note: If a hole is already present, remove the plug from the entry point and use as is.

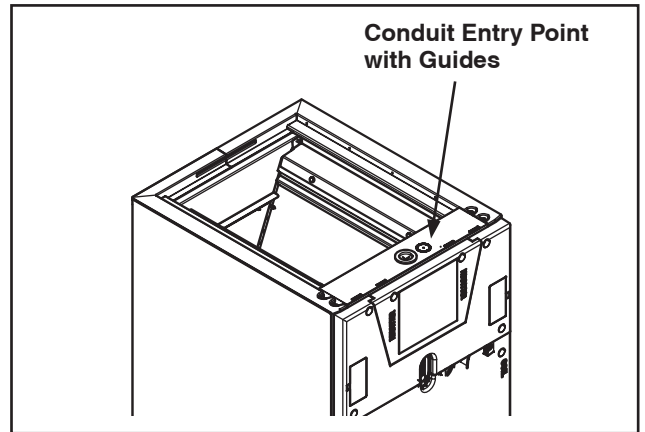

STEP 3 - Route conduit (if used) to the entry point and connect.

1. Use one hand to secure the conduit nut from inside of the heater compartment.
2. Connect field supplied conduit (up to 3/4") to conduit nut.

Note: Reducing bushings may be required for your application.

Note: When drilling access through cabinet do not drill into any internal components. Remove internal components before drilling through cabinet if possible. Damage to the air handler or heater could result.

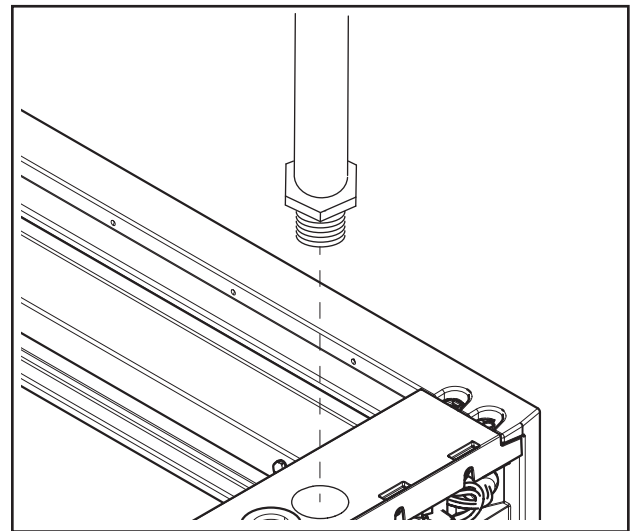

STEP 4 - If an electric heater IS NOT being installed, remove the pigtail harness from the documentation pack and connect it to the plug on the inside of the Heater Compartment in the cabinet.

If an electric heater IS being installed, see the Installer's Guide shipped with the electric heater.

Connect L1, L2, and ground wiring to pigtail harness in Heater Compartment using wire nuts. The incoming ground wiring will mate up with the green wire shown in the illustration.

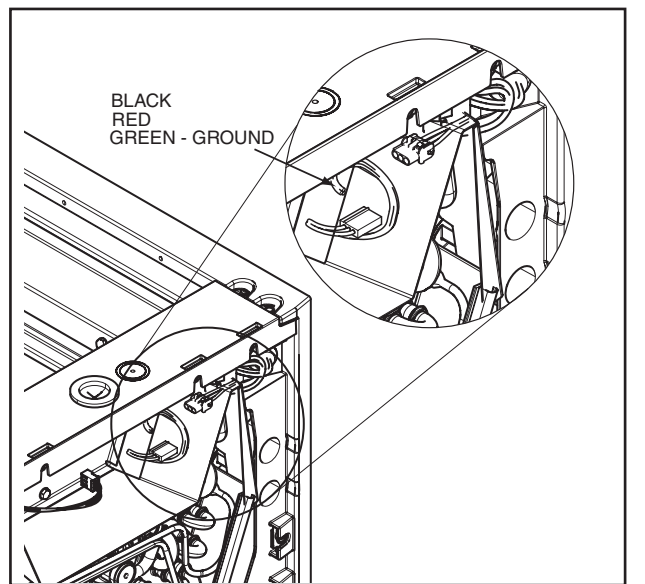

STEP 5 - Reinstall all panels before starting the air handler.

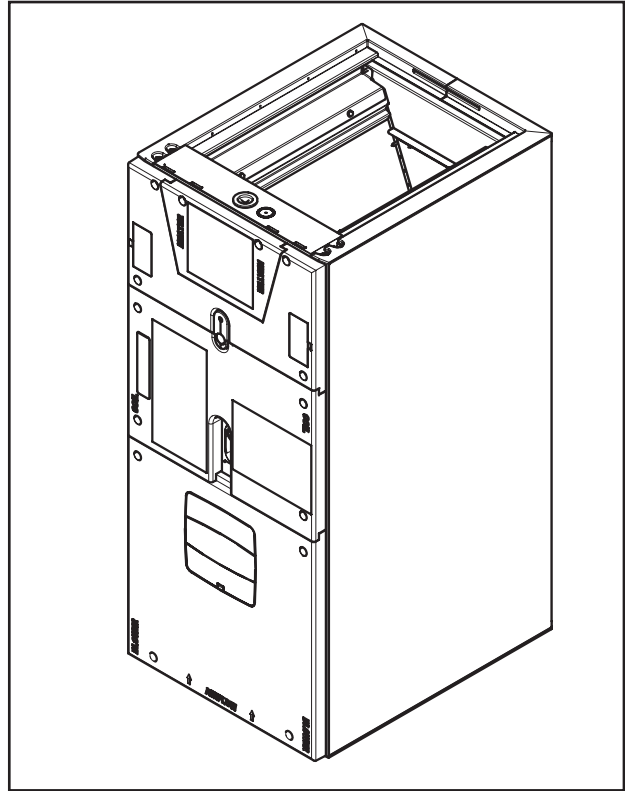

Section 15. Filters

15.1 Filter Considerations

- Since a filter option is not included within the air handler, a remote filter must be installed with the system.
- For customer ease of filter maintenance, it is recommended that a properly sized remote filter grill(s) be installed for units that are difficult to access. Airflow should not exceed the maximum rated velocity of the filter being used.
- A bottom return filter kit BAYBRFBX100 or a front return filter kit BAYFRKIT100 may be installed.

Table 15.1 Filter Sizes

Accessory Kit*	Filter Size
BAYBRFBX100	16" x 20"
BAYFRKIT100	16" X 16"

*Kits are for GAF2 one piece A Cabinets. Cabinet size is indicated by the 7th digit in model number.

Section 16. Unit Outline Drawing

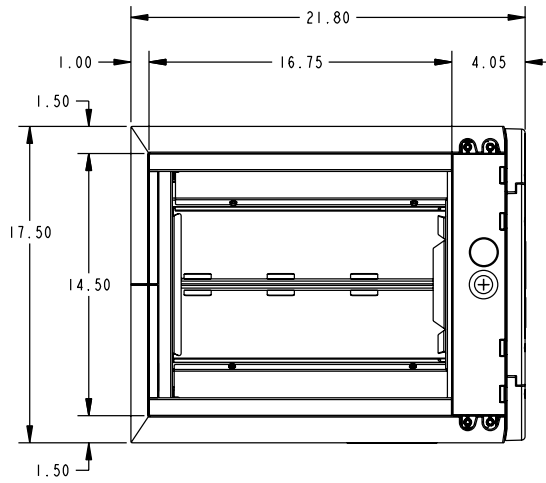

	TO COMBUSTIBLE MATERIAL (REQUIRED)	SERVICE CLEARANCE (RECOMMENDED)
SIDES	0"	2"
FRONT	0"	21"
BACK	0"	0"
INLET DUCT	0"	N/A
OUTLET DUCT	0"	N/A

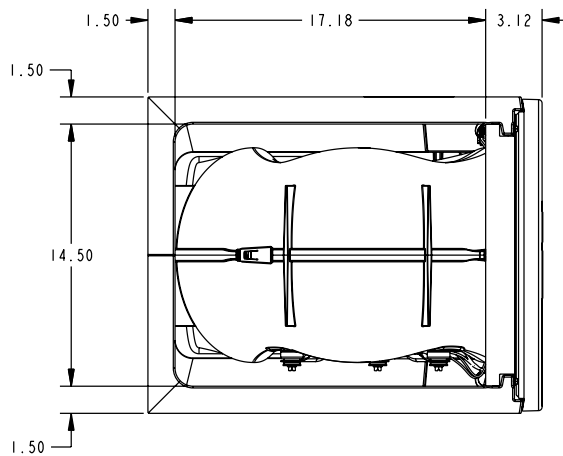
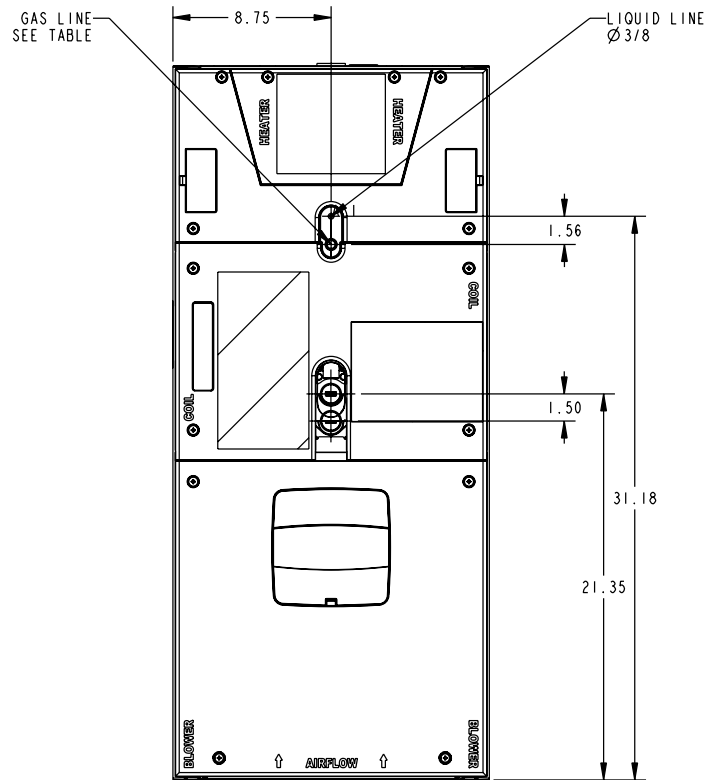
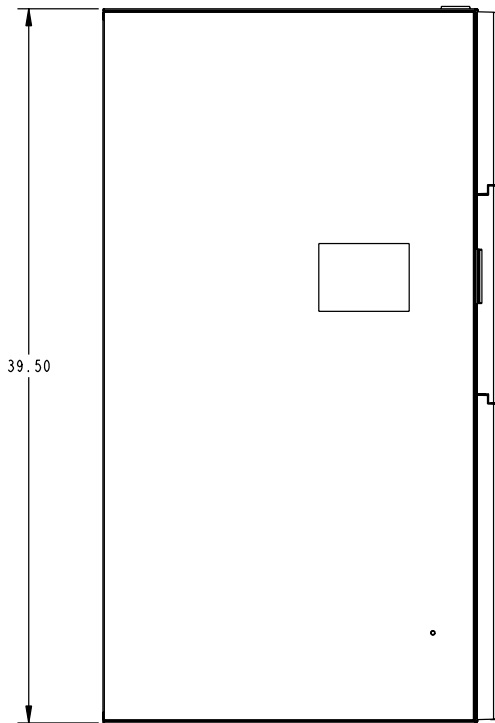

MODEL NO.	FLOW CONTROL	LIQUID LINE BRAZE	GAS LINE BRAZE
GAF 2A0A18*	TXV	3/8	3/4
GAF 2A0A24*	TXV	3/8	3/4
GAF 2A0A30*	TXV	3/8	3/4
GAF 2A0A36S*	TXV	3/8	3/4
GAF 2A0A36M*	EEV/24V	3/8	3/4

Section 17. Start Up

17.1 System Charge Adjustments

System Matched with:	Indoor Unit Model No.	Outdoor Unit Model No.	Subcooling
13 SEER HP	GAF2A0A36S31	4TWR3036C1 4A6H3036C1 4TWB3036C1	6°

All other matches must be charged per the nameplate charging instructions.

17.2 System Start Up

STEP 1 - Make sure all panels are securely in place and that all wiring has been properly dressed and secured.

STEP 2 - Set the system thermostat to OFF.

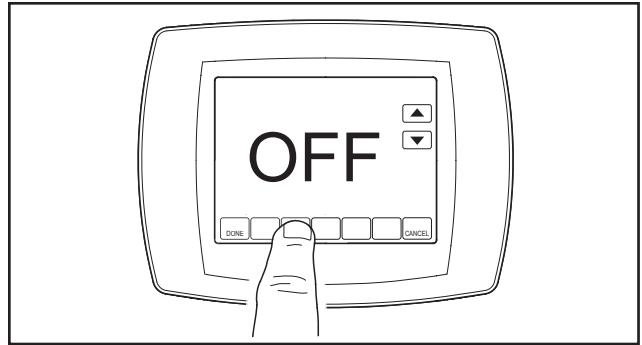

STEP 3 - Turn on electrical power disconnect(s) to apply power to the indoor and outdoor units.

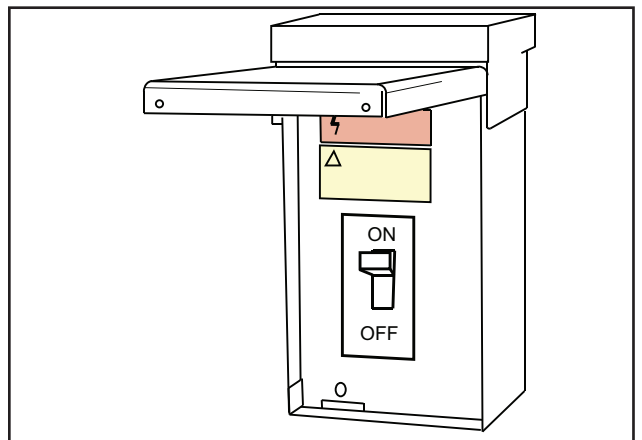

STEP 4 - Set the system thermostat to ON.

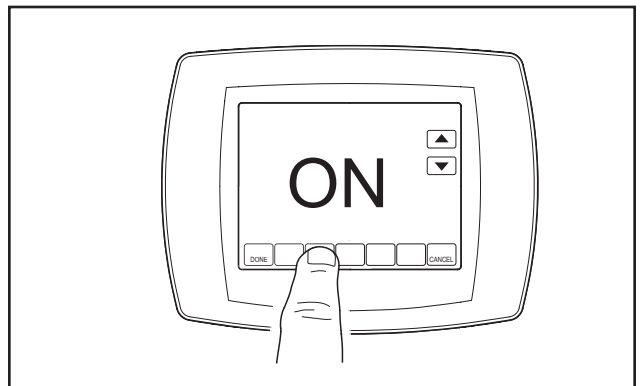

Section 18. Sequence of Operation

18.1 Sequence of Operation

GAF2 Sequence of Operation

See unit, electric heat, and field wiring diagrams for additional information.

Continuous Fan

1. R-G contacts close on comfort control sending 24VAC to the blower relay
2. Relay contacts 1 and 3 close.
3. The blower will now run on the selected speed. Speed is field selectable.

Heatpump OD (cooling)

1. R-Y contacts close on the comfort control sending 24VAC to the OD unit.
2. R-G contacts close on comfort control sending 24VAC to the blower relay
3. Relay contacts 1 and 3 close
4. The blower will now run on the selected speed. Speed is field selectable
5. R-O contacts on the comfort control close sending 24VAC to the switch over valve on the OD unit.

Heatpump OD (heating)

1. R-Y contacts close on the comfort control sending 24VAC to the OD unit.
2. R-G contacts close on comfort control sending 24VAC to the blower relay
3. Relay contacts 1 and 3 close.
4. The blower will now run on the selected speed. Speed is field selectable.

Cooling OD

1. R-Y contacts close on the comfort control sending 24VAC to the OD unit.
2. R-G contacts close on comfort control sending 24VAC to the blower relay
3. Relay contacts 1 and 3 close
4. The blower will now run on the selected speed. Speed is field selectable

Electric Heating

1. R-W contacts close on the comfort control sending 24VAC to energize the heat contactor.
2. R-G contacts close on comfort control sending 24VAC to the blower relay
3. Relay contacts 1 and 3 close
4. The blower will now run on the selected speed. Speed is field selectable
5. Contacts 4 & 6 on the blower relay close providing the interlock circuit to allow the electric heat relays to operate

Important: The comfort control must be setup to control R-G contacts with a call for electric heat. This closes the interlock circuit and allows the heat relay circuit to be energized.

Section 19. Checkout Procedures

19.1 Operational And Checkout Procedures

Final phases of this installation are the unit Operational and Checkout Procedures. To obtain proper performance, all units must be operated and charge adjustments made in accordance with procedures found in the Service Facts of the Outdoor Unit.

CHECKOUT PROCEDURE

After installation has been completed, it is recommended that the entire system be checked against the following list:

1. Be sure unit suspension (if used) is secure and that there are no tools or loose debris in or around or on top of the unit. []
2. Properly insulate suction lines and fittings. []
3. Properly secure and isolate all refrigerant lines. []
4. Verify that all electrical connections are tight. []
5. Check all duct outlets; they must be open and unrestricted. []
6. Check drain lines and be sure all joints are tight. []
7. Be sure the return air filter is installed. []
8. Be sure that the correct airflow setting is used. (Indoor Blower Motor). []
9. Operate complete system in each mode to verify proper performance. Verify operation of supplementary electric heater. []

About Trane and American Standard Heating and Air Conditioning
Trane and American Standard create comfortable, energy efficient indoor environments for residential applications.
For more information, please visit www.trane.com or www.americanstandardair.com



The manufacturer has a policy of continuous data improvement and it reserves the right to change design and specifications without notice. We are committed to using environmentally conscious print practices.

18-GJ24D1-9A-EN 20 April 2020
Supersedes 18-GJ24D1-9 (September 2018)

© 2020