



Whole House Electronic Air Cleaner

Upflow Furnace Models

EFD145DLFR000**
 EFD175DLFR000**
 EFD210DLFR000**
 EFD245DLFR000**

Downflow Furnace Models

EFD17DDLFR000**
 EFD21DDLFR000**

Air Handler Models

EFD175DLAH000**
 EFD215DLAH000**
 EFD235DLAH000**
 EFD260DLAH000**

50 Hz Air Handler Models

TFD215CLAH005E
 TFD235CLAH005E
 TFD260CLAH005E

ALL phases of this installation must comply with NATIONAL, STATE AND LOCAL CODES

IMPORTANT — This Document is **customer property** and is to remain with this unit.
 Please return to service information pack upon completion of work.

COMPONENTS OF THE AIR CLEANER

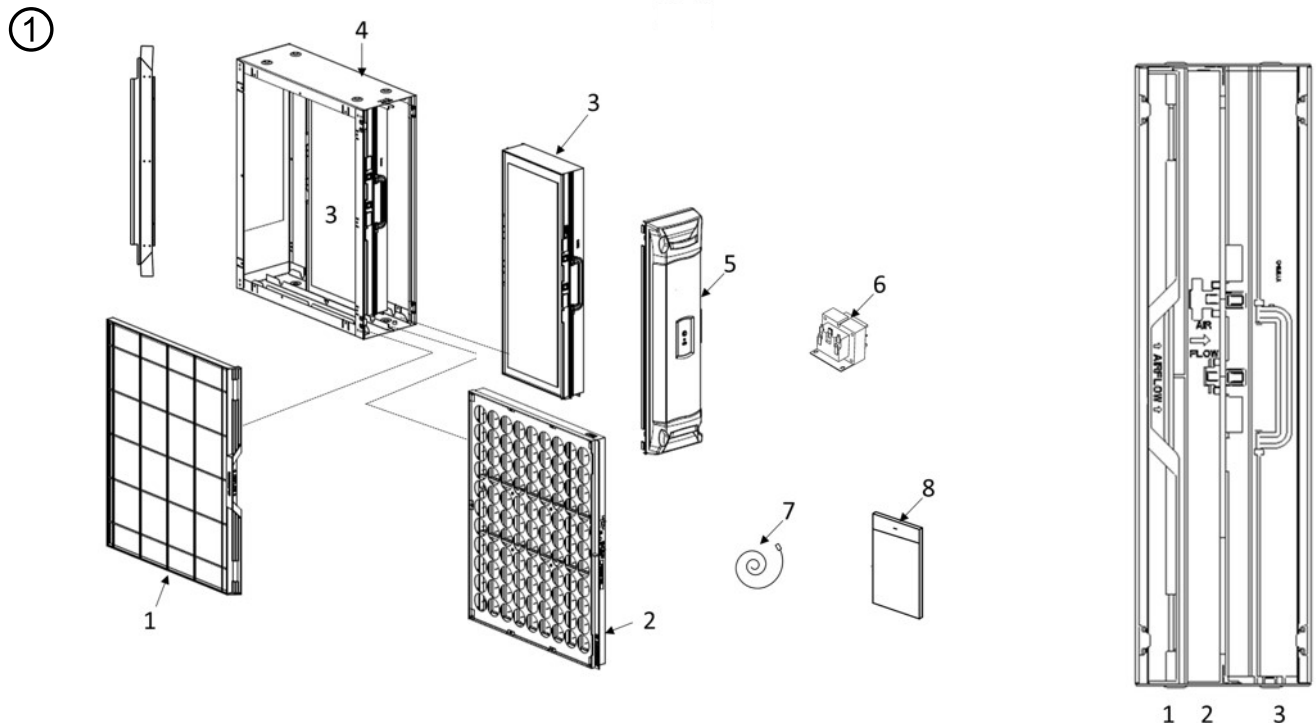

- 1) **PRE-FILTER** - traps large particles such as hair and lint before they can enter the COLLECTION CELL section.
- 2) **FIELD CHARGER** - Charges the contaminants. **Only to be serviced by a qualified technician.**
- 3) **COLLECTION CELL (2)** - removes and collects very small impurities from the air.
- 4) **CABINET** - mounts between the furnace/air handler and return air duct work and houses the COLLECTION CELLS, FIELD CHARGER and PRE-FILTER.

- 5) **POWER DOOR** - the solid state power supply components that convert the 24 Volt AC to the high-voltage, direct current required to power the FIELD CHARGER and COLLECTION CELLS. Allows access to the COLLECTION CELLS, FIELD CHARGER and PRE-FILTER.
- 6) **TRANSFORMER** - supplies 24 Volts to the indoor unit and Air Cleaner (not available with 50 Hz units)
- 7) **24 VOLT POWER / CONTROL CABLE**
- 8) **GASKET, LITERATURE AND HARDWARE PACKET**

⚠ WARNING

This information is for use by individuals having adequate backgrounds of electrical and mechanical experience. Any attempt to repair a central air conditioning product may result in personal injury and/or property damage. The manufacturer or seller cannot be responsible for the interpretation of this information, nor can it assume any liability in connection with its use.

⚠ CAUTION

RECONNECT ALL GROUNDING DEVICES.

All parts of this product that are capable of conducting electrical current are grounded. If grounding wires, screws, straps, clips, nuts, or washers used to complete a path to ground are removed for service, they must be returned to their original position and properly fastened.

Service Facts

INTRODUCTION

The whole house air cleaner can be installed either as part of a Communicating heating and air conditioning system or as part of a traditional 24 volt system.

When installed as part of a Communicating System in which the indoor unit, outdoor unit, and 900 series comfort control are equipped with our exclusive Communicating technology, this system performs a continuous loop of system diagnostics and data output. The Communicating System monitors itself and quickly identifies any operational faults, automatically issuing a service alert if needed.

The whole house air cleaner can also be installed as part of a traditional 24 volt heating and air conditioning system.

MODES OF OPERATION

The whole house air cleaner can be connected in one of two modes of operation; either a 24 V mode or a communicating mode. To know how the whole house air cleaner is set up, reference Figure 1a to find the amber light.

A steady amber light indicates that the unit is wired in the 24 V mode.

A blinking amber light indicates that the unit is wired in the communicating mode.

No light present means that the unit is not connected.

⚠ CAUTION

SAFETY HAZARD

Sharp Edge Hazard. Be careful of sharp edges on equipment or any cuts made on sheet metal while installing or servicing. Personal injury may result.

ELECTRICAL CONNECTIONS

The air cleaner requires 24 VAC power and indoor fan signal to operate. A transformer adequately sized to power both the system and air cleaner is provided with the air cleaner. Remove the transformer in the indoor unit and replace with the transformer provided.

NOTE:

- A 50 VA transformer is required for Trane/ American Standard Heating & Air Conditioning furnace applications.

- For Trane/American Standard Heating & Air Conditioning air handler applications, a 75 VA transformer is required. Replacement of the fuse is also needed. Remove the quick blow 5 Amp fuse and connect the supplied 3.2 Amp slow blow fuse assembly in its place.

NOTE: Trane/American Standard Heating & Air Conditioning dual circuited air handlers matched with heat pumps and Trane/American Standard Heating & Air Conditioning oil furnaces will require an accessory Transformer KIT# BAYTRANS12024♦ to power the air cleaner. Do NOT replace air handler transformer with the transformer supplied with the air cleaner.

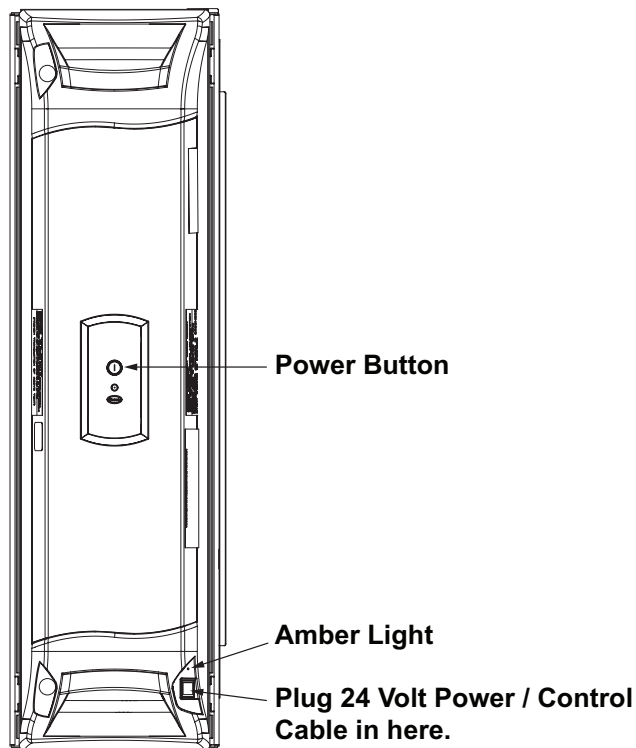

NOTE: When more than one whole house air cleaner is used, the 24 volt transformer which supplies power to the air cleaner will need to be increased by 25 VA for each additional air cleaner added.

NOTE: Provide adequate strain relief for the low voltage cable at the indoor unit.

NOTE: Wiring penetration must be sealed.

⚠ CAUTION

DO NOT attach the power/control cable to a 120 Volt EAC tap. The air cleaner uses 24 Volt power. Failure to use 24 VAC results in permanent damage to the air cleaner.

- Plug the air cleaner power/control cable into the air cleaner door and route the cable into the indoor unit low voltage wiring location.
- Connect the power/control wiring per Figure 2.

NOTE: For non-Trane/American Standard Heating & Air Conditioning systems order a 120 VAC to 24 VAC transformer, KIT# BAYTRANS12024□ to provide 24 volt power only to the air cleaner. Access to 120 VAC outlet is required.

- Connect the power/control wiring per Figure 3.

NOTE: Trane/American Standard Heating & Air Conditioning Communicating Furnaces require KIT # BAYACCECOMM101.

NOTE: Wiring diagrams for the Communicating Air Handler, Communicating Furnaces and Oil Furnace are on pages 3, 4-5 and 6 respectively.

② Wiring Diagram Communicating Mode

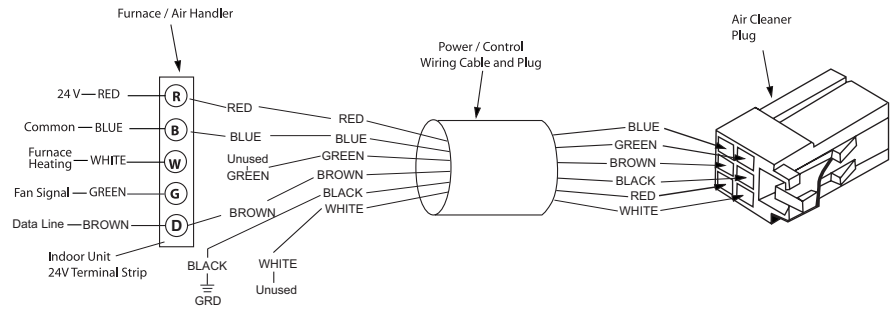

NOTE: The Black wire must be connected to chassis ground to ensure proper operation.

Air Handler may not have a Low Voltage Terminal board. Connect Electronic Air Cleaner wires to the Air Handler Low Voltage Color coded wires.

Install Transformer, one is supplied with the Electronic Air Cleaner, in the Furnace or Air Handler.

BAYTRANS12024♦ Transformer

- Transformer must have a grounded 120 VAC power source. Do not defeat ground plug on the transformer.
- Mount transformer to building structure with the four provided wood screws.

NOTE: BAYTRANS12024C complies with the California Code of Regulation, Title 20, Sections 1601 through 1608 dated December 2006. BAYTRANS12024A with vendor's manufacturing date codes after 0625 (YYWW) cannot be installed in California because the transformer does not satisfy the requirements set forth by California Code of Regulations, Title 20, Sections 1601 through 1608 dated December 2006.

Transformer not applicable to 50 Hz units.

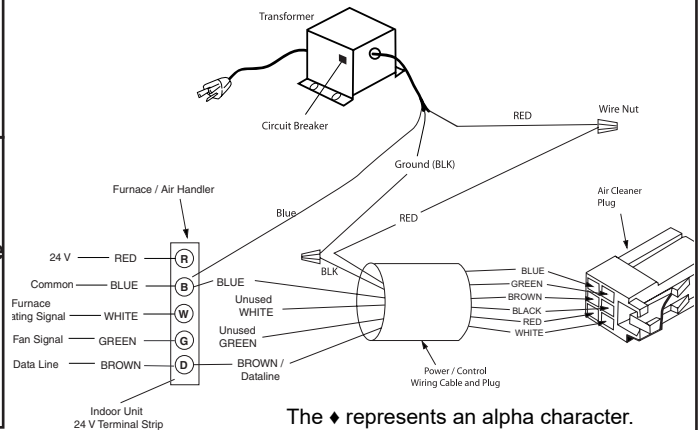

The ♦ represents an alpha character.

③ Wiring Diagram for 24 V Mode

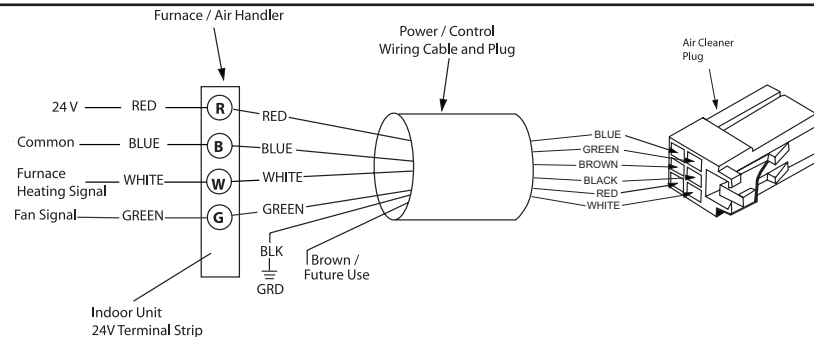

NOTE: The Black wire must be connected to chassis ground to ensure proper operation.

Air Handler may not have a Low Voltage Terminal board. Connect Electronic Air Cleaner wires to the Air Handler Low Voltage Color coded wires.

Install Transformer, one is supplied with the Electronic Air Cleaner, in the Furnace or Air Handler.

BAYTRANS12024♦ Transformer

- Transformer must have a grounded 120 VAC power source. Do not defeat ground plug on the transformer.
- Mount transformer to building structure with the four provided wood screws.

NOTE: BAYTRANS12024C complies with the California Code of Regulation, Title 20, Sections 1601 through 1608 dated December 2006. BAYTRANS12024A with vendor's manufacturing date codes after 0625 (YYWW) cannot be installed in California because the transformer does not satisfy the requirements set forth by California Code of Regulations, Title 20, Sections 1601 through 1608 dated December 2006.

Transformer not applicable to 50 Hz units.

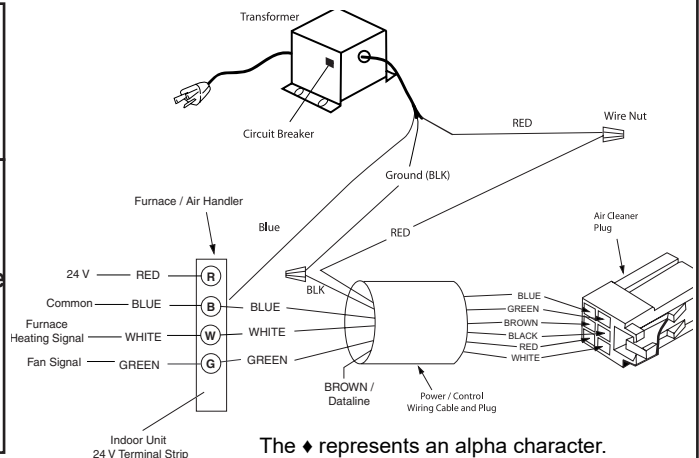

The ♦ represents an alpha character.

ELECTRICAL CONNECTIONS TO A COMMUNICATING SYSTEM AIR HANDLER IN CONVENTIONAL 24 V MODE

⚠ WARNING

HAZARDOUS VOLTAGE! DISCONNECT ALL ELECTRIC POWER, INCLUDING REMOTE DISCONNECTS BEFORE SERVICING. FOLLOW PROPER LOCKOUT/TAGOUT PROCEDURES TO ENSURE THE POWER CAN NOT BE INADVERTENTLY ENERGIZED. FAILURE TO DISCONNECT POWER BEFORE SERVICING COULD RESULT IN DEATH OR SERIOUS INJURY.

PROCEDURE:

- 1) Remove electrical power going into the air handler.
- 2) On the communicating systems air handler, remove the blower access panel.
- 3) Remove the communicating control box cover.
- 4) Locate the red jumper wire which is attached from EAC to R on the Communicating Systems PCB. Confirm it is connected. If there is not a jumper wire installed, then one must be installed in this location in order for the air cleaner to function properly.
- 5) Replace the Communicating control box cover.
- 6) Locate the white wire coming from the Communicating System Air Handler PCB labeled "EAC". The wire will have a male spade terminal connected to it and a female spade terminal inserted into the male terminal. Remove the female spade terminal and crimp it to the green wire on the air cleaner harness.
- 7) Connect the green wire from the air cleaner harness to the white wire on the Communicating Systems Air Handler.
- 8) Using the wire harness supplied with the air cleaner, connect the Red and Blue wires from the air cleaner harness to "R" and "B" on the Indoor Unit 24V Terminal Strip respectively.
- 9) Connect the Black wire from the air cleaner wire harness to earth ground by attaching the wire to a grounded screw that is connected to the metal air handler chassis.
- 10) Replace the blower access panel.
- 11) Reconnect electrical power to the air handler.

Detach female spade terminal from white EAC wire and crimp to green wire

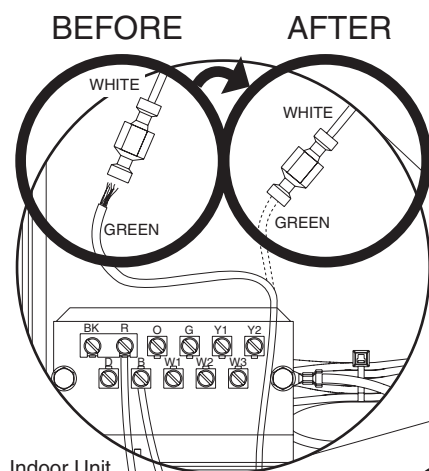

Indoor Unit
24V
Terminal
Strip Detail

Control box panel cover
(Shown removed)

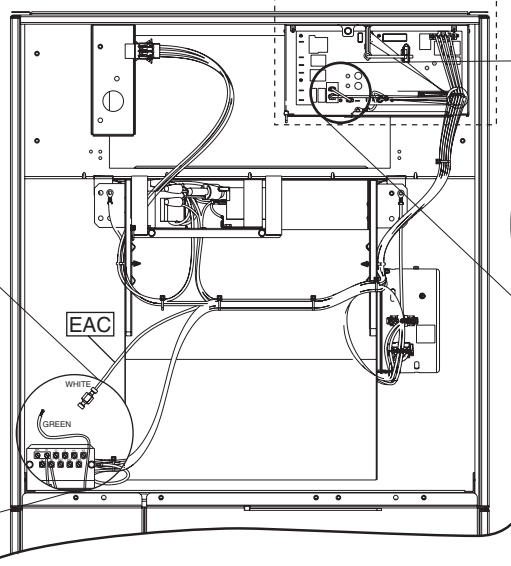

**24V RED
jumper wire
from EAC to R**

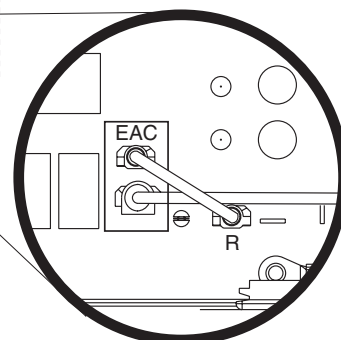

PCB Detail

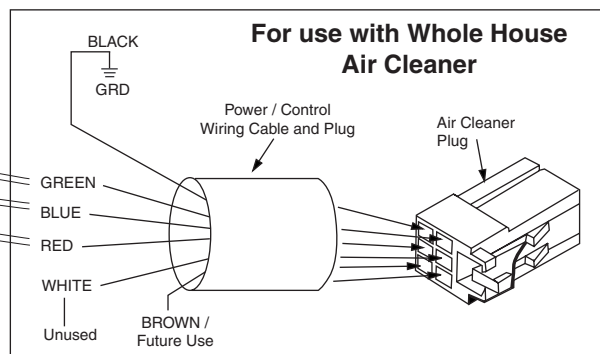

ELECTRICAL CONNECTIONS TO A STANDARD 24 VOLT AIR HANDLER

⚠ WARNING

HAZARDOUS VOLTAGE! DISCONNECT ALL ELECTRIC POWER, INCLUDING REMOTE DISCONNECTS BEFORE SERVICING. FOLLOW PROPER LOCKOUT/TAGOUT PROCEDURES TO ENSURE THE POWER CAN NOT BE INADVERTENTLY ENERGIZED. FAILURE TO DISCONNECT POWER BEFORE SERVICING COULD RESULT IN DEATH OR SERIOUS INJURY.

GAM5 / A/TAM4

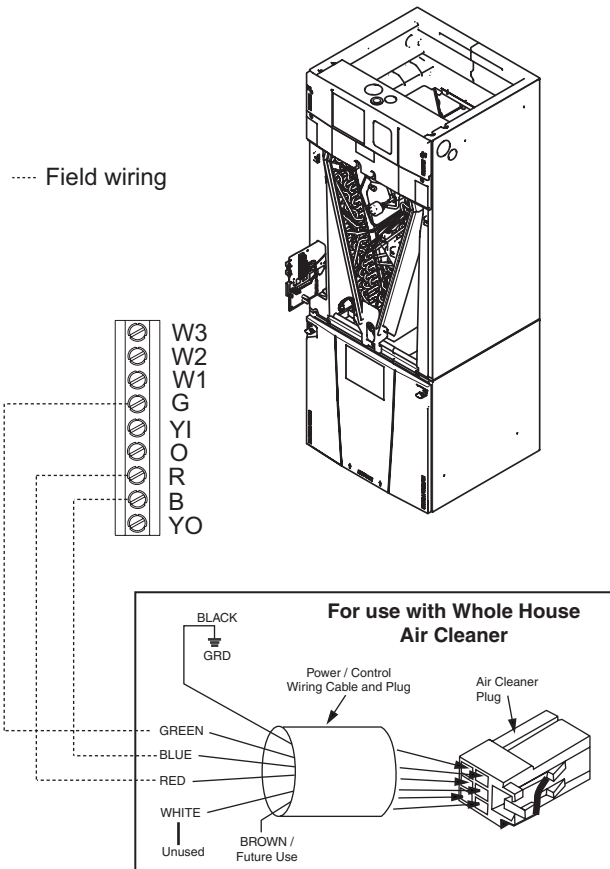

A/TAM7

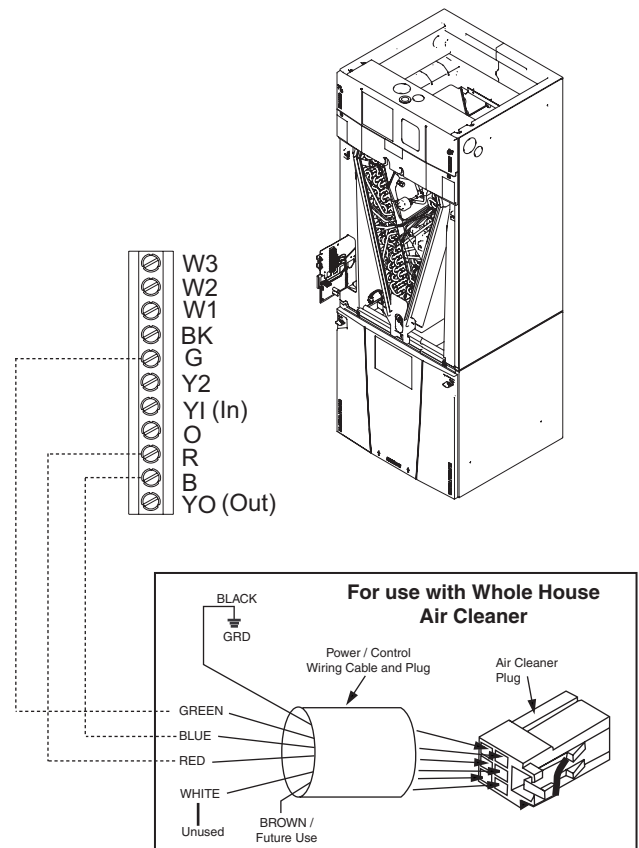

Service Facts

ELECTRICAL CONNECTIONS TO A COMMUNICATING SYSTEMS AIR HANDLER IN COMMUNICATING MODE

⚠ WARNING

HAZARDOUS VOLTAGE! DISCONNECT ALL ELECTRIC POWER, INCLUDING REMOTE DISCONNECTS BEFORE SERVICING. FOLLOW PROPER LOCKOUT/TAGOUT PROCEDURES TO ENSURE THE POWER CAN NOT BE INADVERTENTLY ENERGIZED. FAILURE TO DISCONNECT POWER BEFORE SERVICING COULD RESULT IN DEATH OR SERIOUS INJURY.

PROCEDURE:

- 1) Remove electrical power going into the air handler.
- 2) On the communicating systems air handler, remove the blower access panel.
- 3) Connect Red stripped wire to "R" terminal on the air handler terminal strip.
- 4) Connect Blue stripped wire to "B" terminal on the air handler terminal strip.
- 5) Connect the brown wire from the air cleaner harness to the "D" terminal on the Communicating Systems Air Handler.
- 6) Connect the Black wire from the air cleaner wire harness to earth ground by attaching the wire to a grounded screw that is connected to the metal air handler chassis or control plate assembly.
- 7) The Green and White wires on the air cleaner wiring harness are unused in this application and should be insulated separately.
- 8) Replace the blower access panel.
- 9) Reconnect electrical power to the air handler.
- 10) Check air cleaner and air handler operation.

4TEE3C

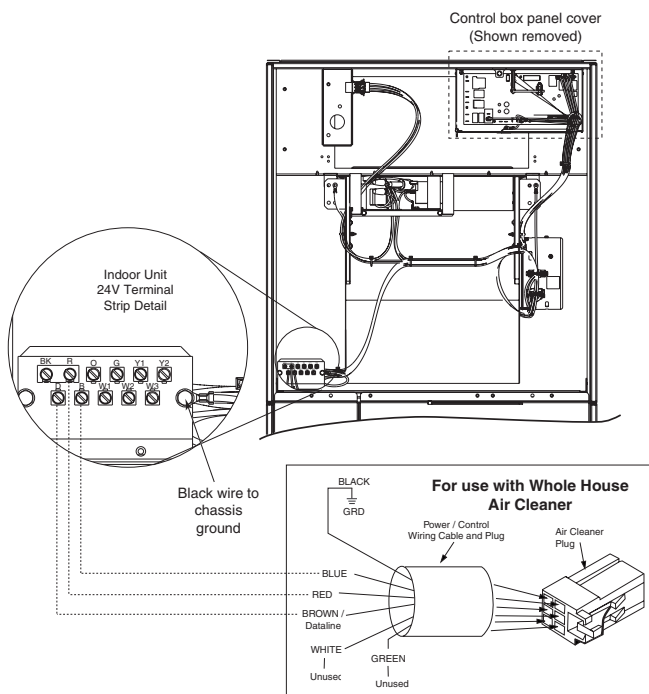

A/TAM8

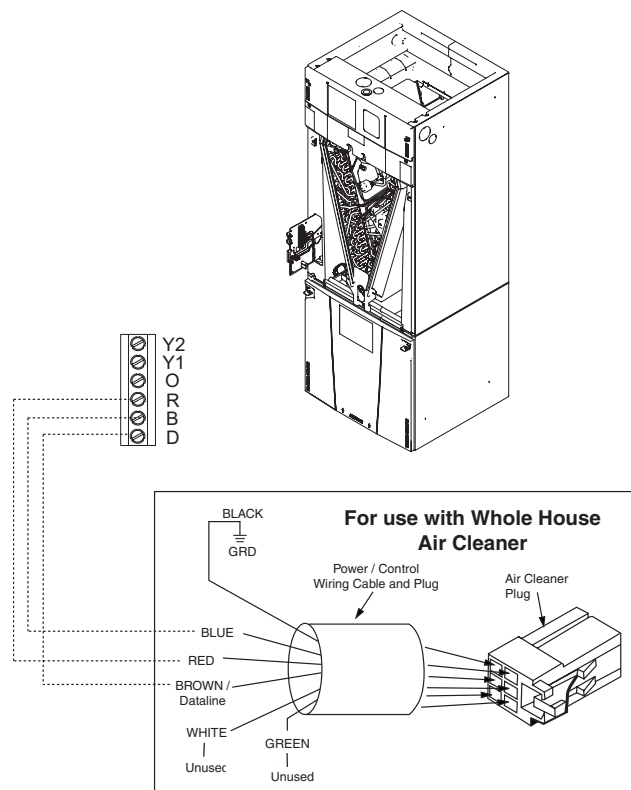

ELECTRICAL CONNECTIONS TO A COMMUNICATING FURNACE IN 24 V MODE

⚠ WARNING

HAZARDOUS VOLTAGE! DISCONNECT ALL ELECTRIC POWER, INCLUDING REMOTE DISCONNECTS BEFORE SERVICING. FOLLOW PROPER LOCKOUT/TAGOUT PROCEDURES TO ENSURE THE POWER CAN NOT BE INADVERTENTLY ENERGIZED. FAILURE TO DISCONNECT POWER BEFORE SERVICING COULD RESULT IN DEATH OR SERIOUS INJURY.

PROCEDURE:

1. Remove electrical power going into the furnace.
2. Remove blower door to up-flow or down-flow furnace.
3. Remove the two screws that secure the IFC platform to the underside of the blower deck on an up-flow furnace or the 3 screws that secure the IFC platform to the top panel on a down-flow furnace.
4. Carefully remove the IFC platform from the furnace.
5. On both the up-flow and down-flow furnaces, mount the 50VA transformer supplied in the packaging with the air cleaner onto the bottom of the IFC platform. Screws and pilot holes are provided. See figure.
6. Remove wiring from existing 35VA transformer and reconnect to the 50VA transformer. Note the polarity of the wires and reconnect to the appropriate terminals. See diagram
7. Remove the EAC-H 115VAC and EAC-N wires (white and black) out of the junction box and pull them through the grommet in the blower deck. Attach two supplied 1/4" insulated female quick connect terminals by stripping the wires and crimping the terminals onto the wires. Attach these wires to the 115V terminals of the 35VA transformer as shown in the diagram.
8. Remove the wiring harness supplied with the air cleaner from the packaging. Attach a supplied 3/16" insulated female quick connect terminal to the blue wire and the green wire.
9. Attach the blue wire from the air cleaner wiring harness to the open tab on the piggyback terminal supplied in the BAYACCE-COMM101. Attach piggyback terminal to the 35VA transformer terminal "C" (Common).
10. Insert the 12" blue stripped wire under the terminal strip screw marked "B/C" on the IFC control board. If the application also includes an outdoor unit (communicating or non-communicating), the B/C terminal will require 3 wires connected. For this connection, rather than connecting the three wires to the low voltage terminal strip on the furnace IFC, create a pigtail using a short length of thermostat wire and a wire nut (field supplied) to attach to the B/C terminal.
11. Connect the green wire from the air cleaner wiring harness to the 24V terminal on the 35VA transformer labeled "RD". See diagram.
12. Insert the red stripped wire from the air cleaner wiring harness under the IFC control board terminal screw marked "R". See diagram.
13. Attach the black stripped wire from the air cleaner wiring harness directly to ground with a screw on the furnace chassis. See diagram.
14. Once all of the connections have been completed, remount the IFC control platform into the furnace.
15. Secure any loose wiring with wire ties.
16. The brown and white wires from the EAC wiring harness are unused in this application and should be insulated. See diagram.
17. Replace the furnace door.
18. Reconnect electrical power to the furnace.
19. Check both furnace and air cleaner operation per the furnace and air cleaner installer guides.

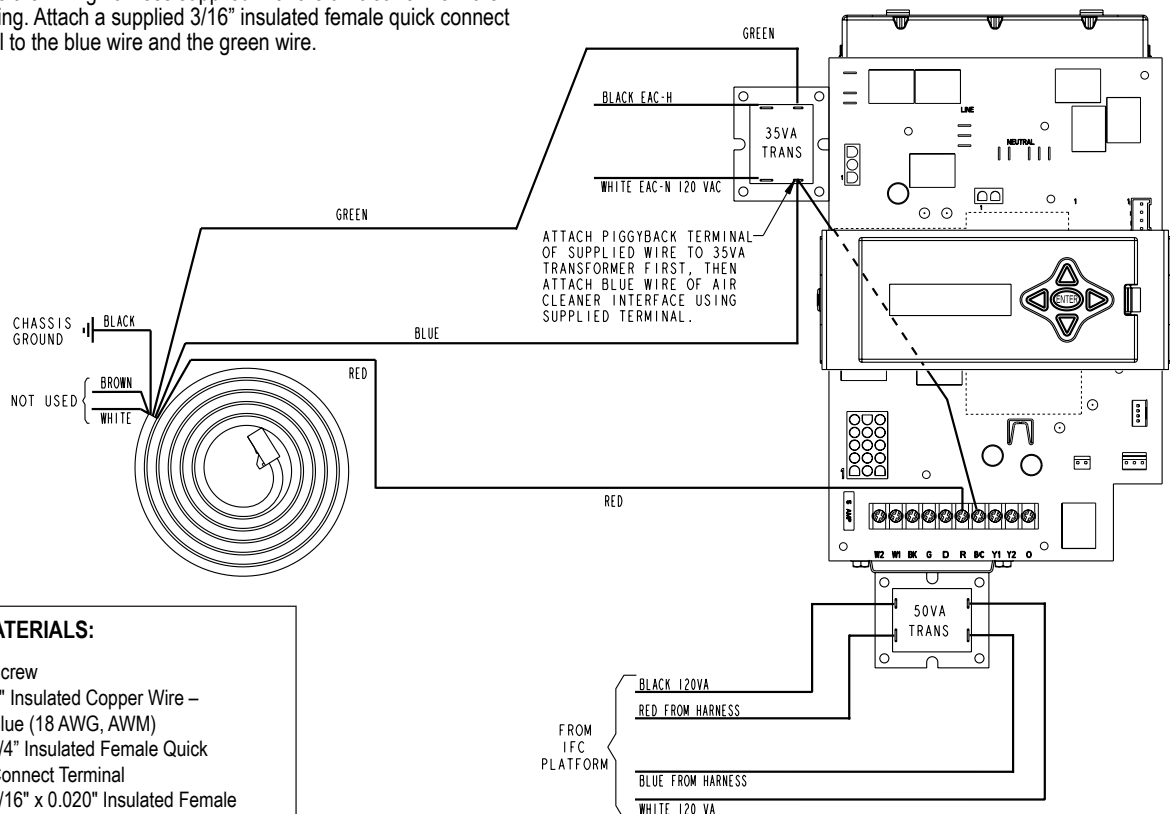

BILL OF MATERIALS:

QTY: 2	Screw
QTY: 1	4" Insulated Copper Wire – Blue (18 AWG, AWM)
QTY: 2	1/4" Insulated Female Quick Connect Terminal
QTY: 2	3/16" x 0.020" Insulated Female Quick Connect Terminal
QTY: 1	3/16" x 0.020" Receptacle & Tab

These instructions and listed parts are included in KIT# BAYACCECOMM101

ELECTRICAL CONNECTIONS TO A COMMUNICATING SYSTEM FURNACE

⚠ WARNING

HAZARDOUS VOLTAGE! DISCONNECT ALL ELECTRIC POWER, INCLUDING REMOTE DISCONNECTS BEFORE SERVICING. FOLLOW PROPER LOCKOUT/TAGOUT PROCEDURES TO ENSURE THE POWER CAN NOT BE INADVERTENTLY ENERGIZED. FAILURE TO DISCONNECT POWER BEFORE SERVICING COULD RESULT IN DEATH OR SERIOUS INJURY.

PROCEDURE:

1. Remove electrical power going into the furnace.
2. Open blower door to upflow or downflow furnace.
3. Disconnect all wires on the 35VA transformer.
4. Remove the 35VA transformer from the IFC platform.
5. Mount the 50 VA transformer supplied in the packaging with the air cleaner onto the IFC platform where the 35VA transformer was previously located. Use the sheet metal screws supplied with the air cleaner to mount the 50VA transformer. Reconnect the 115V and 24V wires that were connected to the 35VA transformer onto the 50 VA transformer.

6. Connect Red stripped wire to "R" terminal on the furnace control board.
7. Connect Blue stripped wire to "B" terminal on the furnace control board.
8. Connect Brown stripped wire to "D" terminal on the furnace control board.
9. Attach the black stripped wire from the air cleaner wiring harness directly to ground with a screw in the chassis.
10. The green and white wires on the air cleaning wiring harness are unused in this application and should be insulated.
11. Replace door on furnace.
12. Reconnect electrical power to the furnace.
13. Check both furnace and air cleaner operation per the furnace and air cleaner installer guides.

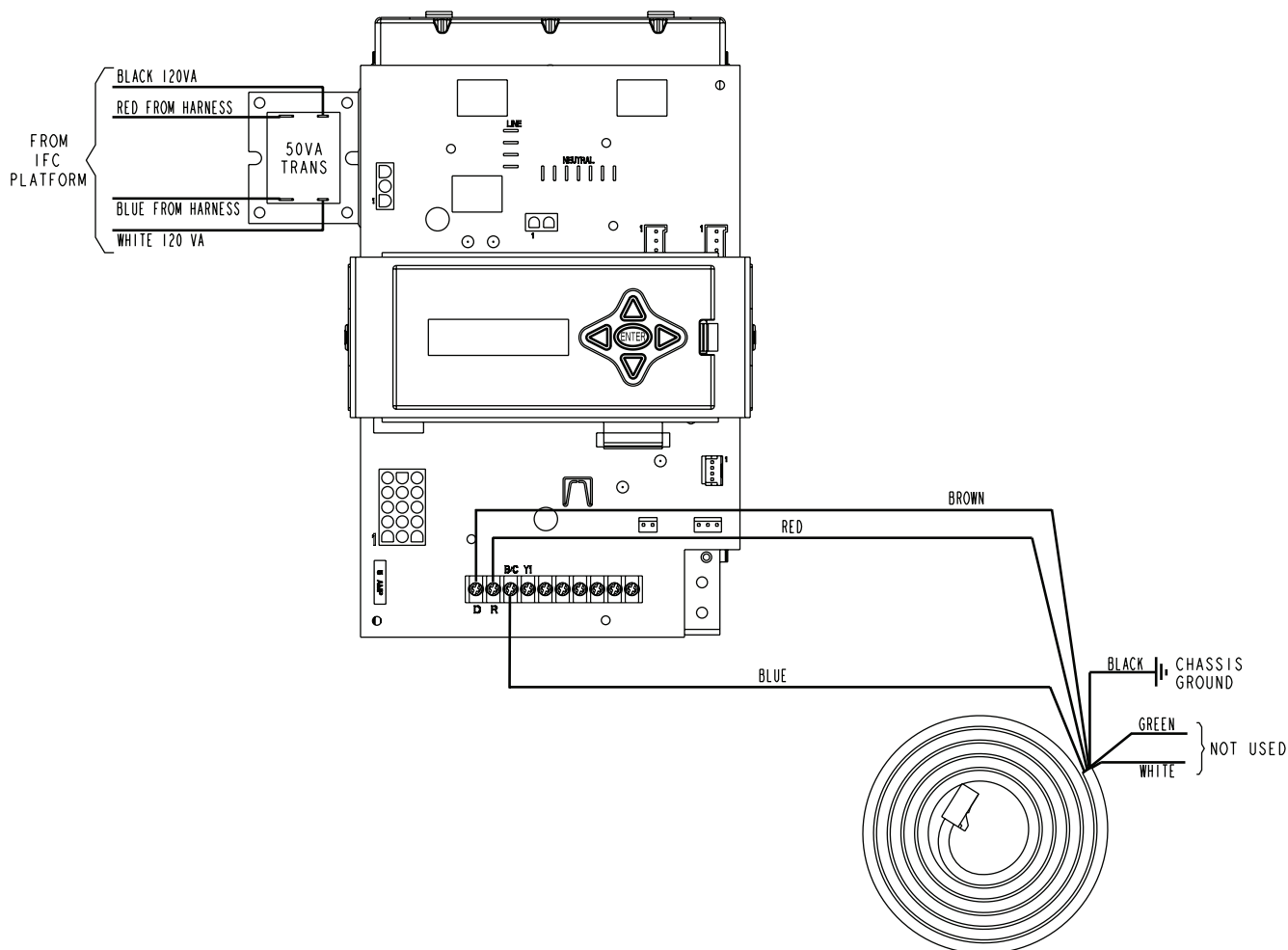

ELECTRICAL CONNECTIONS TO AN OIL FURNACE

⚠ WARNING

HAZARDOUS VOLTAGE! DISCONNECT ALL ELECTRIC POWER, INCLUDING REMOTE DISCONNECTS BEFORE SERVICING. FOLLOW PROPER LOCKOUT/TAGOUT PROCEDURES TO ENSURE THE POWER CAN NOT BE INADVERTENTLY ENERGIZED. FAILURE TO DISCONNECT POWER BEFORE SERVICING COULD RESULT IN DEATH OR SERIOUS INJURY.

Refer to the diagrams below for proper connections to an oil furnace. Consult the oil furnace installer's guide for additional information.

SINGLE STAGE OIL FURNACE TO AIR CLEANER

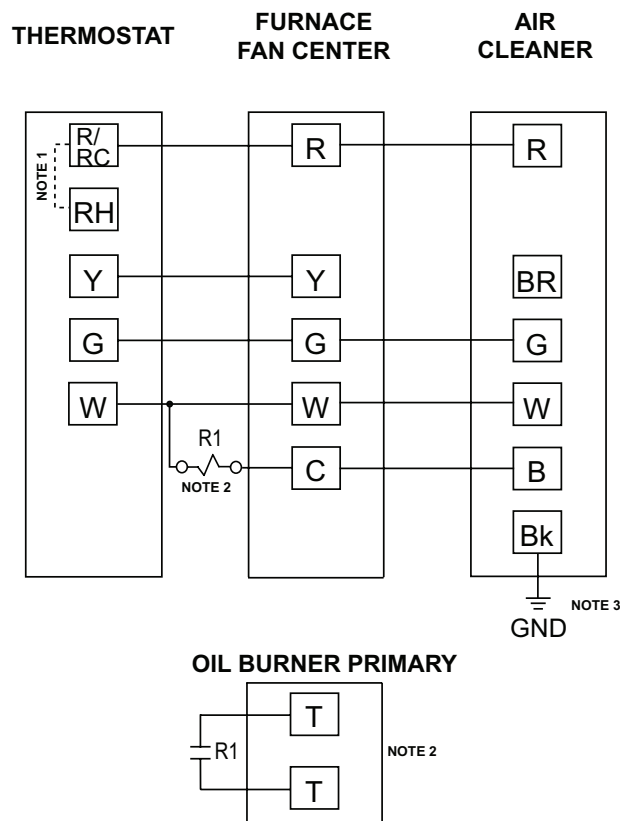

VARIABLE SPEED OIL FURNACE TO AIR CLEANER

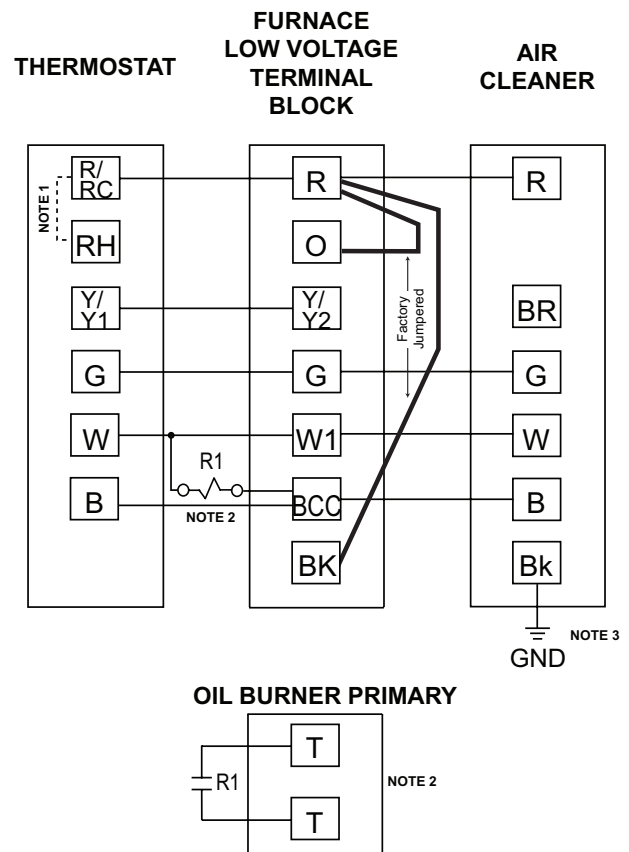

ELECTRICAL CONNECTIONS FOR DUAL WHOLE HOUSE AIR CLEANER

Dual Whole House Air Cleaners

In some instances, two whole house air cleaners can be utilized to manage the overall system operational static pressure. The figure below shows two whole house air cleaners installed on an upflow furnace. The 24 volt transformer which supplies power to the air cleaner will need to be increased by 25 VA for each additional air cleaner added.

See the wiring diagrams for information on how to attach the wires in a two whole house air cleaner system. The figure on the top of page 10 shows the wiring hookup for two whole house air cleaners attached to a furnace in conventional 24 V mode.

The figure on the bottom of page 10 shows the wiring hookup for two whole house air cleaners attached to a furnace in communicating mode.

Refer to the wiring diagrams on pages 3 through 8 for guidance on wiring the whole house air cleaners to the system properly. All wires will be run the same way for each of the two whole house air cleaners.

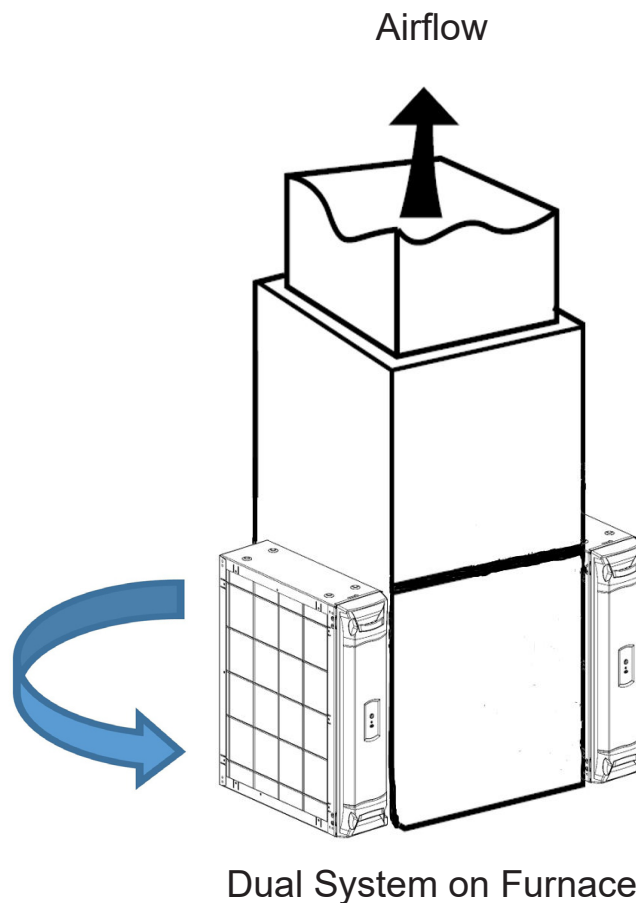

ELECTRICAL CONNECTIONS FOR DUAL WHOLE HOUSE AIR CLEANERS AND FURNACE IN CONVENTIONAL 24V MODE

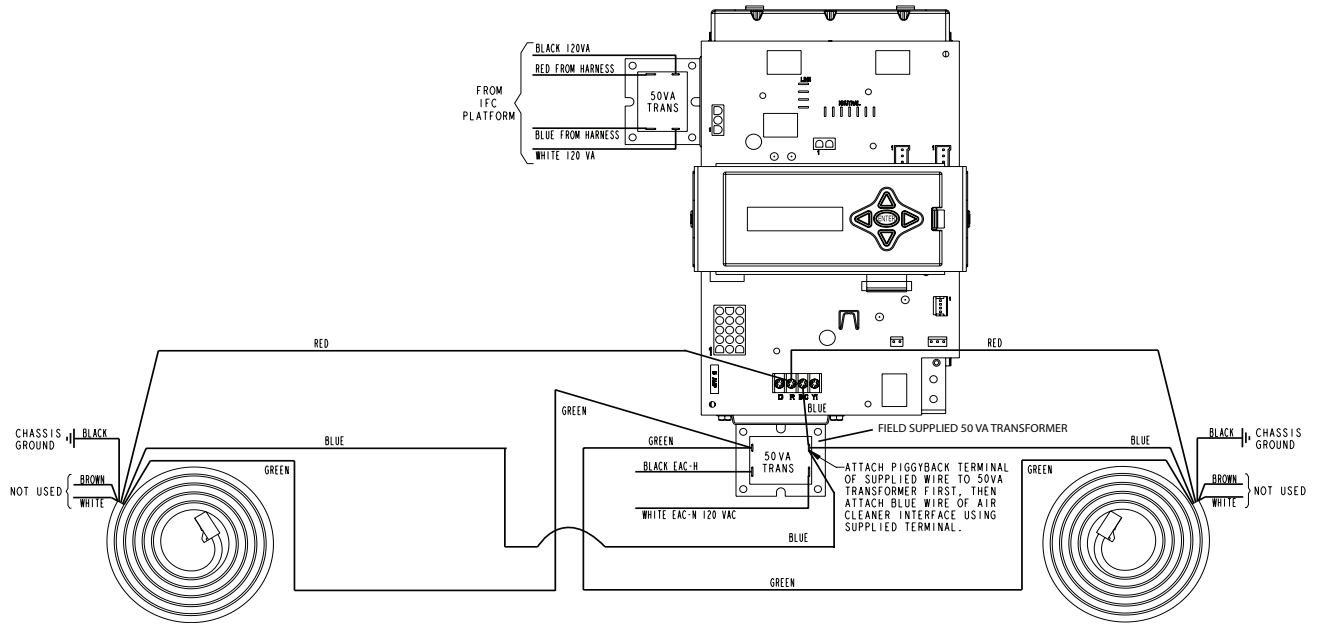

ELECTRICAL CONNECTIONS FOR DUAL WHOLE HOUSE AIR CLEANER AND FURNACE IN COMMUNICATING MODE

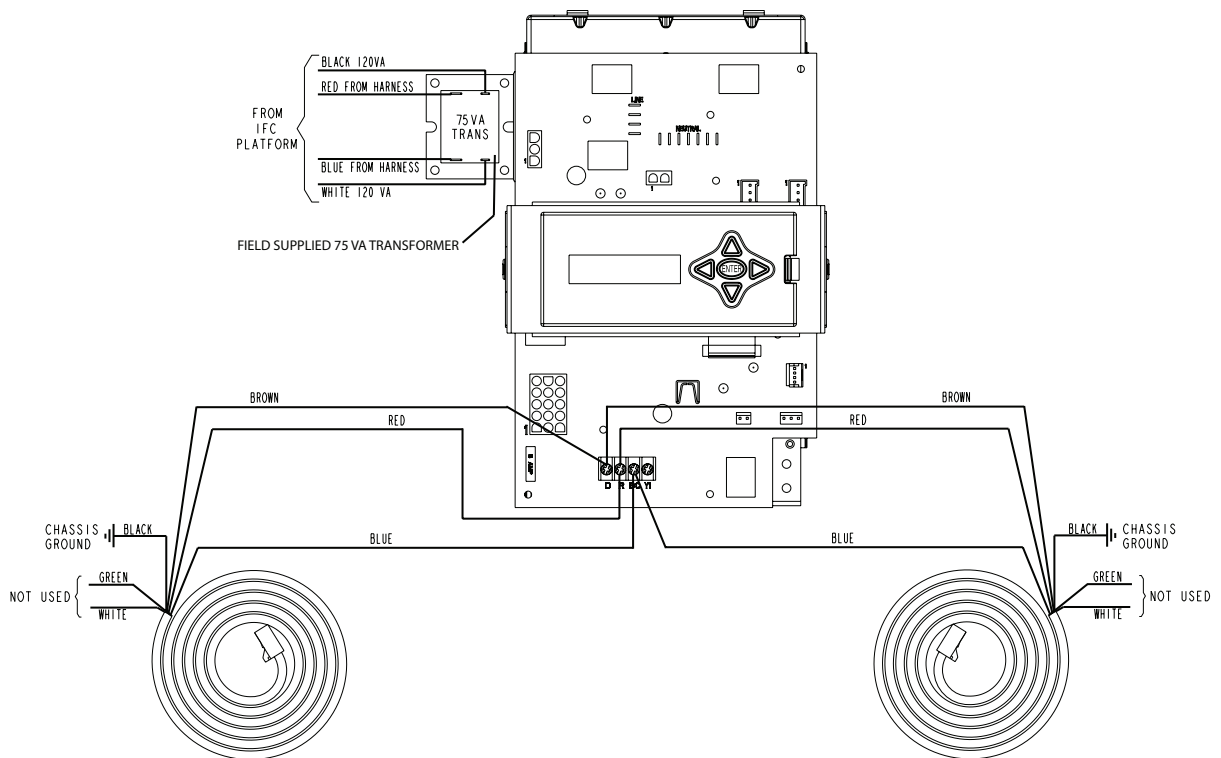

Service Facts

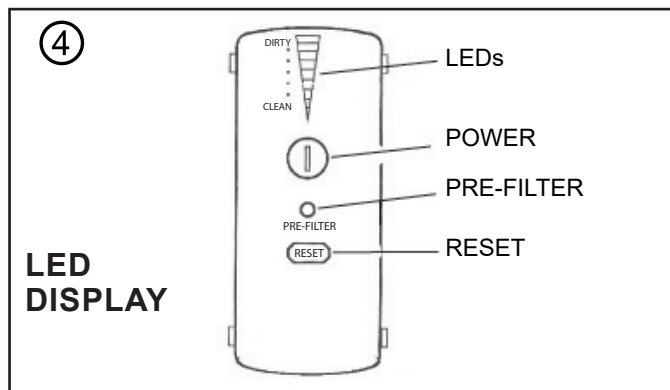

DISPLAY FEATURES (Fig. 4)

The Air Cleaner display can be used for several functions.

- Provide the homeowner the operating status of the air cleaner, including an indication the PRE-FILTER or COLLECTION CELLS need cleaning.
- The installer can access the SET-UP mode to change the time to clean settings for the PRE-FILTER and COLLECTION CELLS as well as change the Power level setting.
- The unit will display fault codes for the homeowner indicating there is a problem with the Air Cleaner and various fault codes for the service technician to assist in troubleshooting the problem.

AIR CLEANER OPERATION

Turn the Air Cleaner on by pushing and releasing the POWER button. The backlit POWER and RESET buttons will illuminate along with the first Green LED (G1) indicating 24 volt power is present to the Air Cleaner.

When the indoor fan is operating the first LED (G1) will slowly flash. This indicates the FIELD CHARGER and COLLECTION CELLS have power and the unit is operating normally. There is a slight time delay between the indoor fan starting and LED (G1) flashing. Time delay for "G" fan is 10 [12] seconds. Time delay for heating is 90 [108] seconds.

In normal operation, the Air Cleaner makes a slight sound as the air passes through it and is cleaned. In some applications, you may notice this sound coming from the return air vent(s). If desired, this sound level can be reduced with minimal impact on air cleaning efficiency by reducing the power setting of the FIELD CHARGER in the SET-UP mode.

NOTE: There is a 10 [12] minute delay after the indoor fan operates, before the Air Cleaner starts to operate, each time the power to the Air Cleaner is turned off/on. This can be bypassed by going into and then out of the SET-UP mode

SET-UP MODE

A combination of Red, Yellow, and Green LED's are used to indicate the following settings.

- Three Green LED's are used to indicate PRE-FILTER cleaning interval. This is measured in actual run time of the indoor fan. The factory setting is 2 months [10 weeks]. Figure 5.
- Four Yellow LED's indicate the COLLECTION CELL cleaning interval. This is measured in actual run time of the indoor fan. The factory setting is 6 months [31 weeks]. See Figure 6.
- The three Red LED's indicate the power level setting. The default setting is maximum. See Figure 7.

SET-UP MODE OF OPERATION

To enter the SET-UP mode press and hold both the POWER and RESET buttons for a minimum of 5 [6] seconds. The display will go blank and then the factory settings for each of the settings are displayed. If this is the desired setting or at any time you want to exit the SET-UP mode, press and hold BOTH the POWER and filter RESET buttons for a minimum of 5 [6] seconds to exit.

To change any of the settings, press the POWER button once. Follow the below instructions for setting the pre-filter and collection cell timers. For a Communicating Air Cleaner, be sure the Comfort Control filter timer is set to "Auto Detect" before changing the settings on the air cleaner. To determine whether or not the unit is a communicating unit, review the Amber light shown in Figure 1a on page 2.

PRE-FILTER SETTING (Fig.5)

One or more of the Green LED's will come on indicating the PRE-FILTER cleaning time setting. Repeatedly press the RESET button to cycle through the time options for the PRE-FILTER cleaning cycle until the desired setting is displayed. Press the POWER button once to accept that setting and move to the COLLECTION CELLS cleaning settings.

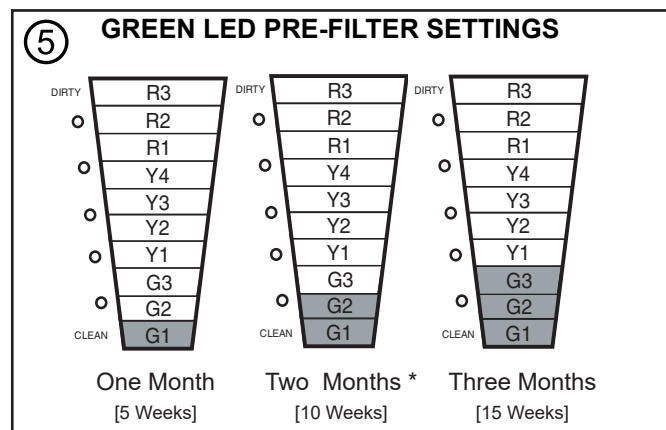

COLLECTION CELLS CLEANING SETTING (Fig.6)

One or more of the Yellow LED's will come on indicating the COLLECTION CELLS cleaning time setting. Repeatedly press the RESET button to cycle through the time options for the COLLECTION CELLS cleaning cycle until the desired setting is displayed. Press the POWER button once to accept that setting and move to the Power level settings.

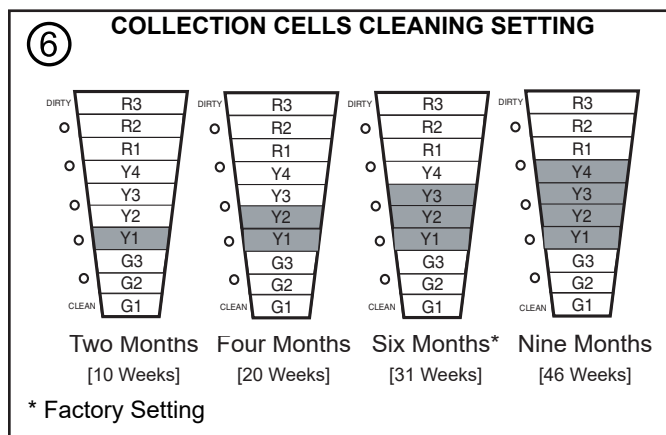

NOTE: If two air cleaners are connected on the same system, set all timers on both air cleaners to the same settings. The comfort control will only report one air cleaner timer and this methodology will allow the air cleaners to remain on the same cleaning schedule.

FIELD CHARGER Power Level

The Red LED lights are used to set the power level of the FIELD CHARGER for maximum, medium, or minimum. The number of illuminated Red LED lights indicates the current setting. The factory setting is for maximum.

Lower settings will reduce the slight sound emitted by the unit with minimal loss of air cleaning efficiency, if desired. Lower settings will also further reduce the very low ozone produced by the Air Cleaner.

FIELD CHARGER Power Level Setting (Fig. 7)

One or more of the Red LED lights will illuminate. To change the power level setting, press the RESET button until the desired setting is indicated.

To save your new settings and exit the SET-UP mode, press and hold BOTH the POWER and filter RESET buttons for a minimum of 5 [6] seconds.

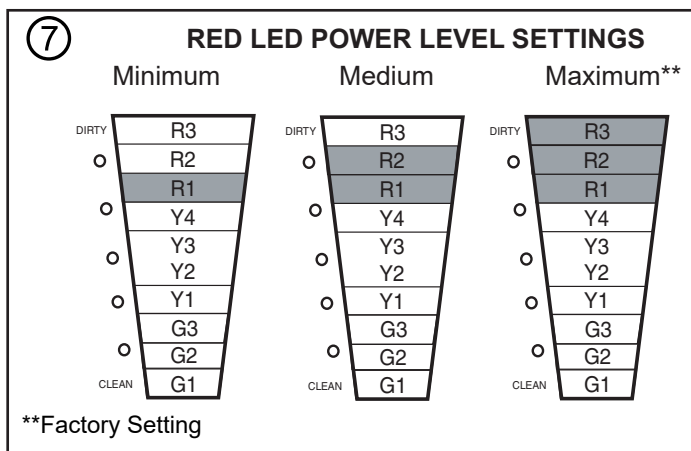

FAULT CODES

The Air Cleaner LEDs will display a fault indication, three yellow or three Red LEDs, when a fault has been detected. A log of the last three faults is recorded and can be accessed by going into the SET-UP mode. The unit will repetitively check the system to determine if the fault persists. The fault indication will be displayed as long as the fault condition remains.

If the fault is no longer present, the system will return to normal operation and no longer display the fault indication. Even if the fault has been corrected, a log of the last 3 faults is recorded.

THREE YELLOW LEDs FLASHING

These LEDs flashing on and off means that the PRE-FILTER or the COLLECTION CELLS need to be cleaned. The Air Cleaner control has detected ten consecutive automatic High Voltage Shut Down (HVSD) cycles. An automatic HVSD cycle is normally activated by the control system when an internal electrical arc occurs.

THREE RED LEDs & THE PRE-FILTER LED FLASHING

This means service is needed. For these THREE Red LEDs to flash on and off the control must have detected the SAME FAULT (see Fault Code Table on page 5) THREE TIMES in a row. The PRE-FILTER will flash during the 3 flashing Yellow LEDs or 3 flashing Red LEDs lockout mode.

FAULT CODES RETRIEVAL

To retrieve the last three faults that the Air Cleaner Control has detected, enter the SET-UP mode of operation.

Press and hold the POWER button and the RESET button for a minimum of five seconds. When the control enters the SET-UP mode of operation some of the Green, Yellow and Red LEDs will be on. The color and number of LEDs that are on indicates how the control is presently programmed. (See SET-UP CHARTS on previous page). To enter the Fault Codes section press and hold the RESET Button for ten seconds. After ten seconds the main LED display will go out for one second and then some of the LEDs may begin to flash on and off. If no fault has been detected then only the first Green LED will be flashing on and off. The flashing Green LED or LEDs identifies the fault number being reported out. One Green Led flashing on and off means the last fault detected is being reported out, two Green LEDs flashing means the second fault detected is being reported out and three Green LEDs flashing means the last fault stored in the control memory is being reported out. The last three faults detected will be stored in the control's memory and the last fault detected will be the first fault reported out.

You are now in the Fault Log report section and the last fault detected is now being reported out. To step through the faults, press the POWER button again to get the second fault and again pressing the POWER button will take you to the last fault stored in the control's memory. Push the POWER button again and the control will display the last fault detected. To exit the SET-UP mode, press and hold both the POWER and Filter RESET buttons for a minimum of 5 seconds.

FAULT CODES

When a fault is being reported out check the position number of any of the Yellow and Red LEDs flashing on and off. Compare this combination of flashing LEDs position numbers to the Fault Code chart to see which fault has been detected. The number one Yellow LED will always be out in the Fault Code report section.

Dual Air Cleaner Faults and Filter Reset:

When dual air cleaners are installed as part of a communicating system, each whole house air cleaner will retain its own faults. However, in a communicating system with dual air cleaners, the 900 series comfort control will only recognize the filter timers for one air cleaner. Both the Pre-Filter and Collection Cell timers for one air cleaner can be reset at the comfort control.

Service Facts

ifD™ DISPLAY FAULT LED CODES										
COMFORT CONTROL ERROR CODE	FAULT DESCRIPTION	YEL-1	YEL-2	YEL-3	YEL-4	RED-1	RED-2	RED-3	AIR-CLEANER COM LED	SERVICE PROCEDURE
18	Internal control lockout		ON	ON	ON	ON	OFF	OFF	Device Count	Repower Air Cleaner - check for normal operation. Replace door if same fault comes
37	Duplicate Filter, Another filter timer is present/ Only seen when Air Cleaner is configured in the communication mode and the Comfort Control filter times are not set to "E" auto-discover on set-up 500 and 501.		Not reported to air-cleaner user interface	Not reported to air-cleaner user interface	Not reported to air-cleaner user interface	Not reported to air-cleaner user interface	Not reported to air-cleaner user interface	Not reported to air-cleaner user interface	Device Count	User set-ups 500 and 501 will need to be changed back to "E" to enable the comfort control to auto-discover the filter cleaning timer set-up in the air-cleaner.
64	One or more buttons are stuck in the ON position on the air-cleaner door.		ON	ON	ON	ON	ON	OFF	Device Count	Check to see if buttons operate smoothly and are not obstructed. If unable to free button replace air-cleaner door
91	Communication Fault		ON	OFF	ON	OFF	OFF	ON	Device Count	Air-cleaner can not generate a ERROR CODE 91 on the comfort control, fault is with other unit.
No ERR Code	Communication Fault		ON	OFF	ON	OFF	OFF	ON	Fast Flash	Active communicating fault. Check for 12-13 voltage DC between Brown and Blue wires at the air-cleaner connection plug.
No ERR Code	Communication Fault		ON	OFF	ON	OFF	OFF	ON	Device Count	Like the furnace and air-handler's users interfaces the air-cleaner stores fault codes. Check air-cleaner COM LED for device count (one blink for each communicating device on the COM BUS) If device count is present ensure air-cleaner green LED #1 blinks slow with indoor blower operation. Clear fault log
107	Repetitive Arcing		ON	ON	ON	OFF	OFF	OFF	Device Count	Clean Collection Cells and Field Charger - If they are clean, check for arcing through the plastic frame.
108	HV off when it should be on / This can be caused by a grounded field charger or shorted cells which causes an air-cleaner shuts down before the power output reaches 5 KV.		ON	OFF	OFF	ON	OFF	OFF	Device Count	Check for arcing through the Collection Cells and Field Charger cases. Check door operation by referring to Testing the Power Door on page 17 of the air-cleaner's Service Facts
108	HV too LOW		ON	OFF	OFF	ON	ON	OFF	Device Count	Remove power door and recheck high voltage-if still low replace power door, if voltage is correct, check cells and Field Charger.
108	HV too HIGH		ON	OFF	OFF	ON	ON	ON	Device Count	Check for arcing through the Collection Cells and Field Charger cases. Check door operation by referring to Testing the Power Door on page 17 of the air-cleaner's Service Facts
109	Input Current too LOW		ON	ON	OFF	ON	ON	OFF	Device Count	Check Collection Cells and Field Charger connector pins.
109	Input Current too HIGH		ON	ON	OFF	ON	ON	ON	Device Count	Clean Collection Cells and Field Charger. Check for arcing through the Collection Cells and Field Charger cases.
125	Input A/C Voltage too LOW		OFF	OFF	OFF	ON	OFF	OFF		Check 24 volt supply to the air-cleaner. The supply voltage should not drop below 22 volts under full load. Ensure Transformer is rated for at least 50VA for furnaces and 75 for air-handlers. If two or more air-cleaners are connected on a system, ensure the transformer rating is increased 25 VA for each additional air-cleaner

NOTE: If more than one whole house air cleaner is installed, each unit will retain its own fault codes.

Examples: see Fig. 8

Ex. #1: The most recent fault condition was a High Voltage "HV was Low"

Ex. #2: The second fault condition was "Internal Control Lock-out"

Ex. #3: The third fault condition was "Input Current too High"

To clear all three faults codes from the control's memory, press and hold the RESET button for 2-4 seconds when the fault codes are displayed. When the fault memory is cleared, the Yellow and Red LEDs will go out for all three fault locations. The Green LED or LEDs will remain on to mark the fault number, first, second or third fault.

⚠ WARNING

High Voltage is present within the Air Cleaner for operation. Before removing the Power Door, turn the power off and wait at least 15 seconds to allow voltage to discharge. Failure to disconnect power before servicing could result in death or serious injury.

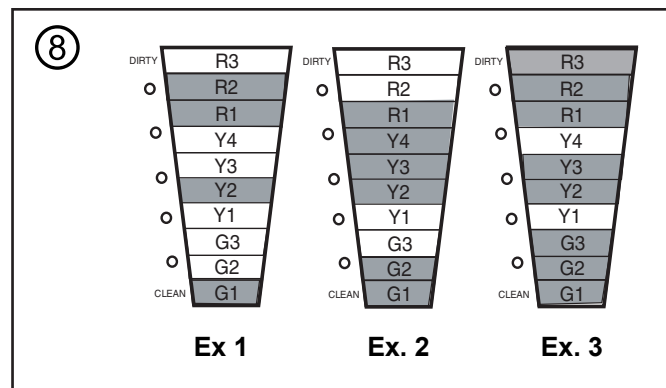

⚠ WARNING

RISK OF ELECTRIC SHOCK: These servicing instructions are for use by qualified personnel only. To reduce the risk of electric shock, do not perform any servicing other than that contained in the Service Facts unless you are qualified to do so. Failure to follow all electrical safety precautions could result in death or serious injury.

SYSTEM INFORMATION

⚠ CAUTION

Before cleaning the coil or ducts in the air handler or furnace, remove the **COLLECTION CELLS**, **FIELD CHARGER**, and **PRE-FILTER** from the Air Cleaner. Chemicals used during the cleaning of the air handler, furnace, or ductwork can damage the Air Cleaner components and degrade the performance of the Air Cleaner.

CLEANING

NOTE: When the air cleaner is installed in 24 V mode, the LED's on the front of the air cleaner door will indicate when it is time to clean the filters.

When the air cleaner is installed in communicating mode, the LED's on the front of the air cleaner will indicate when it is time to clean the air filters. In addition, the comfort control will also indicate when it is time to clean the filters.

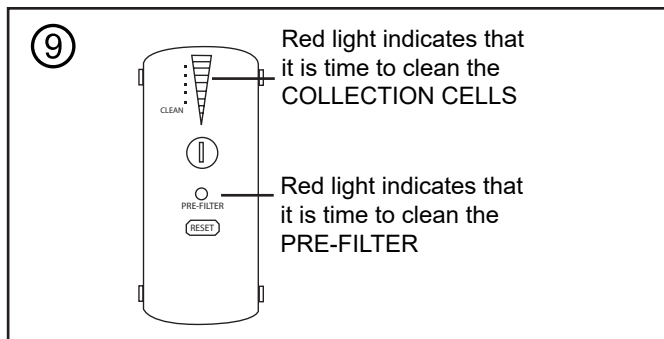

Cleaning Instructions:

The Air Cleaner utilizes a **PRE-FILTER** and **COLLECTION CELLS**. The purpose of the **PRE-FILTER** is to capture large particles before they enter the **COLLECTION CELLS** which allows the Collection Cells to work more efficiently.

1. Turn the air conditioning system off at the Comfort Control (thermostat).

⚠ WARNING

High Voltage is present within the Air Cleaner for operation. Before removing the Power Door, turn the power off and wait at least 15 seconds to allow voltage to discharge. Failure to follow all electrical safety precautions could result in death or serious injury.

2. Turn off power to the Air Cleaner by pushing and holding the **POWER** button for three seconds. The LEDs will remain on until the voltage has discharged and it is safe to remove the door. This requires approximately 15 seconds.

Do not remove the door until all of the lights are off.

3. Disconnect the power /control cable.
4. Remove the Door Assembly from Whole Home Air Cleaner by pulling away from the unit assembly. Place on the flat and clean working surface with interior components facing up. See Figure 10.

⚠ CAUTION

Handle the door only by using the handles on the front of the door. Grasp the door by the handles as depicted in Figure 10 to remove and replace the door. Do not handle the door on the edges. Metal edges may be sharp and could result in injury if the door is not handled properly.

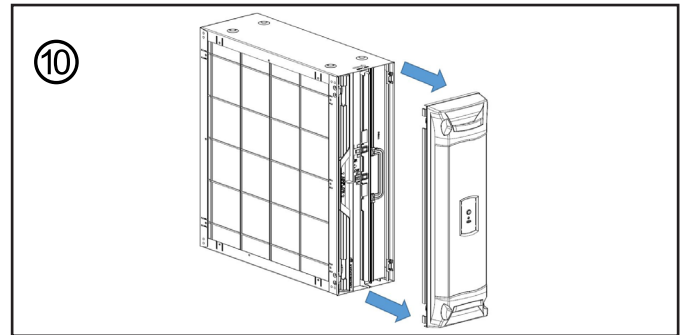

5. Remove the **PRE-FILTER** (Figure 11) and/or the **COLLECTION CELLS** (Figure 12) from the Air Cleaner.

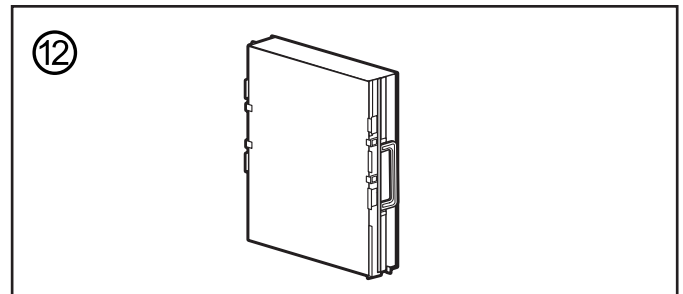
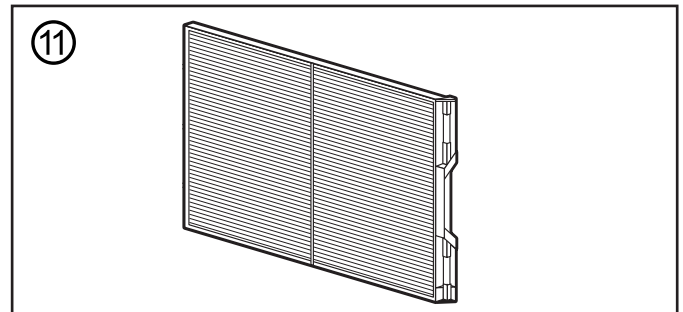

VACUUM CLEANING

Vacuuming is the preferred method to clean the **PRE-FILTER** and **COLLECTION CELLS**. It is recommended that the **PRE-FILTER** and the **COLLECTION CELLS** be vacuumed outside the home to ensure particles on the filters are not reintroduced into the air. Persons highly sensitive to the collected particles should wear appropriate respiratory protection while cleaning.

PRE-FILTER –

It is time to clean the **PRE-FILTER** when the red “**PRE-FILTER**” light is illuminated.

Service Facts

The Air Cleaner is factory set to notify the homeowner to clean the PRE-FILTER every two months [10 weeks] of actual run time of the Air Cleaner. This notification can be changed by the installer/homeowner to 1 month [5 weeks] or 3 months [15 weeks] depending on the conditions in the home (pets, smokers, etc.). Please see "SET-UP MODE" (page 3) to change the factory settings.

1. Using a vacuum hose, vacuum in even strokes across the entire PRE-FILTER. Vacuum using even strokes in one direction, then repeat the process using even strokes in the opposite direction as demonstrated in Figure 13 below.

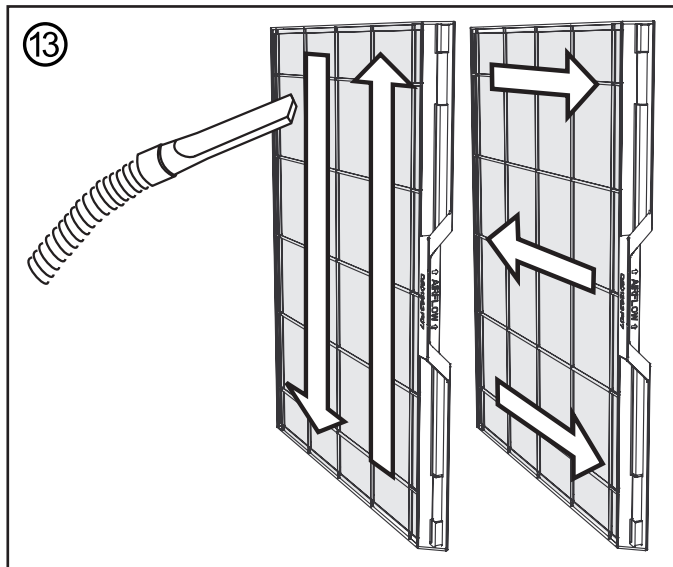

NOTE: Do NOT replace the plastic PRE-FILTER with a metal type PRE-FILTER. A metal PRE-FILTER will cause reduction in efficiency and potential failure of the electronics in the Air Cleaner.

COLLECTION CELLS

The clean/dirty LED light bar indicator will illuminate as the system cleans the air. The LED lights will progress from green to yellow and then to red. When the last red indicator is flashing, it is time to clean the COLLECTION CELLS (see Figure 12). The Air Cleaner is factory set to notify the homeowner to clean the COLLECTION CELLS every six months [31 weeks] of actual run time of the Air Cleaner. This notification can be changed by the installer/homeowner to 2 months, 4 months, 6 months, or 9 months [10, 20, 31, or 46 weeks] depending on the conditions in the home (pets, smokers, etc.). Please see "SET-UP MODE" (page 3) to change the factory settings.

1. Using a vacuum hose, vacuum in even strokes across the entire COLLECTION CELLS. Vacuum using even strokes in one direction, then repeat the process using even strokes in the opposite direction, as demonstrated in Figure 14.

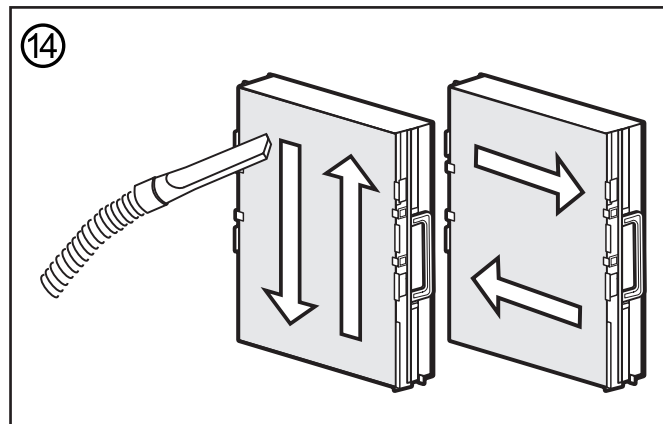

2. Once vacuuming is completed on one side of the COLLECTION CELLS, turn the COLLECTION CELLS over and repeat on the other side of the COLLECTION CELLS.

NOTE: It is normal for COLLECTION CELLS to discolor during operation. Vacuuming will not restore the COLLECTION CELLS to their original color. However, vacuuming does restore the COLLECTION CELLS to a high efficiency.

REPLACING THE PRE-FILTER AND COLLECTION CELLS INTO THE AIR CLEANER

1. Replace the PRE-FILTER into the Air Cleaner. Ensure that the "Air Flow indicator arrow" on the PRE-FILTER is pointing in the same direction as the "Air Flow indicator arrow" on the Air Cleaner cabinet.

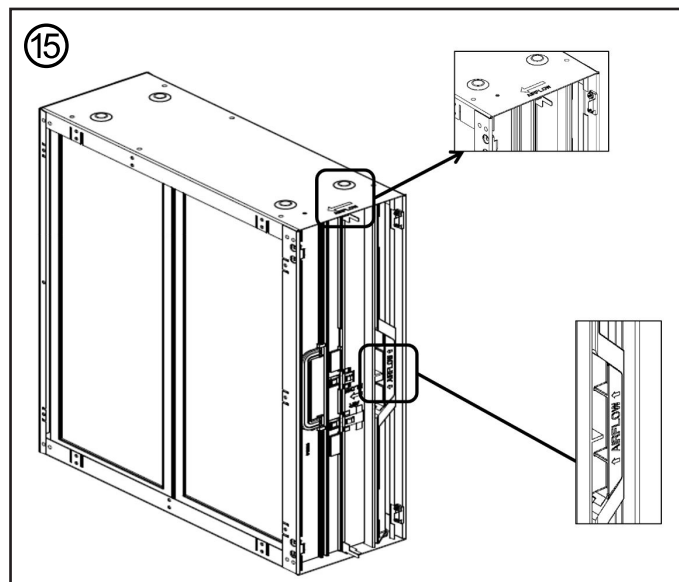

2. Reinstall the COLLECTION CELLS into the Air Cleaner. Ensure the handles on both of the COLLECTION CELLS are folded flat. Refer to Figure 16.

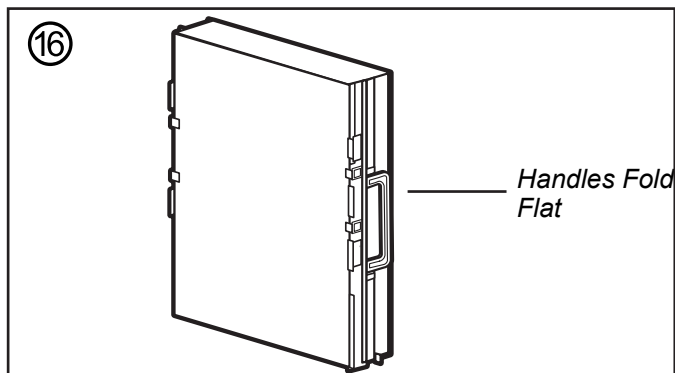

3. Replace the power door onto the Air Cleaner.
4. Ensure the power cord is plugged into the Air Cleaner.

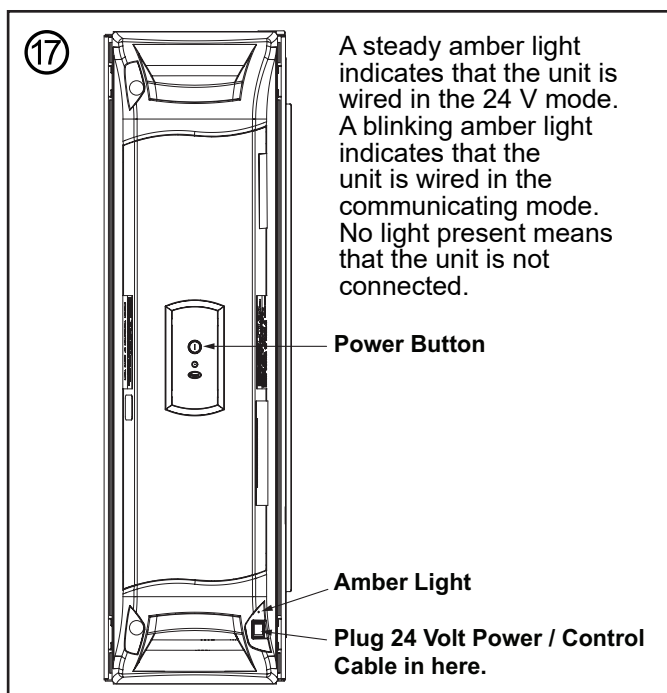

5. Press the POWER  button to turn on the Air Cleaner.

NOTE: Once you press the POWER button, the first LED will be on and it will start flashing after the first 10 [12] minutes of indoor fan operation. This is normal operation.

Alternate Cleaning Option For Homeowners with 200 or 200-1 COLLECTION CELLS ONLY

Vacuuming the PRE-FILTER and COLLECTION CELLS restores them to a high efficiency. However, some environmental conditions, like tobacco smoke, cause the COLLECTION CELLS to need to be washed with water. Washing the COLLECTION CELLS is acceptable ONLY if the COLLECTION CELLS have a "200/200-1" embossed or written on the frame in the vicinity of the manufacturing part number (Fig. 18).

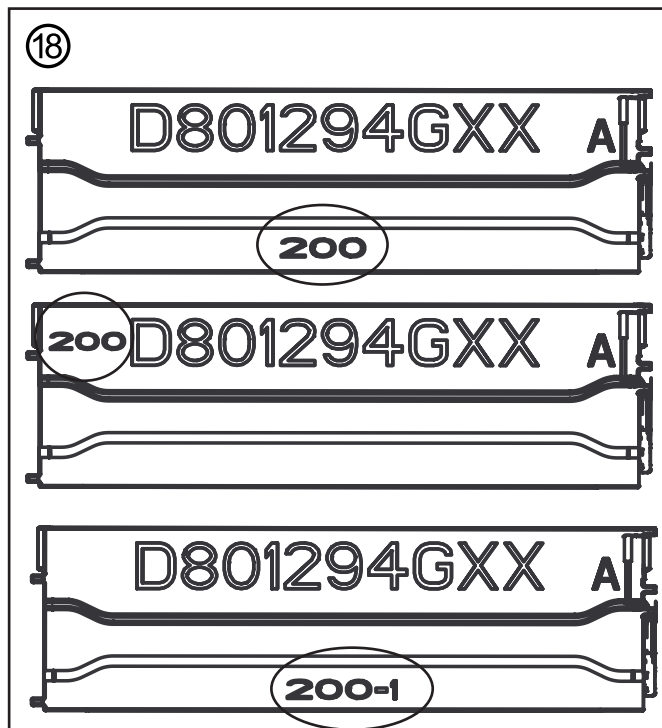

Carefully review **BOTH** of the COLLECTION CELLS for the "200/200-1" mark. If the "200/200-1" mark is visible on **BOTH** COLLECTION CELLS, they may be washed. If the "200/200-1" mark is **NOT** visible, the COLLECTION CELLS **cannot** be washed.

NOTE: The PRE-FILTER may also be washed **ONLY** if the COLLECTION CELLS show a "200/200-1". Follow the same instructions to wash the PRE-FILTER - being sure to tap gently and wipe off any visible water droplets.

CAUTION

Washing COLLECTION CELLS that do **NOT** have the "200/200-1" mark on them can result in degradation of the Air Cleaner system. Failure to follow this instruction could result in property damages.

1. If the COLLECTION CELLS do have the "200/200-1" mark on them, they may be washed using a low pressure water spray, such as a sink sprayer or garden hose. Residue like tobacco smoke may require warm water to be removed.
 - Do **NOT** use soap or detergent in cleaning the COLLECTION CELLS.
 - Do **NOT** immerse the COLLECTION CELLS completely in water.
 - Do **NOT** place the COLLECTION CELLS into a dishwasher to clean.
 - **ALLOW THE COLLECTION CELLS TO DRY THOROUGHLY BEFORE INSTALLING.**
2. After washing, drain as much water as possible from the COLLECTION CELLS.
3. Holding the sides of the COLLECTION CELLS, gently tap the cells on a flat surface to dislodge any water droplets inside the COLLECTION CELLS. After tapping, wipe down the surfaces of the COLLECTION CELLS to remove any visible droplets of water.

Service Facts

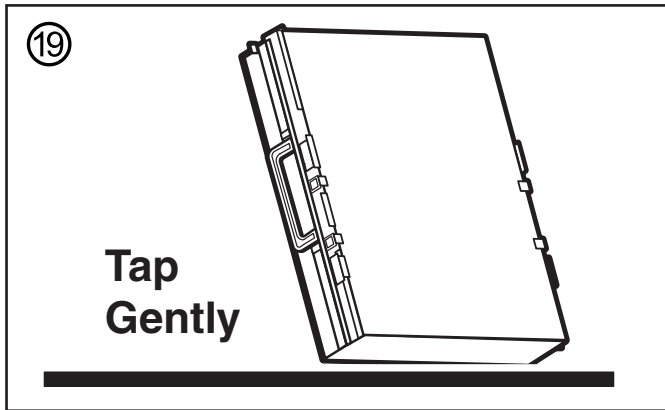

4. When there are no visible water droplets left in the COLLECTION CELLS, reinstall them into the Air Cleaner cabinet. Be sure to fold the COLLECTION CELLS handles flat. Refer to Figure 20.

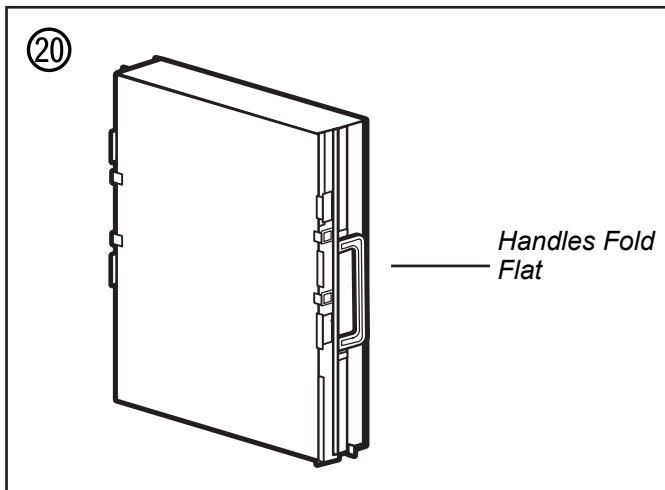

5. Replace the door onto the Air Cleaner cabinet.
6. Ensure that the power cord is connected to the Air Cleaner and press the POWER button.

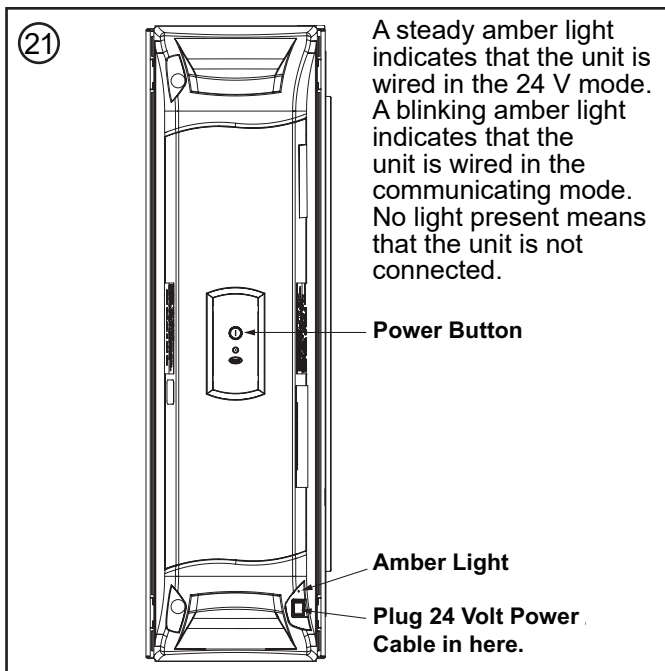

NOTE: Once you press the POWER button, the first LED will be on and it will start flashing after the first 10 [12] minutes of indoor fan operation. This is normal operation.

7. On the thermostat, reset the indoor fan operation to the desired mode. Turn the air system back on at the Comfort Control (thermostat).

NOTE: The field charger should never be subjected to water. The field charger should only be cleaned by a trained service professional.

NOTE: The pre-filter may also be washed ONLY if the COLLECTION CELLS show a "200/200-1". Follow the same instructions to wash the PRE-FILTER - being sure to tap gently and wipe off any visible water droplets.

RESET TIMERS

To reset the PRE-FILTER timer, press and hold the RESET button until the PRE-FILTER LED turns off. (1 to 2 seconds). To reset the Collection Cell timer, press and hold the RESET button until the COLLECTION CELL LED's turn off. (4 to 5 seconds).

In a communicating system, the filter reset timers can also be reset at the communicating comfort control. If two air cleaners are connected on the same system, reset all timers on both air cleaners at the same time to the same settings. The comfort control will only report one air cleaner timer and this methodology will allow the air cleaners to remain on the same cleaning schedule.

CLEANING THE FIELD CHARGER

1. Turn off the Air Cleaner and remove the Power Door.
2. Bend the FIELD CHARGER metal locking tabs down against the case.
3. Remove the FIELD CHARGER from the case. Lay the FIELD CHARGER on a secured flat surface.

⚠ CAUTION

FIELD CHARGER PINS ARE SHARP.

DO NOT BEND FIELD CHARGER PINS. WEAR APPROPRIATE GLOVES WHEN HANDLING THE FIELD CHARGER. FAILURE TO HANDLE FIELD CHARGER PINS PROPERLY MAY RESULT IN MINOR TO MODERATE INJURY.

4. Wipe down the faceplate of the FIELD CHARGER with a dry shop towel or use a vacuum cleaner. Do not disassemble the FIELD CHARGER.
5. Push a block of styrofoam down over the FIELD CHARGER Pin.

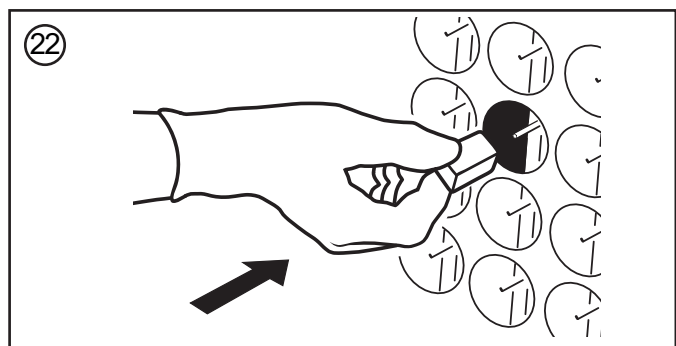

6. Rotate the styrofoam block on the FIELD CHARGER Pin.

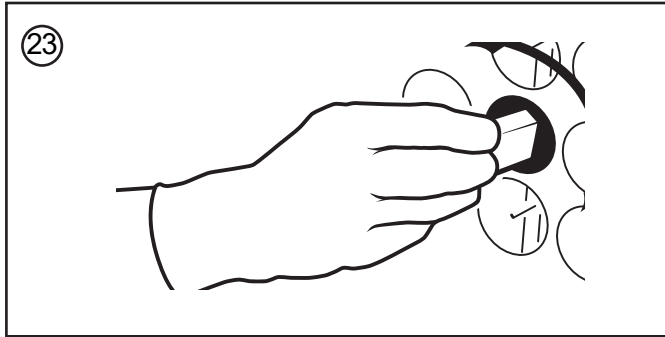

7. Use the styrofoam block to clean the faceplate opening edges.
8. Repeat steps 5, 6 and 7 for each FIELD CHARGER Pin.
9. Put FIELD CHARGER back into the Air Cleaner frame and bend the locking tabs back up against the FIELD CHARGER.

TESTING THE POWER DOOR HIGH VOLTAGE POWER SUPPLY

Tools Required:

A High voltage Probe and a compatible Volt Meter or a Screwdriver, Jumper Wire with Alligator Clips on each end, tape and dry paper.

TESTING WITH A HIGH VOLTAGE PROBE

1. Turn off the Air Cleaner and remove the Power Door.
2. Form a piece of wire that will go through the interlock switch opening and depress the interlock switch blade. Tape it in place.

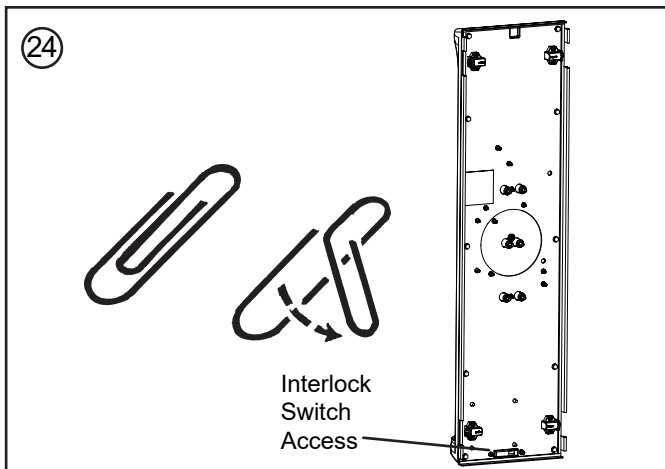

⚠ WARNING

High Voltage is present for this test.

3. Turn on the Air Cleaner, and then enter the SET-UP mode by pushing and holding both the POWER button and the RESET button for 5 [6] seconds. The bar graph display will show the Air Cleaners current settings (see SET-UP MODE instructions). The top three Red LEDs should be on for this test. The three Red LEDs being on indicates that the Air Cleaner Power level setting is set at the 9.6 KV position. If all three are NOT on, press the POWER button

three times and then press the RESET button until you get all three Red LEDs on. Now press and hold both the POWER button and the RESET button for five seconds then release these buttons to leave the SET-UP mode. The first Green LED should be on and then start flashing after the time delay to 'on' has expired. The Air Cleaner has to have a call for operation for the first Green LED to flash on and off. (A call for indoor blower or heat is a call for operation.)

4. When the first Green LED is flashing on and off connect the High Voltage Probe and compatible volt/ohm meter per their manufacturers' instructions.
5. Touch the tip of the High Voltage Probe to the Power Door High Voltage terminal and read the volt meter.
6. If the voltage read during this test is 9.6 KV + or – 600 volts the Power Door is working correctly. Replace Power Door with a new Power Door if the high voltage is not correct.
7. Turn off the Air Cleaner by pushing the POWER button.
8. Remove the wire and tape used to defeat the interlock switch.
9. Replace Power Door.

TESTING WITH A SCREWDRIVER, A JUMPER WIRE AND A DRY PIECE OF PAPER

1. Turn off the Air Cleaner and remove the Power Door.
2. Form a piece of wire that will go through the interlock switch opening and depress the interlock switch. Tape it in place. See Figure 24.
3. Tape a piece of paper to a screwdriver blade with ½ inch of the paper sticking out in front of the blade. Do not put the tape over the end of the screwdriver blade.

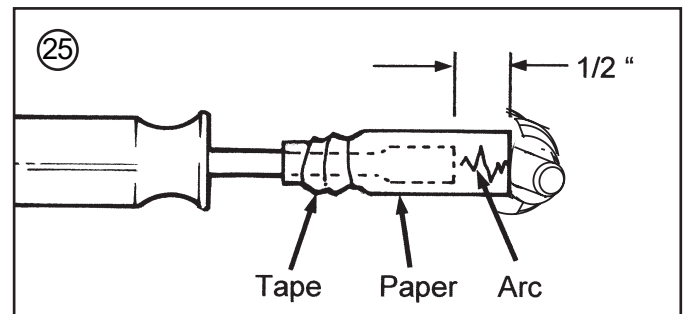

⚠ CAUTION

Do not expose the filter to UV light. UV light can cause the plastic materials to deteriorate which may lead to filter damage.

4. Connect the jumper wire using the alligator clips to the screwdriver and the Power Door metal frame as illustrated in Figure 26.

⚠ WARNING

High Voltage is present for this test.

5. Turn on the Air Cleaner, and then enter the SET-UP mode by pushing and holding both the POWER button and the RESET button for 5 [6] seconds. The bar graph display will show the Air Cleaners current settings (see SET-UP MODE instructions). The top three Red LEDs should be on

Service Facts

for this test. The three Red LEDs being on indicates that the Air Cleaner Power level setting is set at the Maximum / 9.6 KV position. If all three are NOT on, press the POWER button three times and then press the RESET button until you get all three Red LEDs on. Now press and hold both the POWER button and the RESET button for 5 [6] seconds then release these buttons to exit the SET-UP mode. The first Green LED will be on and it will start flashing after the first 10 [12] minutes of indoor fan operation. The Air Cleaner has to have a call for operation for the first Green LED to flash on and off. (A call for indoor blower or heat is a call for operation.)

6. When the first Green LED is flashing on and off, take the screwdriver by the plastic handle and move the blade end of the screwdriver near the Power Door High Voltage terminal. When the end of the paper touches the High Voltage terminal the High Voltage should arc across the paper. When the arc occurs, the High Voltage Supply will shut down and stay off for one minute.
7. Turn off the Air Cleaner by pushing the POWER button.
8. Remove the wire and tape used to defeat the interlock switch.
9. If the arc occurred when the end of the paper was near or touching the Power Door High Voltage terminal during this test, the Power Door assembly is OK. If no arc occurred replace Power Door with a new Power Door.

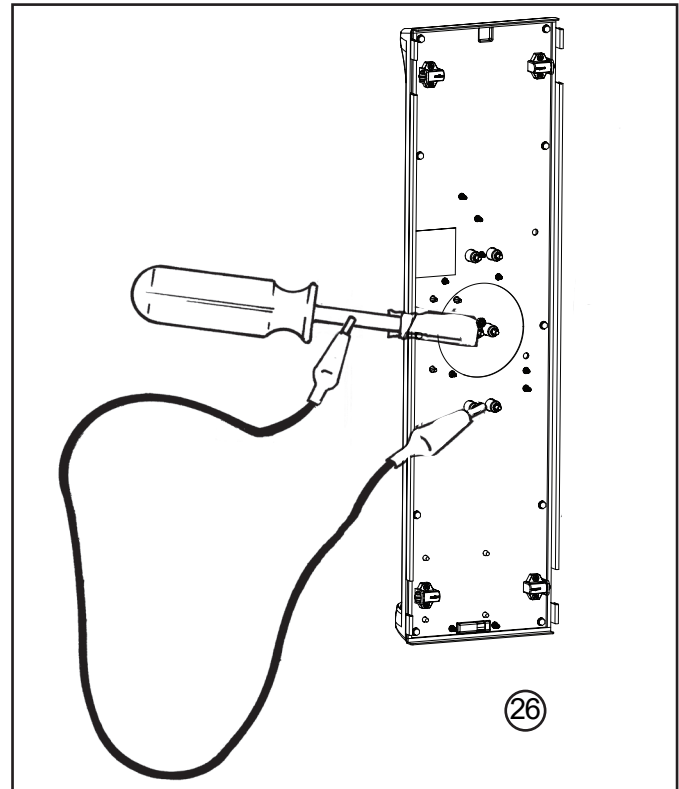

PRESSURE DROP

PRESSURE DROP AT SPECIFIC AIRFLOW PER MODEL									
	400 CFM	600 CFM	800 CFM	1000 CFM	1200 CFM	1400 CFM	1600 CFM	1800 CFM	2000 CFM
EFD145DLFR000**	0.06	0.10	0.16	0.23	0.30				
EFD175DLFR000**	0.05	0.08	0.12	0.17	0.22	0.28	0.34		
EFD210DLFR000**	0.04	0.06	0.09	0.12	0.15	0.20	0.24	0.29	0.34
EFD245DLFR000**	0.03	0.04	0.06	0.09	0.12	0.15	0.19	0.22	0.26
EFD17DDLFR000**	0.07	0.11	0.18	0.25	0.33	0.42			
EFD21DDLFR000**	0.05	0.09	0.13	0.18	0.23	0.29	0.37		
EFD175DLAH000**	0.07	0.11	0.18	0.25	0.33				
EFD215DLAH000** TFD215CLAH005E	0.04	0.08	0.12	0.17	0.24				
EFD235DLAH000** TFD235CLAH005E	0.06	0.09	0.13	0.18	0.23	0.29	0.35		
EFD260DLAH000** TFD260CLAH005E	0.04	0.07	0.10	0.14	0.18	0.23	0.28	0.34	0.39

TROUBLESHOOTING

Service Indications	Service Checks
Indoor Blower ON/ Air Cleaner First Green LED OFF	<ol style="list-style-type: none"> 1. Check that the Power Door is installed correctly and the latches closed. The actuator tab must engage the door safety switch. 2. Check the air cleaner power/control cable. 3. Push the power button once. 4. Check for 24 Volts AC at the Air Cleaner power plug.
Indoor Blower ON/ Air Cleaner First Green LED ON, Not Flashing	<ol style="list-style-type: none"> 1. Air Cleaner is in the 10 [12] minute dry cycle. 2. No call for Air Cleaner Operation due to no 24 Volts AC call going to G / W or request through the data line from the (Communicating System) Furnace or Air Handler. 3. There is no High Voltage being provided to the Field Charger or the Collection Cells. Inspect the Field Charger assembly and Collection Cells for any foreign material that may be lodged in them. Clean as needed, reassemble and test. 4. If the Air Cleaner still does not work, remove Power Door from the Air Cleaner housing.
<p>⚠ WARNING</p> <p>HIGH VOLTAGE WILL BE PRESENT FOR THE REMAINDER OF THIS TEST.</p>	
	<ol style="list-style-type: none"> 5. With the indoor blower running and the power cord plugged into the Air Cleaner, use a tool to activate the Power Door interlock switch. Push the power button once. The first Green LED should come on and after the time delay it should start to flash. If the first Green LED does not start to flash the fault is with the Power Door.
Indoor Blower ON/ Three Yellow LEDs Flashing	<ol style="list-style-type: none"> 1. Remove the Power Door, Field Charger & Collection Cells. Inspect for foreign material, clean if needed.
Indoor Blower ON/ Three Red LEDs Flashing	<ol style="list-style-type: none"> 1. This indicates service is needed. See Service Facts page 11 for fault code information.

Service Facts

COMPONENT FAILURE EVALUATION

Component Failure Evaluation

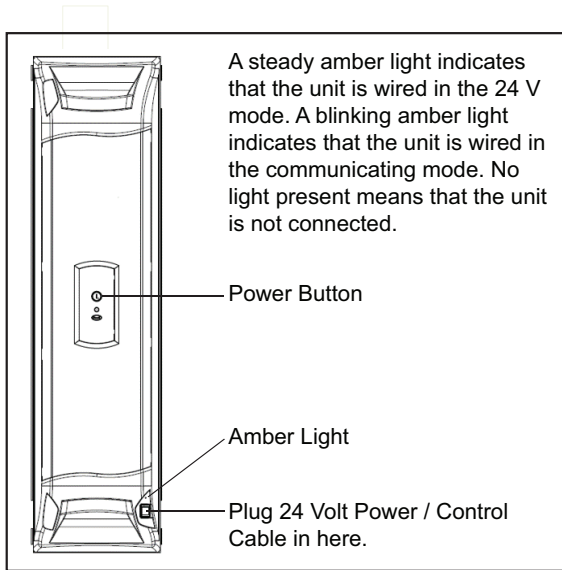

This whole house air cleaner can be installed either as part of a communicating system or as part of a traditional 24 volt system

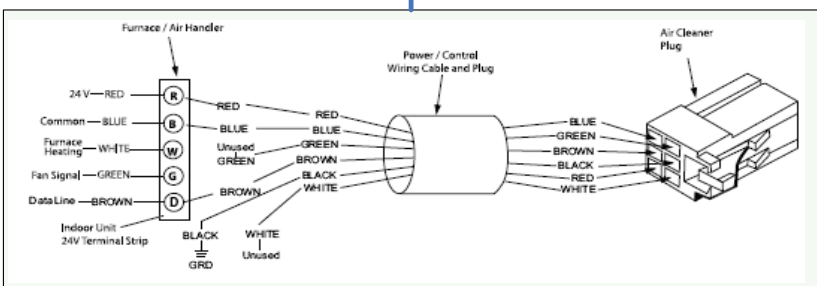
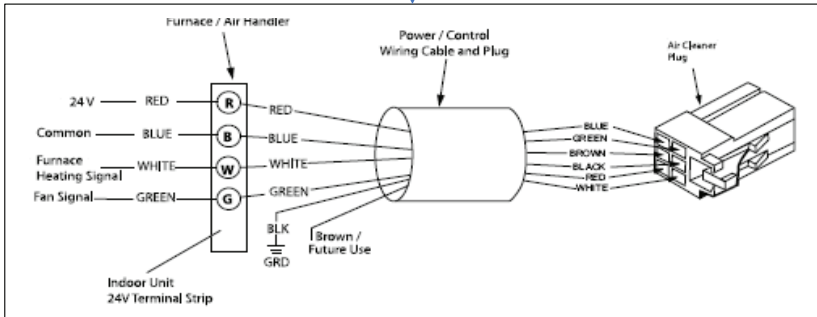
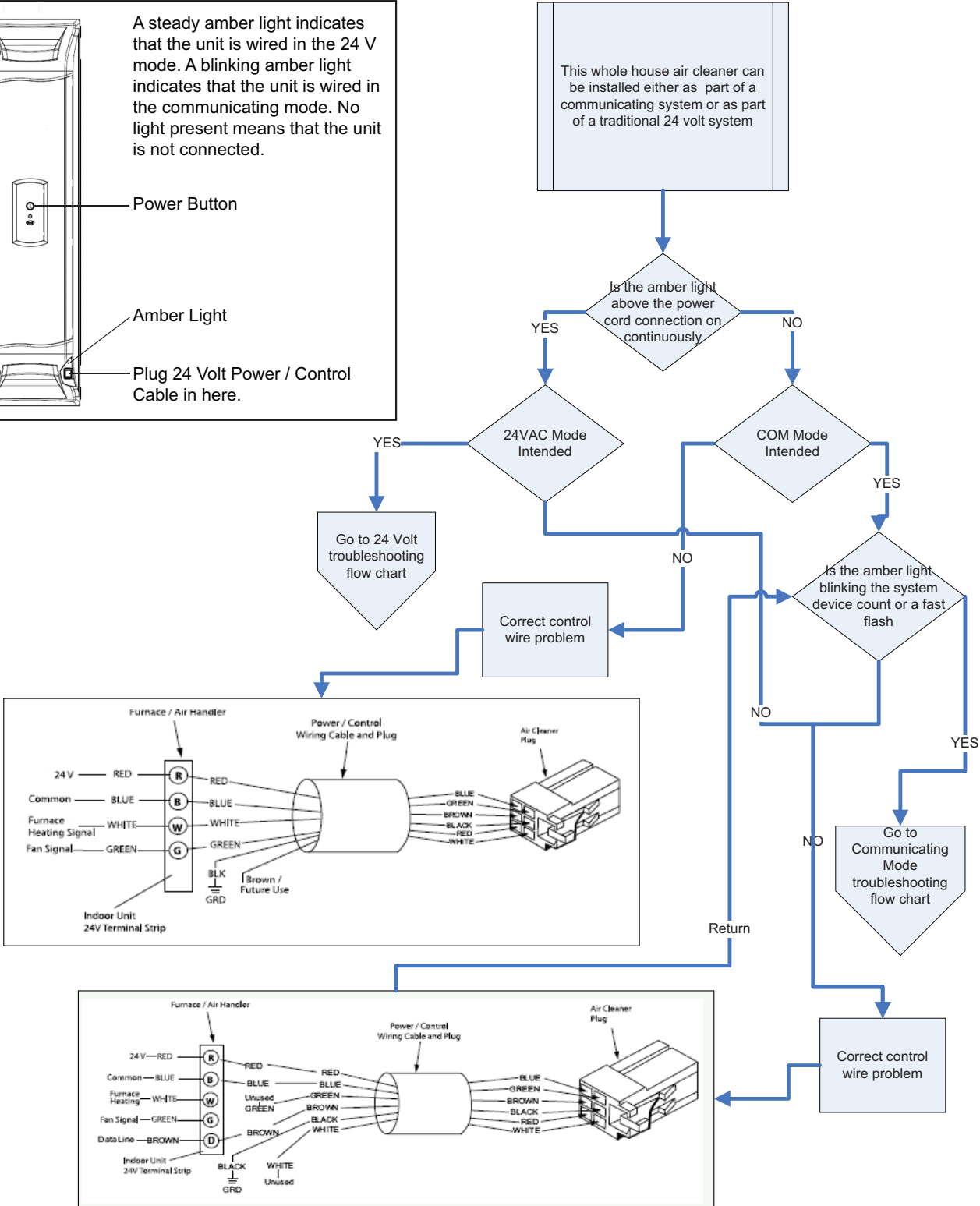

Component Failure Evaluation in 24 Volt Mode

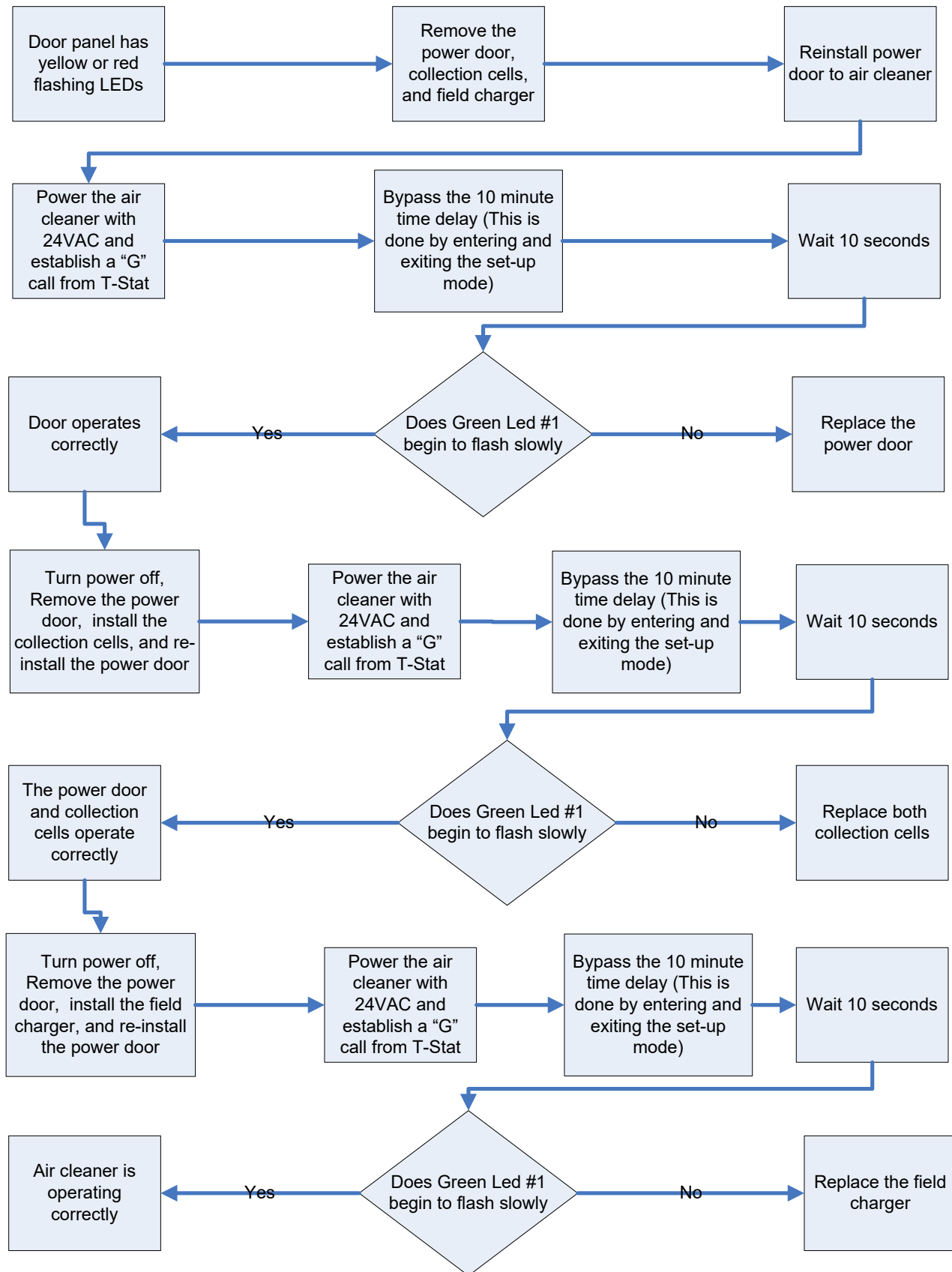

Component Failure Evaluation in Communicating Mode

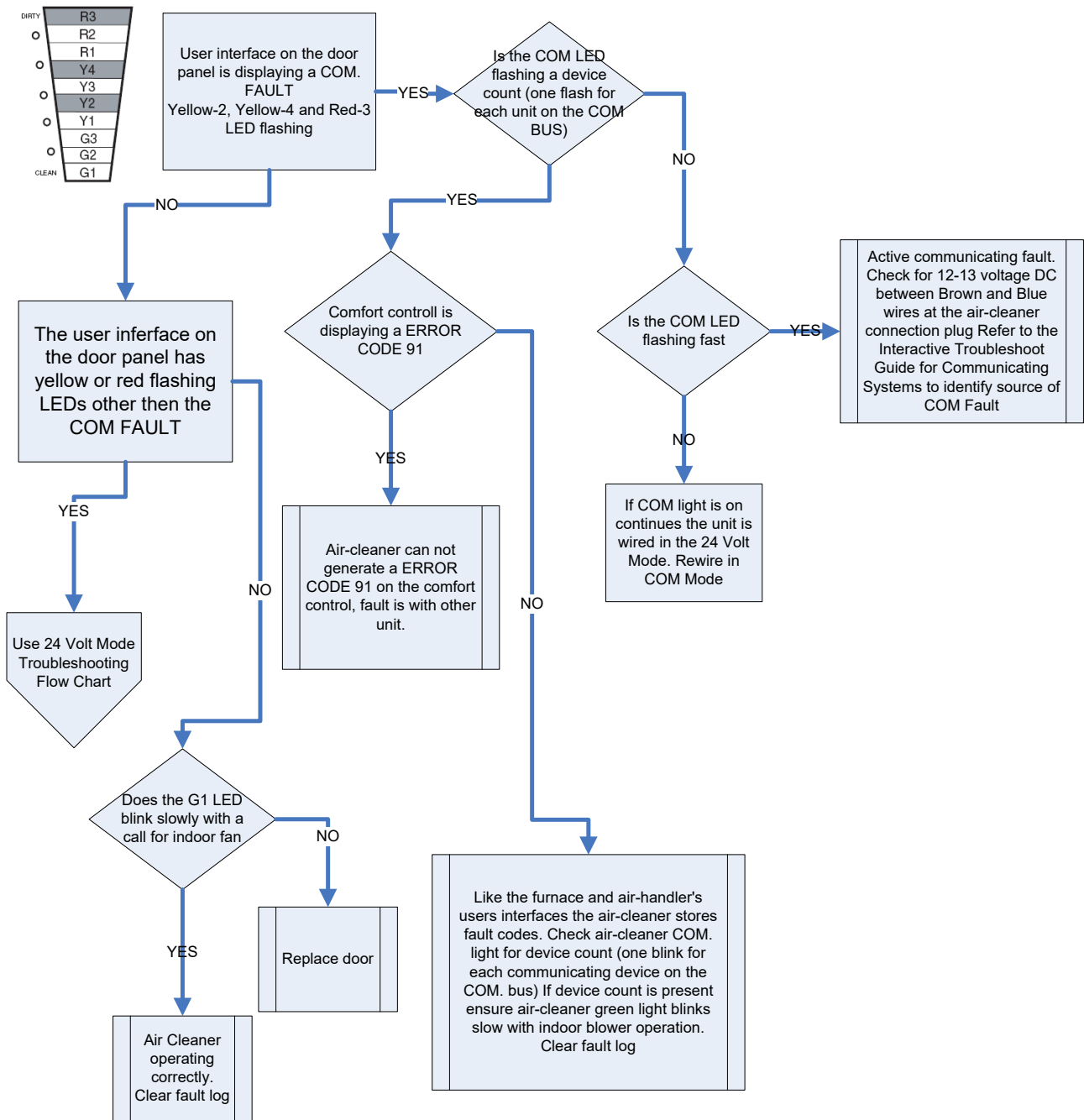

About Trane and American Standard Heating and Air Conditioning
 Trane and American Standard create comfortable, energy efficient indoor environments for residential applications. For more information, please visit www.trane.com or www.americanstandardair.com

The manufacturer has a policy of continuous data improvement and it reserves the right to change design and specifications without notice. We are committed to using environmentally conscious print practices.