

Envirowise[™]

INDOOR AIR SYSTEMS



Installation Instructions

INSTALLATION BY A HVAC PROFESSIONAL IS RECOMMENDED

The Envirowise 98H is a whole house ventilating dehumidifier that is integrated into the heating and cooling system to provide the ultimate in comfort, health and property protection through:

- Dehumidification
- Fresh Air Ventilation (Optional)
- Air Filtration

HVAC Installer: Please Leave Manual for Homeowner

P/N: EDHUM098 Serial No.: _____ Install Date: _____

Installing Dealer: _____



TABLE OF CONTENTS

Safety Instructions	3
Specifications	4
General Set Up	5
Attaching Duct Collars	5
Electrical Requirements	7
Drain Installation	8
Ducting to HVAC Systems	9
Recommended HVAC System Installations	11
No Existing Ductwork Installation	12
Recommended Closet Installation	13
Fresh Air Ventilation	14
Determine Ventilation Requirements	15
Controls	16
Filter Instructions	18
Optional Accessories	19
Service	20
Troubleshooting.....	20

Ingersoll Rand is committed to manufacturing quality products. To maintain our standards, product specifications may change without notice.



Ingersoll Rand, 6200 Troup Hwy. Tyler, TX 75707

Items Included in Box:

- Envirowise 98H Dehumidifier
- Envirowise 98H Installation Instructions
- Envirowise 98H Leveling Feet

SAFETY INSTRUCTIONS

READ THE INSTALLATION, OPERATION AND MAINTENANCE INSTRUCTIONS CAREFULLY BEFORE INSTALLING AND OPERATING THIS DEVICE. PROPER ADHERENCE TO THESE INSTRUCTIONS IS ESSENTIAL TO OBTAIN MAXIMUM BENEFIT FROM YOUR ENVIROWISE WHOLE HOUSE VENTILATING DEHUMIDIFIER.

⚠ WARNING!

THIS SYMBOL MEANS IMPORTANT INSTRUCTIONS. FAILURE TO HEED THEM CAN RESULT IN SERIOUS INJURY OR DEATH.

⚠ CAUTION!

THIS SYMBOL MEANS IMPORTANT INSTRUCTIONS. FAILURE TO HEED THEM CAN RESULT IN INJURY OR MATERIAL PROPERTY DAMAGE.

Registrations



The Envirowise 98H conforms to unified standard UL 60335-2-40 and CSA standard C22.2.60335-2-40.

⚠ WARNING!

120 VOLTS MAY CAUSE SERIOUS INJURY FROM ELECTRIC SHOCK. DISCONNECT ELECTRICAL POWER BEFORE STARTING INSTALLATION OR SERVICING, AND LEAVE POWER DISCONNECTED UNTIL INSTALLATION OR SERVICE IS COMPLETED.

⚠ CAUTION!

READ ALL INSTRUCTIONS BEFORE BEGINNING INSTALLATION.

ALWAYS USE CAUTION AND WEAR CUT RESISTANT GLOVES WHEN HANDLING SHEET METAL.

IMPROPER INSTALLATION MAY CAUSE PROPERTY DAMAGE OR INJURY. INSTALLATION, SERVICE, AND MAINTENANCE MUST BE PERFORMED BY A QUALIFIED SERVICE TECHNICIAN.

DEHUMIDIFIER IS HEAVY. HANDLE WITH CARE AND FOLLOW INSTALLATION INSTRUCTIONS. DO NOT USE IN POOL APPLICATIONS, OR WARRANTY WILL BE VOID.

NEVER OPERATE A UNIT WITH A DAMAGED POWER CORD. IF THE POWER CORD IS DAMAGED, IT MUST BE REPLACED BY THE MANUFACTURER, ITS SERVICE AGENT, OR A SIMILARLY QUALIFIED PERSON IN ORDER TO AVOID A HAZARD.

THIS APPLIANCE IS NOT INTENDED FOR USE BY PERSONS (INCLUDING CHILDREN) WITH REDUCED PHYSICAL, SENSORY OR MENTAL CAPABILITIES, OR LACK OF EXPERIENCE OR KNOWLEDGE, UNLESS THEY HAVE BEEN GIVEN SUPERVISION OR INSTRUCTION CONCERNING THE USE OF THE APPLIANCE BY A PERSON RESPONSIBLE FOR THEIR SAFETY. CHILDREN SHOULD BE SUPERVISED TO ENSURE THAT THEY DO NOT PLAY WITH THE APPLIANCE.

SPECIFICATIONS

Part Number:	EDHUM0981H1MDA		
Blower:	320 CFM @ 0.0" WG 297 CFM @ 0.2" WG 215 CFM @ 0.4" WG		
Power:	670 Watts @ 80°F and 60% RH		
Supply Voltage:	115 VAC – 1phase – 60 Hz		
Current Draw:	5.9 Amps		
Transformer Protection:	Push Button Reset (located near power cord)		
Circuit Requirement:	15 Amps		
Energy Factor:	2.95 L/kWh		
Operating Range:	49°F Min, 95°F Max (Inlet Air Temperature) 34°F Min, 135°F Max (Outside Cabinet)		
Sized For:	Up to 2,300 Square Feet		
Water Removal at:	80°F and 60% RH	70°F and 60% RH	
Capacity:	98 Pints/Day	75 Pints/Day	
Efficiency:	6.1 Pints/kWh	5.4 Pints/kWh	
Duct Connections:	6" Round Inlet; 10" Round Inlet; 10" Round Outlet		
Air Filter:	MERV-11, Mini Pleat		
Efficiency:	65% ASHRAE Dust Spot		
Size:	14" x 17.5" x 1.75"		
Optional Air Filter:	MERV-14, Embossed Pleat (will need filter housing)		
Optional Air Filter:	MERV-14, Embossed Pleat (will need filter housing)		
Efficiency:	95% ASHRAE Dust Spot		
Size:	20" x 24" x 4"		
Power Cord:	9', 115VAC, Ground		
Internal Insulated Cabinet:	Yes		
Drain Connection:	3/4" Threaded Female NPT		
Refrigerant Type:	R410A (Refer to manufacturers label for more information.)		
Refrigerant Amount:	1 lb. 9 oz.		
Dimensions:	Unit With Collars	Unit Without Collars	Shipping
Width:	14 1/2"	14 1/2"	23"
Height:	19 1/2"	19 1/2"	30"
Length:	32 3/8"	26"	40"
Weight:	81 lbs.	80 lbs.	95 lbs.

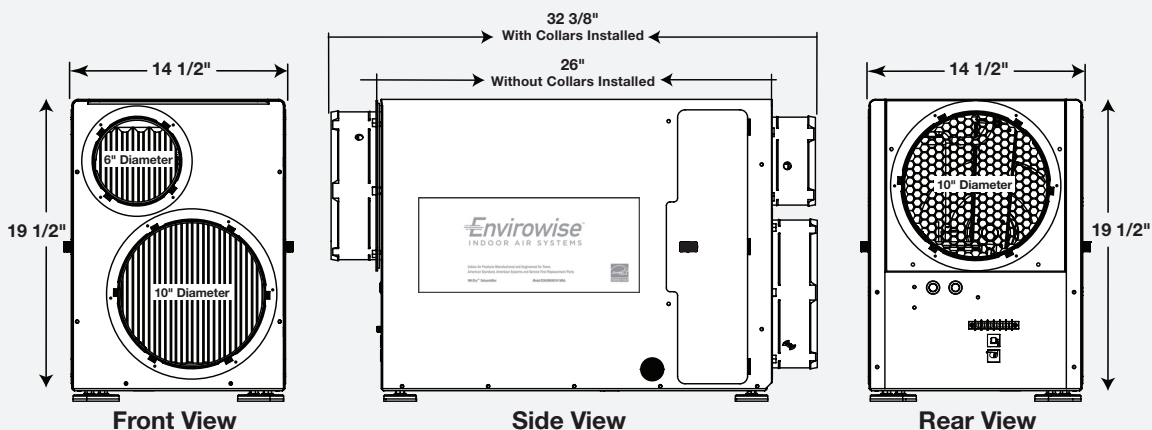

⚠ CAUTION!

REMOVE COMPRESSOR SHIPPING TIE FROM THE UNIT. FAILURE TO REMOVE SHIPPING TIE WILL CAUSE EXCESS VIBRATION TO BE TRANSMITTED TO THE FRAME.

Removal of Compressor Shipping Support

The Envirowise 98H uses a compressor to power the refrigeration system. To protect the compressor and refrigeration system during shipping, a plastic tie wrap secures it to the unit's frame. Remove the tie wrap by cutting the tie wrap and pulling from the unit as shown. After removing tie wrap, insert plastic plugs provided into the holes.



Important Precautions

- The device is designed to be installed indoors in a space that is protected from rain and flooding.
- Install the unit with enough space to access one of the side panels for maintenance and service.
- Avoid directing the discharge air at people. The dehumidifier should be used in the upright position.
- If used near a water source, be certain there is no chance the unit could fall into the water or get splashed and that it is plugged into a dedicated circuit and Ground Fault Circuit Interrupter (GFCI) protected outlet.
- DO NOT use the dehumidifier as a bench or table.
- DO NOT place the dehumidifier directly on structural building members without vibration absorbers or unwanted noise may result. Place the Envirowise 98H on supports to raise the base of the unit.
- A drain pan with a float switch MUST be placed under the dehumidifier if installed above a living area or above an area where water leakage could cause damage.

Location Considerations

- Allow sufficient clearance to handle the unit's overall dimensions as well as the necessary return and supply ductwork to the unit.
- Allow sufficient clearance for filter removal and to prevent airflow obstruction.
- Electrical service access will require the removal of a side panel. Allow sufficient clearance on a side of the unit.
- Locate the dehumidifier in an area where the cord's length (9') easily reaches a 115 VAC electrical outlet with a minimum of a 15 Amp circuit capacity.
- Locate the dehumidifier in an area where field wiring the control (low voltage) to the unit will be possible.
- It is recommended that a backdraft damper be used in the discharge duct of the Envirowise 98H, especially when connecting to the supply ducting system. The backdraft damper prevents supply air from counter flowing through the Envirowise 98H when it is not operating. The dehumidifier's location should be chosen to allow installation of this accessory if necessary.
- The Envirowise 98H may be suspended from structural members with steel hanger straps or a suitable alternative, ensuring the assembly supports the dehumidifier's base in its entirety. DO NOT hang the Envirowise 98H from its cabinet.
- Allow for proper routing and drainage of needed drain pipes.

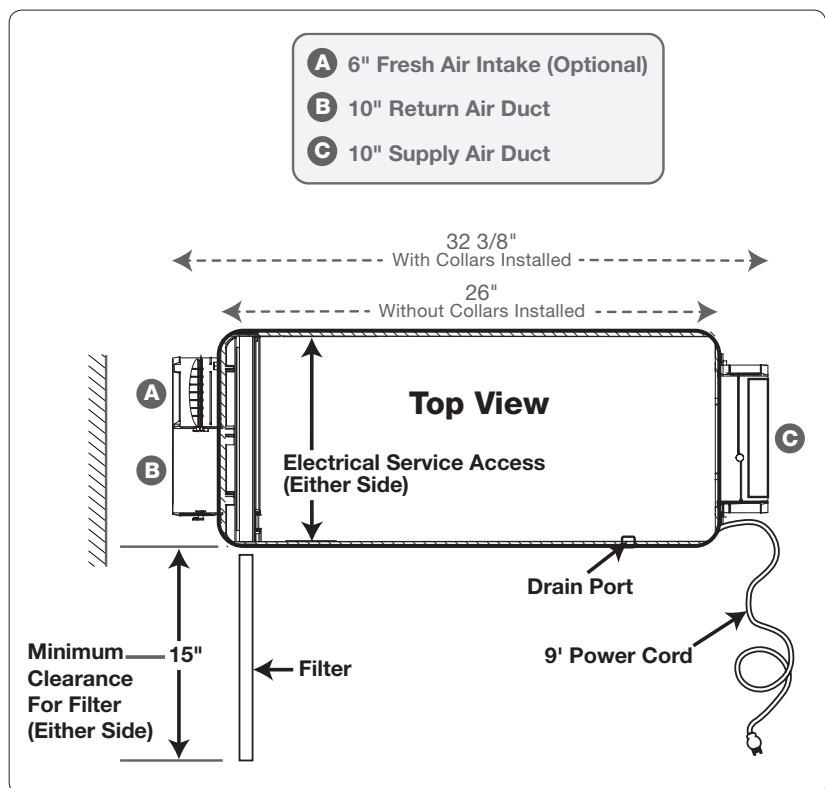

ATTACHING DUCT COLLARS

Fresh Air Ventilation Duct

Fresh air ventilation is optional. A 6" diameter duct is attached to the unit. The 6" duct should be capped if fresh air is not desired. If setting up the unit to provide fresh air ventilation, see page 15.

Return Air Inlet

A 10" diameter duct collar is attached to the unit.

Supply Air Outlet

The back panel of the dehumidifier can be rotated to allow for horizontal flow through or vertical flow through of the supply air.

- **Horizontal Flow Through**

The unit ships configured for a horizontal flow through. A 10" diameter duct collar is attached to the unit.

- **Vertical Flow Through**

Remove the exhaust panel using a T25 torx bit. Rotate the panel so the exhaust collar is located on the top of the unit. Align screw holes and snap the panel onto the base. Secure the exhaust panel to the base by replacing the six screws.

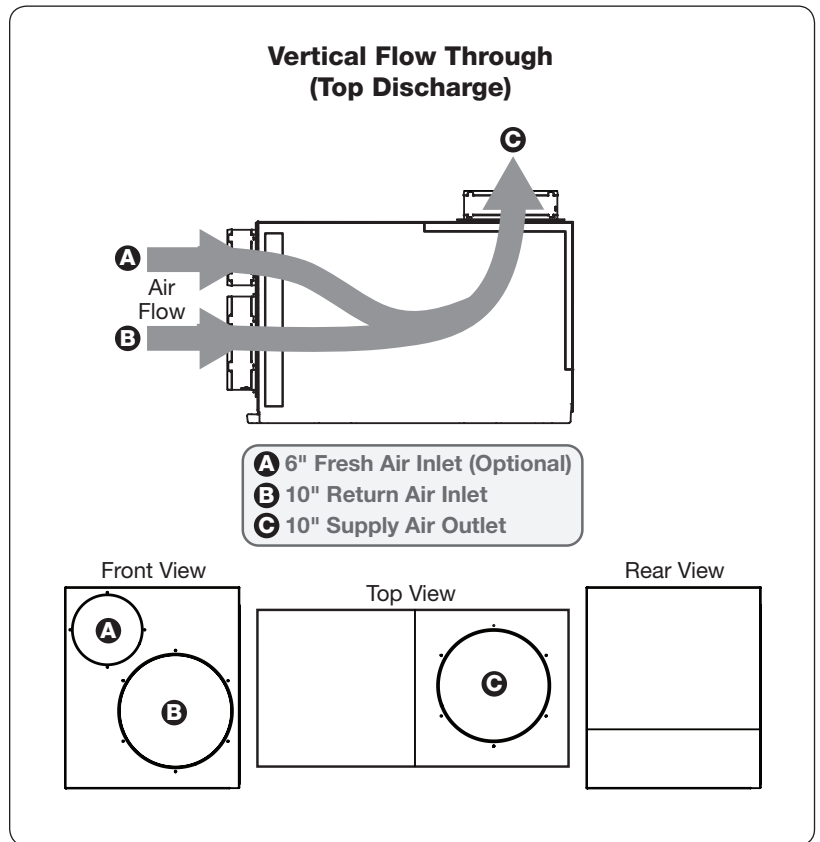
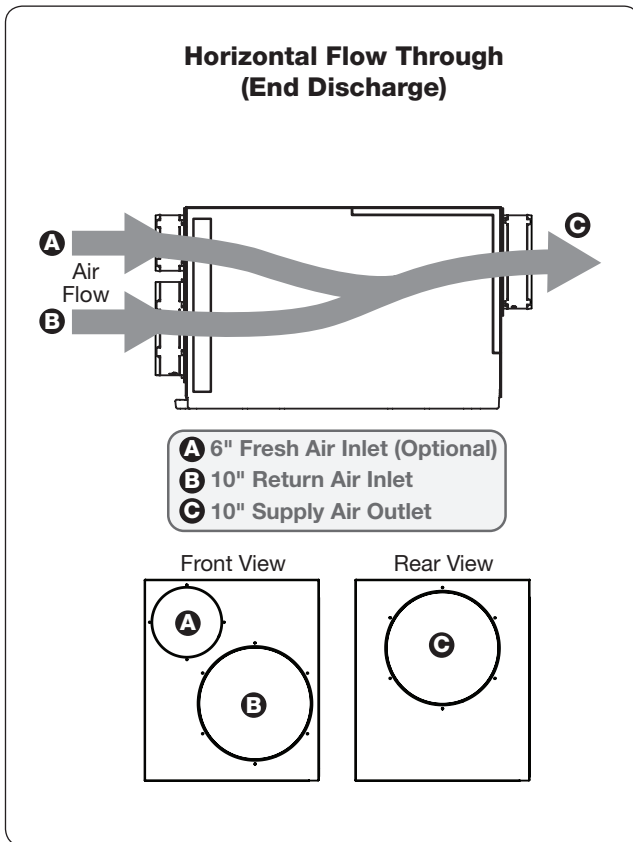

GENERAL SET UP

Drain Installation

The Envirowise 98H generates condensate.

Place a secondary drain pan with a float switch under the dehumidifier if it is suspended above a finished area or above an area where water leakage could cause damage.

A drain trap is required for the dehumidifier to drain properly. Install a 3/4" threaded male NPT adapter to the drain pan. Install a drain pipe assembly utilizing 3/4" PVC pipe to transport the condensate to a drain. Pitch of drain should be 1" per 10'.

An optional condensate pump kit is available for use with the Envirowise 98H and may be installed if lift is required to dispose of condensate. Condensate is automatically pumped to a remote location when the water level in the pump's reservoir rises to close the float switch.

The pump also contains a safety float switch. The white leads from this switch extend from beneath the pump cover. This switch should be installed in series with the field wire that connects to the common lead from the Envirowise 98H to the control panel. If the pump fails, this switch opens the common control circuit and stops water production before the reservoir overflows. Contact a qualified electrician to install the safety float switch to the Envirowise 98H dehumidifier.

Note: An optional condensate pump kit can be purchased through your dealer.

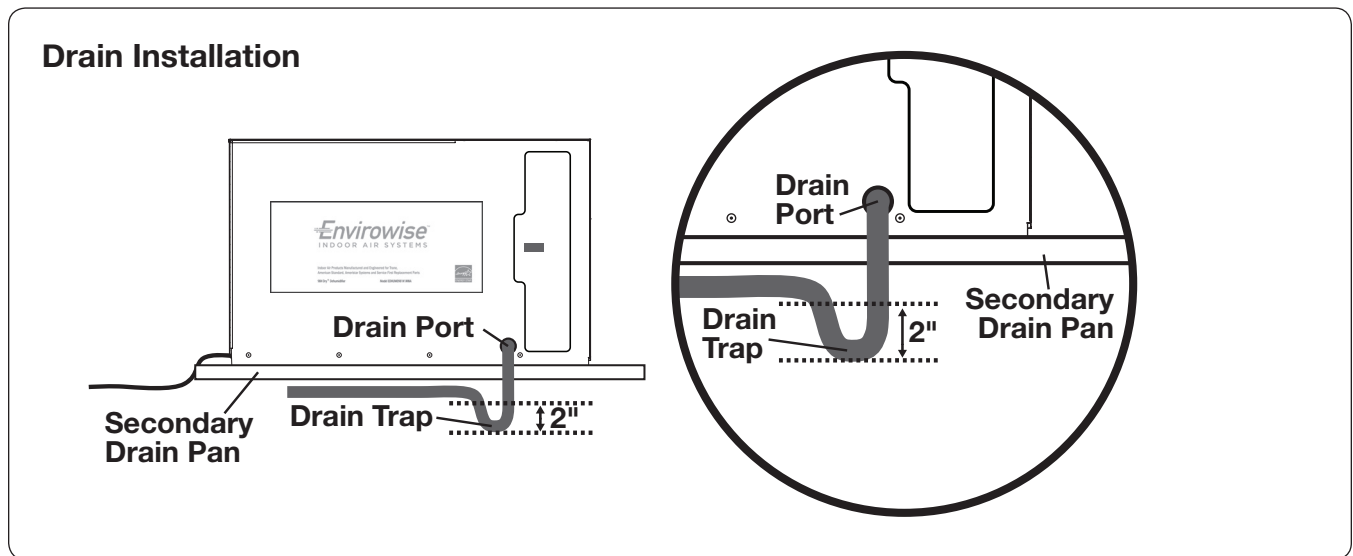

Ducting to HVAC Systems

The recommended installation creates a separate return for the Envirowise 98H in a central area of the structure. Duct the supply of the unit to the air return of the existing HVAC system. Connect an insulated duct from outside to the 6" collar of the Envirowise 98H to provide fresh make-up air (optional).

CAUTION!

DO NOT CONNECT WITH A STATIC PRESSURE GREATER THAN OR EQUAL TO +0.5 WG. CONTACT TECHNICAL SUPPORT AT (800) 533-7533 FOR ADDITIONAL DETAILS.

Ducting Considerations:

- All flexible ducting connected to the Envirowise 98H should be UL listed.
- A short piece of flexible ducting on all Envirowise 98H duct connections is recommended to reduce noise and vibration transmitted to rigid ductwork in the structure.
- Use a minimum 10" diameter round or equivalent rectangular duct for total duct lengths of up to 25'. Use a minimum 12" diameter round or equivalent rectangular duct for longer lengths.
- Grills or diffusers on the duct ends must not excessively restrict airflow.
- A length of 10" or more of insulated flex duct or any other vibration isolating material on the outlet of the Envirowise 98H will reduce air noise from the blower.
- Effective dehumidification may require that ducting be branched to isolated, stagnant air flow areas. When ducting to two or three areas, use 8" or larger diameter branch ducting. When ducting to four or more areas, use 6" or larger diameter branch ducting. Provisions must be made to provide airflow from supply locations to the central return location. Proper air distribution is important to ensure even humidity control and heat distribution throughout the structure.
- DO NOT locate the return in a bathroom or a kitchen.

GENERAL SET UP

Recommended HVAC Ducting Installations

The recommended installation draws air from a dedicated indoor air return and ducts the supply of the dehumidifier to the air return of the existing HVAC system. Utilize the optional fresh air ventilation duct to provide outside air.

- Install a dedicated 10" air return for the Envirowise 98H from a central area of the structure.
- Install an insulated duct from outside to the 6" collar of the Envirowise 98H to provide fresh air ventilation (optional).
- Duct the supply of the Envirowise 98H to the return side of the existing HVAC system with a backdraft damper. HVAC system interlock is recommended.
- DO NOT locate return in a bathroom or kitchen.
- The optional D30 or a system thermostat control with integrated Dehumidification software should be located remotely from the dehumidifier and placed in a central location.

Attic Installation - Dedicated Return to HVAC Return

Create a separate return for the Envirowise 98H in a central area of the building.

Installing the supply air from the Envirowise 98H to the return of the HVAC system requires the HVAC fan to run when the Envirowise 98H is operating.

HVAC system fan interlock is recommended to reduce potential comfort issues with this application.

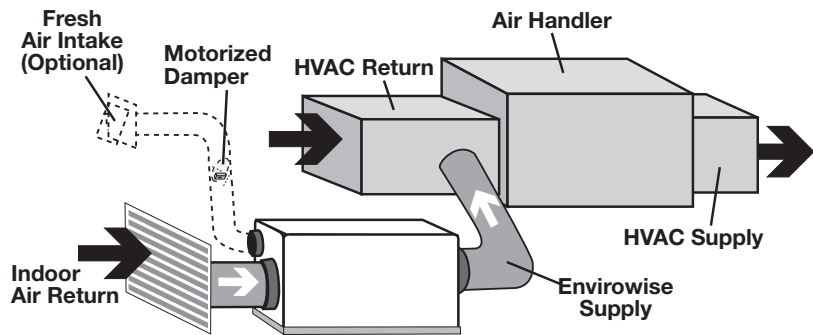

Basement/Crawl Space Installation - Dedicated Return to HVAC Return

Duct the supply of the Envirowise 98H to a 10" x 10" x 10" tee damper that is 20 percent open to the basement/crawl space.

Positive Pressurization of crawl spaces with dehumidification added could potentially bring unwanted, unhealthy air into living spaces. The recommended application with dehumidification added is to achieve neutral pressure in crawl spaces.

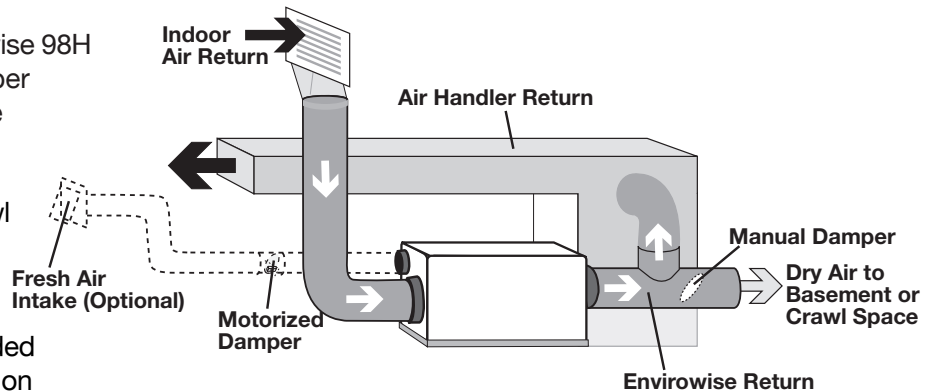

Recommended HVAC Ducting Installations

HVAC Return to HVAC Supply

The HVAC fan must be interlocked from the system control to turn on when the dehumidifier is in operation.

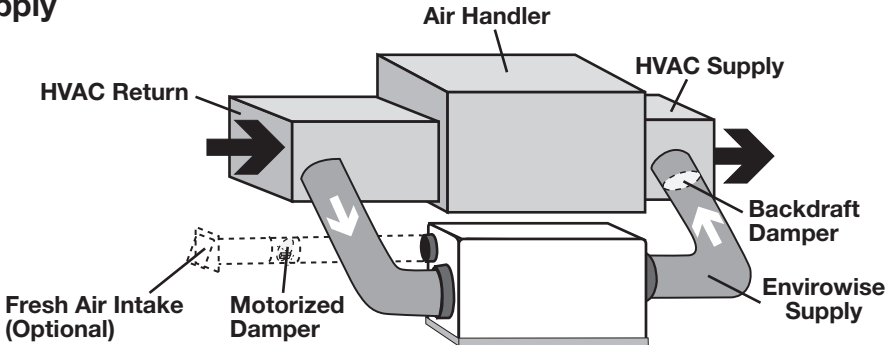

⚠ CAUTION!

DO NOT CONNECT WITH A STATIC PRESSURE GREATER THAN OR EQUAL TO +0.5 WG. CONTACT TECHNICAL SUPPORT AT (800) 533-7533 FOR ADDITIONAL DETAILS.

GENERAL SET UP

No Existing Ductwork Installation

When installing the Envirowise 98H in a structure that does not have a forced air HVAC system, a single return for the Envirowise 98H should be installed in a central location.

Install an insulated duct from outside to the 6" collar of the Envirowise 98H to provide fresh air ventilation (optional).

The supply of the Envirowise 98H should be ducted to remote areas of the structure such as bedrooms, living room, den, etc. Be sure to utilize multiple rooms to allow air inside the structure to properly circulate. Proper air distribution is important to ensure even humidity control and heat distribution throughout the structure.

A 6" diameter duct is recommended for branches to bedrooms. An 8" diameter duct is recommended for branches to larger areas.

- DO NOT locate the return in a bathroom or kitchen.
- DO NOT locate the supply in rooms where doors may be closed.
- Control should be located remotely from the dehumidifier and placed in a central location.

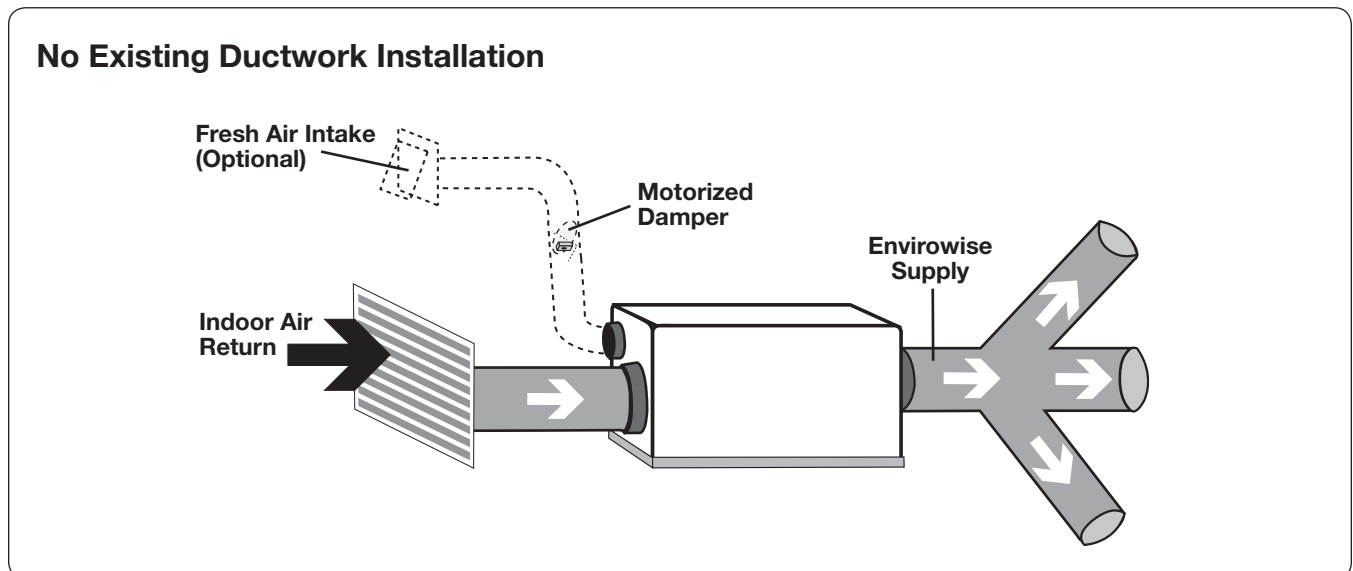

Recommended Closet Installation

Due to space limitations, a closet installation may require additional considerations. Locate the dehumidifier under or next to the HVAC system as space allows. A passive vent or louver door is required to allow air to be pulled in from the living space.

- No inlet duct is required. Air is pulled through the passive vent or louver door from the living space.
- Install an insulated duct from outside to the 6" collar of the Envirowise 98H to provide fresh air ventilation (optional).
- Control should be located remotely from the dehumidifier and placed in a central location.
- Where outlet space is restricted, the outlet duct collar is optional or vertical flow through may be preferred.

⚠ WARNING!

WHEN INSTALLING THE DEHUMIDIFIER AS PART OF A COMBUSTION TYPE HVAC SYSTEM (GAS, OIL, PROPANE, ETC.), FOLLOW ALL LOCAL AND NATIONAL BUILDING AND SAFETY CODES.

Central Return to HVAC Supply

Duct the supply of the Envirowise 98H to the supply of the existing HVAC system with a backdraft damper.

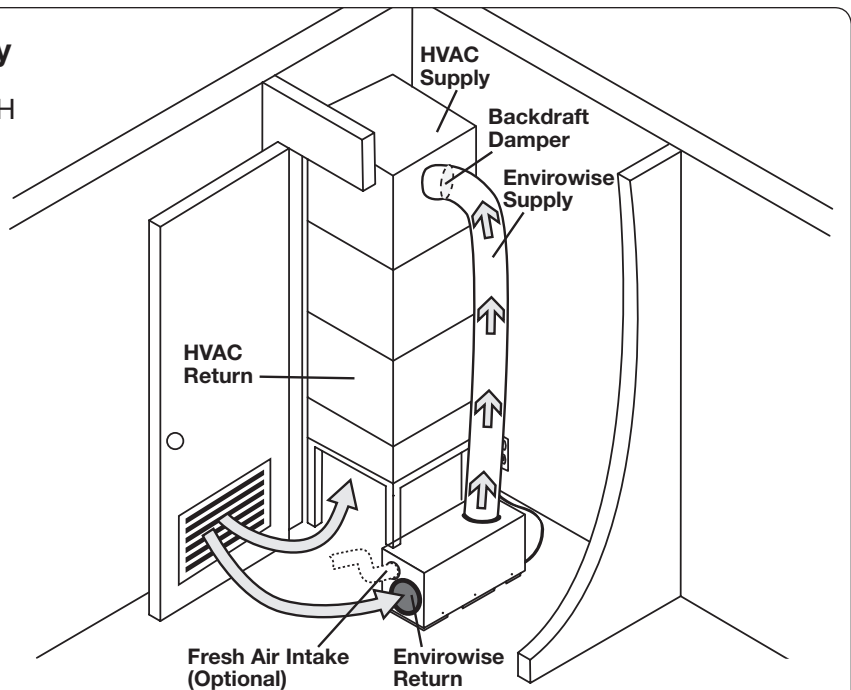

GENERAL SET UP

Fresh Air Ventilation

Fresh Air Ventilation is Optional.

Fresh air may be brought into the structure by connecting an insulated duct from outside the structure to the 6" inlet of the Envirowise 98H. A ventilation control (optional: D30 or Connected Control with ventilation software) is needed to program the time and frequency that the unit introduces outside air. The time and frequency of ventilation should be based on the size and occupancy of the residence (see table on next page).

- The fresh air ventilation duct should be connected to the 6" round collar on the front of the Envirowise 98H.
- An insulated 6" diameter duct provides up to 75 CFM of outside air.
- If a motorized damper is not being used, fresh air is controlled by the manual damper in the 6" collar of the Envirowise 98H.
- Performance of the Envirowise 98H can be impacted by inside and outside air conditions.
- When a 6" motorized damper is used, a digital control is required.
- It may be necessary to use 8" duct work if additional fresh air is required (up to 130 cfm).
- In cold climates or at times when the dew point is low, ventilation can be used to dehumidify the structure, making the Envirowise 98H capable of year-round drying.

Fresh Air Ventilation With Dehumidifier Off and Fan Only Operation

Outside air mixes with the dehumidifier's return air before being supplied to the home. Outside temperature, inside temperature and relative humidity will impact the combined outlet air conditions.

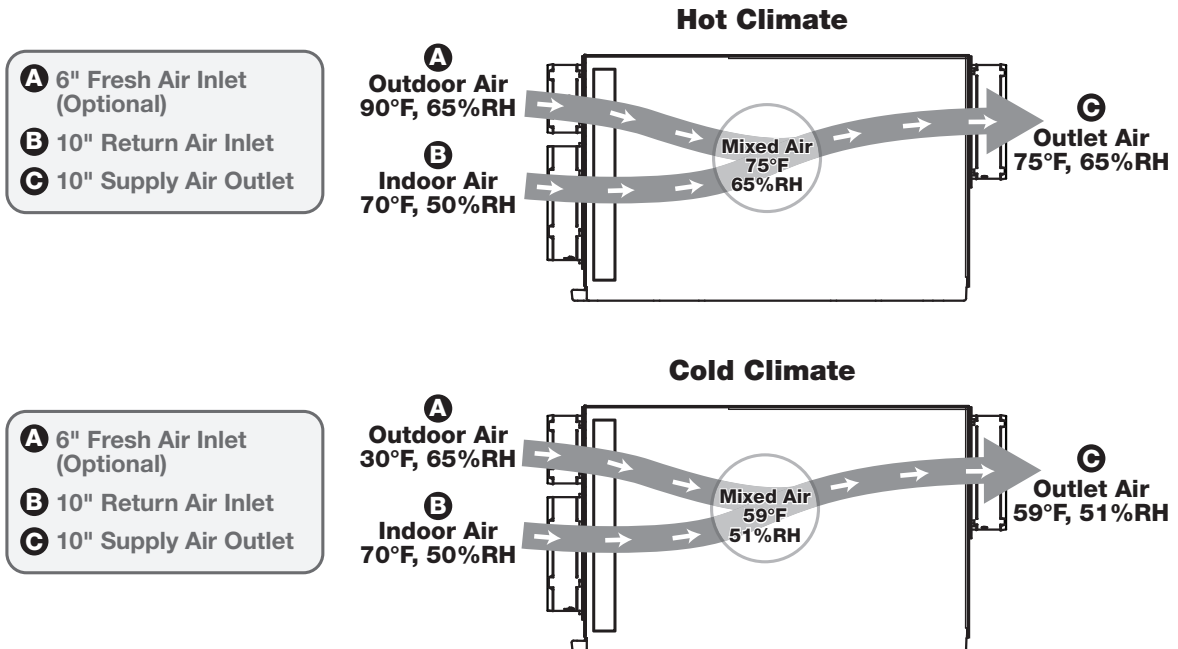

Note: Temperature and relative humidity may vary depending on duct distribution scheme.

Determine Ventilation Requirements

The MINIMUM ventilation requirement is calculated using ASHRAE 62.2-2016. Use one or both of the options below to determine your ventilation requirement. Follow all local and national building and safety codes.

Option 1: Calculating Airflow Requirement Using ASHRAE 62.2-2016 Airflow Equation

ASHRAE Airflow in CFM = [House Area in Sq.Ft. x 0.03] + [(Number of Bedrooms + 1) x 7.5]

NOTE: Use 'Number of Bedrooms + 1' or 'Number of Occupants', whichever is larger.

Example 1: Number of Bedrooms + 1
 1800 square foot house with 3 bedrooms, 4 occupants = [1800 X 0.03] + [(3+1) X 7.5] = 84 CFM

Example 2: Number of Occupants
 1800 square foot house with 3 bedrooms, 5 occupants = [1800 X 0.03] + [5 X 7.5] = 91.5 CFM

Record the required CFM _____

Option 2: Calculating Airflow Requirement Using Table 4.1 from ASHRAE 62.2-2016

Ventilation Air Requirements, CFM

Floor Area (ft ²)	Number of Bedrooms				
	1	2	3	4	5
< 500	30	38	45	53	60
501 - 1000	45	53	60	68	75
1001 - 1500	60	68	75	83	90
1501 - 2000	75	83	90	98	105
2001 - 2500	90	98	105	113	120
2501 - 3000	105	113	120	128	135

Table 4.1 from ASHRAE 62.2-2016

Record the required CFM _____

CONTROLS

A control must be used with the Envirowise 98H. Nexia Connected Controls, like the 824, 850 and 1050, have built-in dehumidification software that allows homeowners to monitor and control relative humidity and proper ventilation levels in their home. Nexia Controls are available from your installing contractor. The diagrams below show how the 98H connects to Nexia Controls.

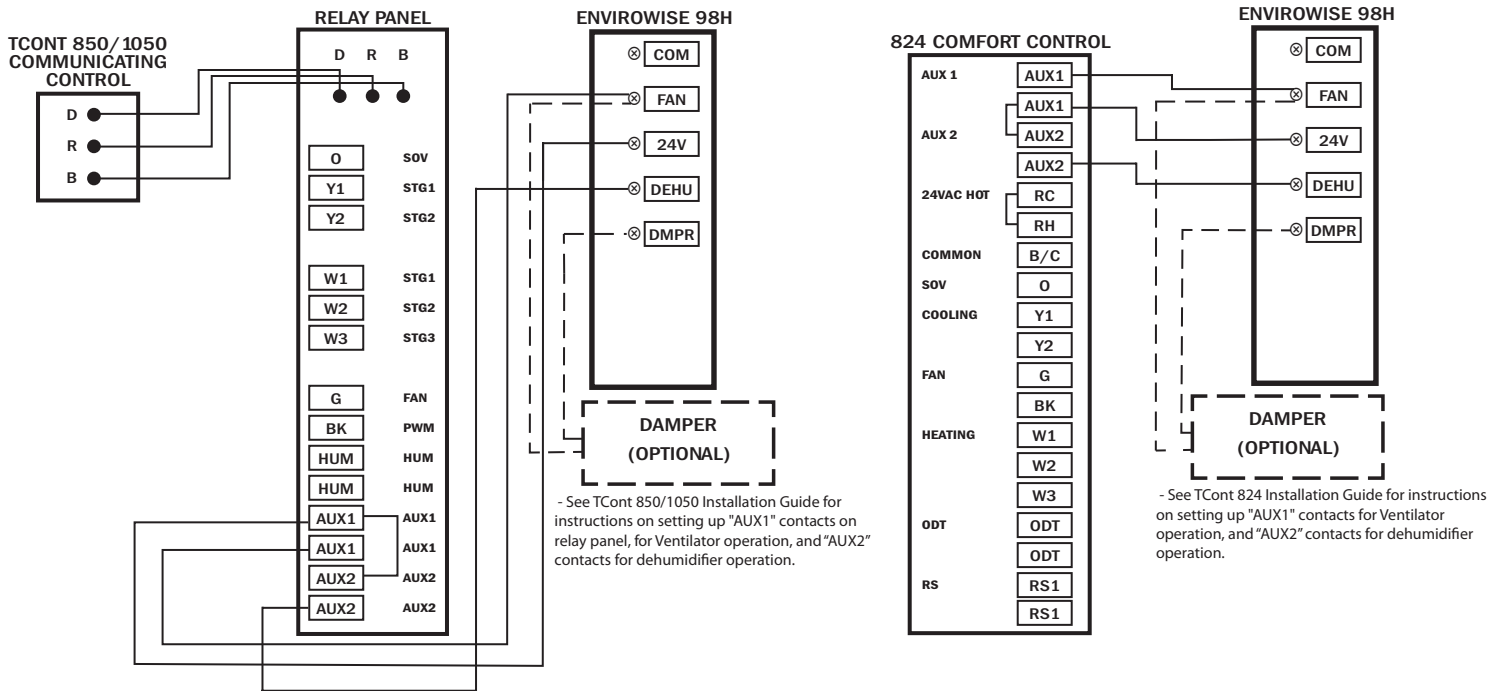

A control must be used with the Envirowise 98H. Envirowise offers the D30 proprietary control. The D30 allows homeowners to monitor and control relative humidity and proper ventilation levels in their home. This control is also available with a remote sensing option.

Note: The D30 is sold as an accessory and can be purchased through your installing contractor.

Envirowise D30 Digital Control

- **Central Fan Integration** – Operates HVAC fan with dehumidifier operation.
- **A/C Sensor** – Automatically activates or deactivates the dehumidifier when the air conditioner runs.
- **High Temperature Cut-Out** – Disables dehumidifier operations if household temperature reaches the cut-out setpoint.
- **Dry-Out Cycle Timer** – Automatic fan cycling to ensure dry and clean coils.
- **Auto Reboot** – Resumes operation with prior settings in the event of power failure.

See D30 manual for detailed instructions.

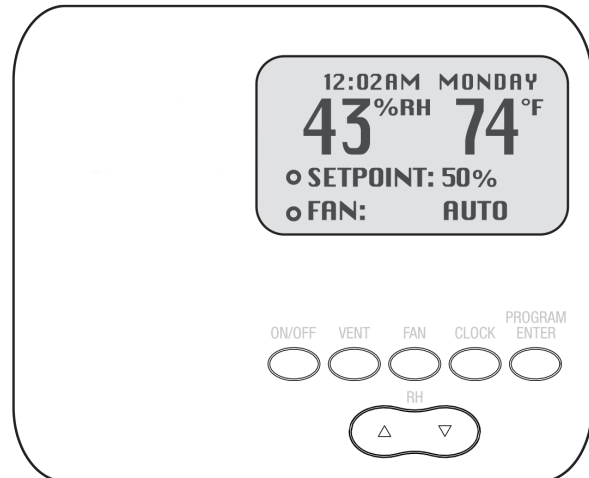

Wiring Controls

⚠ CAUTION!

DO NOT ALLOW THE 24V TERMINAL FROM THE ENVIROWISE 98H TO CONTACT THE COM/DMPR TERMINALS FROM THE ENVIROWISE 98H OR DAMAGE TO THE TRANSFORMERS WILL RESULT.

DO NOT CONNECT THE COM TERMINAL TO THE CONTROL IF THE OPTIONAL DAMPER IS NOT USED OR DAMAGE TO THE TRANSFORMER WILL RESULT.

Circuit Breaker

To prevent damage to the 24 volt control transformer, the Envirowise 98H comes with a resettable circuit breaker. Check wiring for any electrical short and repair before resetting breaker. Resetting the circuit breaker without correcting the electrical short may result in transformer damage. Be sure to check the electrical schematic in this manual or inside the access panel of the Envirowise 98H before making any control connections. The reset button for the circuit breaker can be found on the back of the unit.

Control Connections

The control and the screw terminals on the Envirowise 98H are labeled to prevent confusion. Depending on the control, some of the screw terminals on the Envirowise 98H may not be used. Be sure to consult the electrical schematic in this manual or inside the access panel of the Envirowise 98H before making control connections.

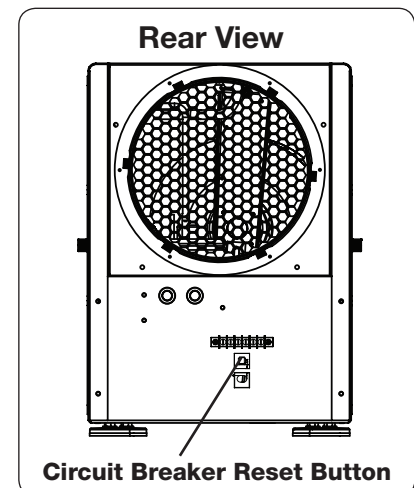

CONTROLS

Envirowise 98H Wired to the D30 Digital Control (Part # E4037893)

Envirowise 98H Wired to a 2-Wire Thermal-Mechanical Dehumidistat

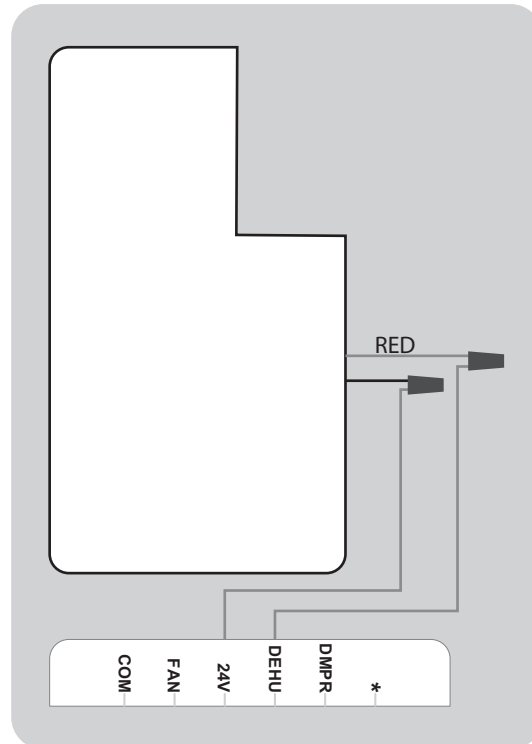
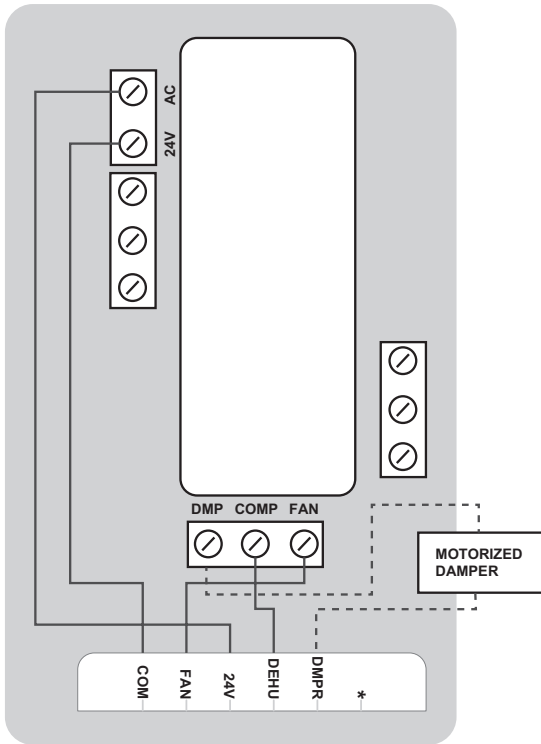

A 24V control must be used with the Envirowise 98H.

Terminal Block Control Operation:

COM	24VAC Power Transformer Neutral Side
FAN	Fan Control
24V	Transformer High Side
DEHU	Dehumidification (Fan and Compressor) Control
DMPR	24VAC Power Transformer Neutral Side
*	Spare Terminal (Open)

Between the COM/DMPR lead and the 24V TERMINAL is a 40VA transformer. This low voltage power source powers the relay coils which control the fan and compressors. This 24VAC transformer can also be used to power HVAC accessories external to the dehumidifier.

Compressor ON / Fan ON	Make contact between 24V and DEHU terminals
Compressor OFF / Fan ON	Make contact between 24V and FAN terminals
Power HVAC Accessory	Connect the accessory to the DMPR (or COM) and 24V terminals

NOTE: 18 gauge wire needed between the Envirowise 98H dehumidifier and the external control.

FILTER INSTRUCTIONS

The Envirowise 98H is equipped with a MERV-11 air filter. A MERV-14 filter and filter housing are available as an optional accessory. Contact your installing contractor for more information. DO NOT operate the unit without the standard MERV-11 filter. Operating the unit with no filter in place will damage the coil and may void the factory warranty.

⚠ CAUTION!

MAKE SURE UNIT IS OFF BEFORE CHANGING THE FILTER.

Changing the Filter

For greatest filtration and efficiency of the Envirowise 98H, it is recommended the air filter be replaced every three to six months with a MERV-11 filter.

Step 1: Pull back slide latch to swing filter door open.

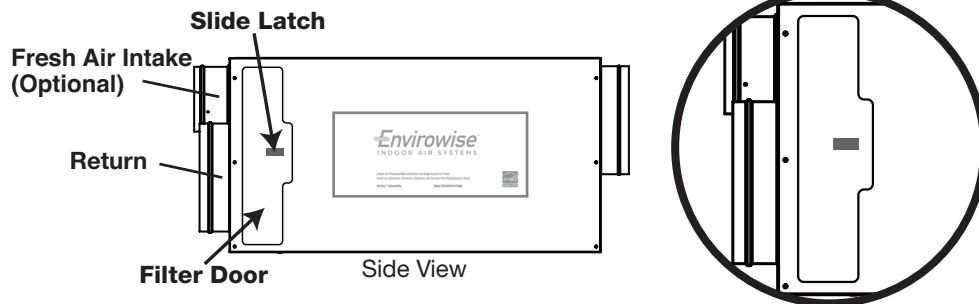

Step 2: Remove the filter by gently pulling it straight out of the unit. Insert new filter by gently pushing it straight into the unit. Make sure the AIR FLOW arrow on the filter is pointing into the unit.

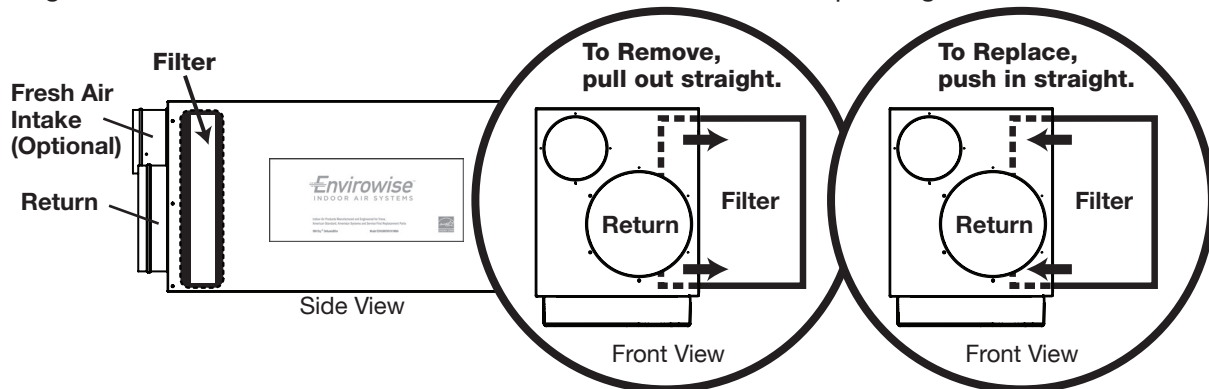

Step 3: Insert filter door into tabs and swing door closed to lock the latch into place.

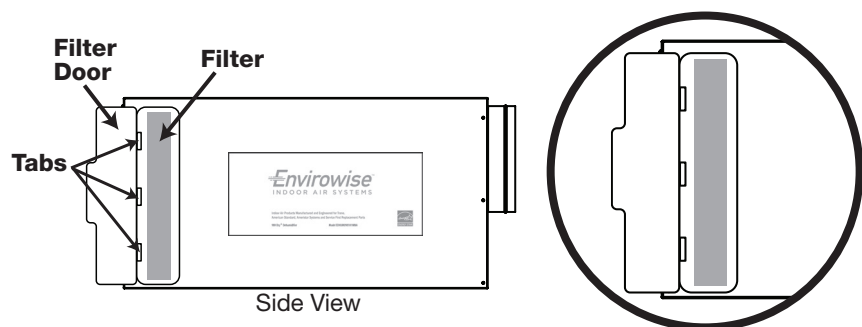

OPTIONAL ACCESSORIES

E4037893	D30 Control
E4037897	D30 Control W/ Remote
E4037876	MERV-11 Filters 4-Pack
E4037883	MERV-11 Filters 12-Pack
E4037887	MERV-14 Filter Housing
E4037891	MERV-14 Filters 3-Pack
E4037903	Pump Kit
E4037869	Hang Kit
E4037861	6" Motorized Damper
E4037907	6" Inlet Hood
E4037865	10" Gravity Damper

Troubleshooting

⚠ CAUTION!

TROUBLESHOOTING SHOULD BE PERFORMED BY A QUALIFIED HVAC TECHNICIAN.

Symptom	Possible Reason	Troubleshooting Procedure
Neither fan nor compressor running. Dehumidification is being called for.	<ol style="list-style-type: none"> 1. Dehumidifier unplugged or no power to outlet. 2. Humidity control set too high. 3. Loose connection in internal or control wiring. 4. Defective compressor relay. 5. Defective control transformer. 	<div style="border: 1px solid black; padding: 5px; margin-bottom: 10px;"> <p>⚠ WARNING!</p> <p>ELECTRICAL SHOCK HAZARD: ELECTRICAL POWER MUST BE PRESENT TO PERFORM SOME TESTS. THESE TESTS SHOULD BE PERFORMED BY A QUALIFIED SERVICE PERSON.</p> </div> <p>Troubleshooting Procedure for Control Related Issues</p> <p>This method of diagnosis will test the 3 main components of the control circuit individually to indicate any potential problems. This is to be used when the control will not activate the main unit.</p> <ol style="list-style-type: none"> 1. Detach field control wiring connections from the terminals on the main unit. 2. Connect the 24V and FAN terminals together; only the fan should run. Disconnect the terminals. 3. Connect the 24V and DEHU terminals together; fan and compressor should run. Disconnect the terminals. 4. If this test works, the main unit is working correctly from a control standpoint. 5. Reconnect field control wiring to the terminals on the main unit. 6. Remove the control panel cover and detach the field wiring from the control connections. 7. Connect the 24V and FAN terminals together; only the fan should run. Disconnect the terminals. 8. Connect the 24V and DEHU terminals together; fan and compressor should run. Disconnect the terminals. 9. If this test works, then the field control wiring is ok. 10. If the problem persists, then the control is most likely faulty.
Compressor is not running. Dehumidification is being called for. Fan is running.	<ol style="list-style-type: none"> 1. Defective compressor run capacitor. 2. Loose connection in compressor circuit. 3. Defective compressor overload. 4. Defective compressor. 5. Defrost thermostat open. 	
Compressor cycles on and off. Dehumidification is being called for.	<ol style="list-style-type: none"> 1. Low ambient temperature and/or humidity causing unit to cycle through defrost mode. 2. Defective compressor overload. 3. Defective compressor. 4. Defrost thermostat defective. 5. Dirty air filter(s) or air flow restricted. 6. Defective fan or relay. 	

Troubleshooting (Continued)

Symptom	Possible Reason	Troubleshooting Procedure
Fan is not running. Dehumidification or fan is being called for.	<ol style="list-style-type: none"> 1. Loose connection in fan circuit. 2. Obstruction prevents fan impeller rotation. 3. Defective fan. 4. Defective fan relay. 	<div style="border: 1px solid black; padding: 5px;"> <p>⚠ WARNING!</p> <p>ELECTRICAL SHOCK HAZARD: ELECTRICAL POWER MUST BE PRESENT TO PERFORM SOME TESTS. THESE TESTS SHOULD BE PERFORMED BY A QUALIFIED SERVICE PERSON.</p> </div>
Low dehumidification capacity (evaporator is frosted continuously). Dehumidification is being called for.	<ol style="list-style-type: none"> 1. Defrost thermostat loose or defective. 2. Low refrigerant charge. 3. Dirty air filter(s) or air flow restricted. 4. Excessively restrictive ducting connected to unit. 	<p>Troubleshooting Procedure for Performance Related Issues</p> <p>This method of diagnosis is used to function check the internal components in the dehumidifier. This is to be used when a performance issue is suspected.</p>
No ventilation. Ventilation is being called for.	<ol style="list-style-type: none"> 1. Loose connection in ventilation control circuit. 2. Loose connection in damper power circuit. 3. Defective fresh air damper. 	<ol style="list-style-type: none"> 1. Set the humidity controller all the way to the most humid setting or off position – Did the unit shut off? 2. If yes, turn the fan setting to the ON position – does the fan start? 3. If fan starts, leave in the fan ON position and set the humidity all the way to driest setting. May have to wait 5 minutes for the compressor to start.
Dehumidifier removes some water, but not as much as expected.	<ol style="list-style-type: none"> 1. Air temperature and/or humidity have dropped. 2. Humidity meter and or thermometer used are out of calibration. 3. Unit has entered defrost cycle. 4. Dirty air filter(s) or air flow is restricted. 5. Defective defrost thermostat. 6. Low refrigerant charge. 7. Air leak such as loose cover or ducting leaks. 8. Defective compressor. 9. Restrictive ducting. 	<ol style="list-style-type: none"> 4. Listen for a distinct buzzing/humming sound of a compressor starting up – do you hear this noise? 5. If compressor is running and continues to run, after about 15 minutes you should feel a slight increase in air temperature being discharged out of the discharge air side of the unit. 6. If so, depending on your environmental conditions (temp/Rh%), you should see some water production out of the hose within 30 minutes or so. <i>(Note: If the room temperature is 55 degrees or below and/or in area of low relative humidity, the dehumidifier will produce little to no water.)</i> 7. Collecting the water removed in a 24 hour period will give a measurement of performance.

Troubleshooting (Continued)

⚠ CAUTION!

TROUBLESHOOTING SHOULD BE PERFORMED BY A QUALIFIED HVAC TECHNICIAN.

Symptom	Possible Reason	Troubleshooting Procedure
Control not powering dehumidifier.	<ol style="list-style-type: none"> 1. No power to dehumidifier. 2. 24 volt circuit breaker tripped or faulty transformer. 3. Loose or missing wire to the COMP Terminal on the humidity control. 4. Loose or missing wire to the DEHU Terminal on the unit. 5. Humidity control defective. 	<div data-bbox="836 556 1453 798" style="border: 1px solid black; padding: 5px;"> <h3>⚠ WARNING!</h3> <p>ELECTRICAL SHOCK HAZARD: ELECTRICAL POWER MUST BE PRESENT TO PERFORM SOME TESTS. THESE TESTS SHOULD BE PERFORMED BY A QUALIFIED SERVICE PERSON.</p> </div> <ol style="list-style-type: none"> 1. Verify power to the unit at power outlet. 2. Look for short in control wiring. 3. Check wire connections at control and unit. 4. Reset circuit breaker button on dehumidifier.



Ingersoll Rand (NYSE:IR) advances the quality of life by creating comfortable, sustainable and efficient environments. Our people and our family of brands—including Club Car®, Ingersoll Rand®, Thermo King® and Trane®—work together to enhance the quality and comfort of air in homes and buildings; transport and protect food and perishables; and increase industrial productivity and efficiency. We are a global business committed to a world of sustainable progress and enduring results



ingersollrand.com

Ingersoll Rand has a policy of continuous product and product data improvements and reserves the right to change design and specifications without notice. We are committed to using environmentally conscious print practices.

18-HE103D1-1A-EN (JUL 2018)
Supersedes (NEW)

©2018 Ingersoll Rand | all rights reserved