

AccuLink™ Platinum 850 Communicating Connected Control ACONT850 Installation Guide



ALL phases of this installation must comply with NATIONAL, STATE AND LOCAL CODES



IMPORTANT — This Document is customer property and is to remain with this unit.

These instructions do not cover all variations in systems or provide for every possible contingency to be met in connection with the installation. Should further information be desired or should particular problems arise which are not covered sufficiently for the purchaser's purposes, the matter should be referred to your installing dealer or local distributor.

Contents

1. Safety	2	6.9 Quiet Mode.....	15
2. Product Specifications	3	6.10 Fan Mode	15
3. General Information	3	6.11 Air Cleaner Mode	15
3.1 Overview	3	7. Advanced Operation	16
3.2 Contents.....	3	7.1 Control Response Rate	16
3.3 Accessories.....	3	7.2 Dehumidification.....	16
4. Installation	4	7.3 Dehumidifier Operation	16
4.1 Location.....	4	7.4 Dual Fuel Operation	16
4.2 Network Connections	4	7.5 Lockouts	17
4.3 Mounting	4	7.6 Humidifier Operation	18
4.4 Wiring.....	5	7.7 Recovery	18
4.5 Field Wiring Connection Diagrams.....	6	7.7.1 Aggressive Recovery	18
5. System Setup	7	7.7.2 Heating Aggressive Recovery	18
5.1 Power-Up Sequence	7	7.8 Ventilation Operation.....	18
5.2 Guided Setup Wizards	7	7.9 Warm Air Discharge	18
5.3 Smart Optimization.....	7	7.10 Wet Heat (Hydronic) Operation	18
5.4 Installer Setup Screens	8	8. Diagnostic Tools	19
5.4.1 Group 1 Standard Settings.....	8	8.1 Test Modes.....	19
5.4.2 Group 2 Equipment Settings	8	8.1.1 Non-Variable Speed	19
5.4.4 Group 3 Sensor Settings.....	9	8.1.2 Variable Speed	19
5.4.3 Group 4 Accessories Settings.....	9	8.2 Save Logs	20
5.4.5 Group 5 Comfort Settings	10	8.3 Diagnostics.....	20
5.4.6 Group 6 Airflow Settings.....	11	8.3.1 Alerts.....	20
5.4.7 Group 7 Lockout Settings.....	12	8.3.2 Summary Table	20
5.5 Service Reminders.....	12	8.4 History.....	20
5.6 Dealer Code	12	8.5 System Report	20
5.7 Software Updates.....	12	8.5.1 Non-Variable Speed Screens.....	20
6. Basic Operation	13	8.5.2 Variable Speed Screens.....	21
6.1 PI Control	13	8.6 Restore Factory Defaults.....	21
6.2 Load Value - Heating.....	13	9. Troubleshooting	22
6.3 Load Value - Cooling.....	13	10. Notices	23
6.4 Duty Cycles (non VSPD systems).....	13	10.1 FCC Notice.....	23
6.5 Overshoot Clamp	13	10.2 IC Notice	23
6.6 Stage Thresholds	14		
6.7 Stage Inhibits	14		
6.8 System Mode	15		

1. Safety

NOTE: Use 18-gauge color-coded thermostat cable for proper wiring. Shielded cable is not typically required.

Keep this wiring at least one foot away from large inductive loads such as Electronic Air Cleaners, motors, line starters, lighting ballasts and large distribution panels.

WARNING

This information is intended for use by individuals possessing adequate backgrounds of electrical and mechanical experience. Any attempt to repair a central air conditioning product may result in personal injury and/or property damage. The manufacturer or seller cannot be responsible for the interpretation of this information, nor can it assume any liability in connection with its use.

Failure to follow these wiring practices may introduce electrical interference (noise) which can cause erratic system operation.

All unused thermostat wire to be grounded at indoor unit chassis ground only. Shielded cable may be required if the above wiring guidelines cannot be met. Ground only one end of the shield to the system chassis.

WARNING

LIVE ELECTRICAL COMPONENTS!
During installation, testing, servicing, and troubleshooting of this product, it may be necessary to work with live electrical components. Failure to follow all electrical safety precautions when exposed to live electrical components could result in death or serious injury.

2. Product Specifications

SPECIFICATION	DESCRIPTION
Product Model	ACONT850AC52UAA
Product	850 Wi-Fi Connected Communicating Comfort Control
Size	5-1/2" x 3-3/8" x 1" (WxHxD)
Configurations	Heat Pump, Heat/Cool, Dual Fuel, Heat Only, Cooling Only
Maximum Number of Stages	5 Stages Heat, 2 Stages Cooling
Storage/Operating Temperature	-40°F to 175°F, 5% to 95% RH non-condensing
Input Power	24VAC
Power Consumption	7VA*
Wire Usage	18 AWG
Communications	AccuLink 3-Wire Connection
System Modes	Auto, Heating, Cooling, Off, Emergency Heat
Fan Modes	Auto, On, Circulate
Cooling Setpoint Temperature Range	60°F to 99°F, 1°F resolution
Heating Setpoint Temperature Range	55°F to 90°F, 1°F resolution
Indoor Temperature Display Range	-40°F to 122°F
Outdoor Temperature Display Range	-40°F to 140°F
Indoor Humidity Display Range	0% to 100%, 1% resolution
Minimum Cycle Off Time Delay	Compressor: 5 minutes, Indoor Heat: 1 minute

*On every application, 24VAC loads should be reviewed to be sure the indoor unit control power transformer is adequately sized.

3. General Information

3.1 Overview

The 850 Programmable Wi-Fi Control has a 4.3" color touch screen and offers a full-featured and easy-to-use interface. From individual daily schedules to remote access, the 850 is one of the most advanced Communicating Controls available.

3.2 Contents

- 1-Control
- 1-Sub-base
- 2-#6 18X1 Phillips slotted head mounting screws
- 2-#6x1 Nylon Drywall Anchors
- 1-Installation Guide
- 1-Quick Start Guide
- RJ-45 Holder and Screw
- 1-USB "On-the Go" Adapter Cable (Micro USB plug to Standard USB receptacle)

3.3 Accessories

- Wired Remote Indoor Sensor (ZZSENSAL0400AA)
- Wired Remote Outdoor Sensor (BAYSEN01ATEMPA)
- Relay Panel for 24v applications (BAY24VRPAC52D)

4. Installation

4.1 Location

The 850 is designed for installation in climate controlled living spaces. Place the unit in a central location with good circulation.

For proper temperature sensing, avoid exposing the 850 to heat radiated from lamps, sun light, fireplaces or any other radiant heat source.

Avoid locations close to windows, behind doors or alcoves with poor air circulation, adjoining outside walls, or doors that lead to the outside.

Select a location that prevents the 850 from being directly exposed to air currents from supply registers or ceiling fans.

Mount the Control on a section of interior wall that does not contain hot or cold water pipes or duct work.

Important: The 850 Control utilizes a 4.3" color touch screen. This screen generates heat which is vented out the top of the Control utilizing natural convection. If an air source is directed at or from above, heat from the screen can be trapped within the Control and can cause the indoor temperature to be biased. (Refer to Figure 1 on page 4.)

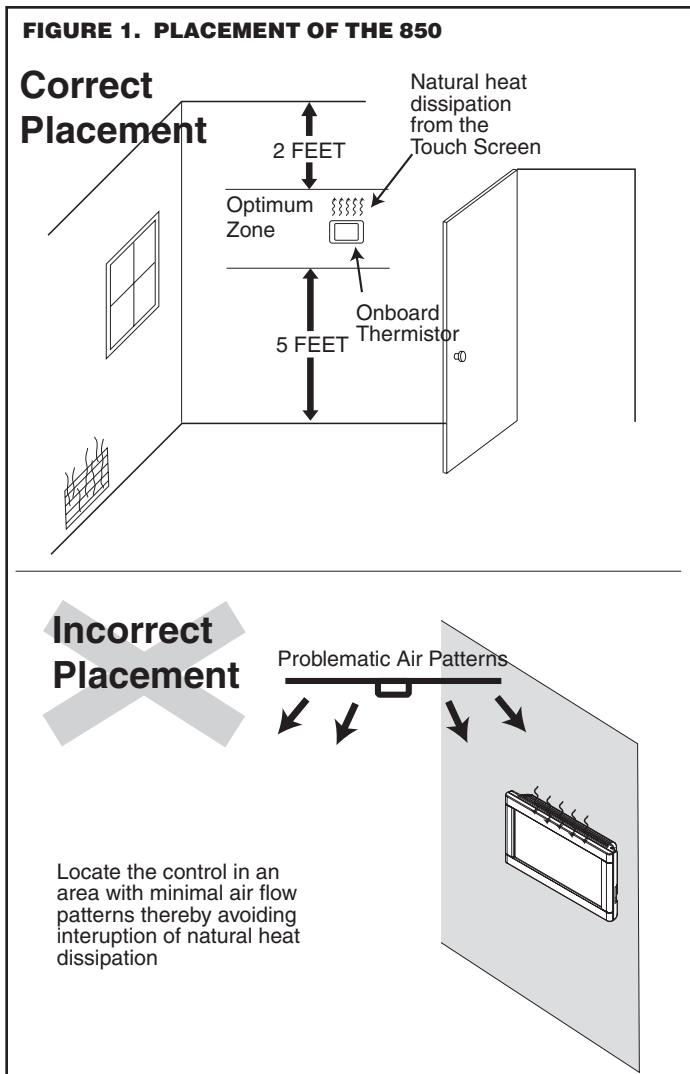

4.2 Network Connections

To take advantage of the full range of features on the 850 Control, it should be connected to the Internet. This is possible using either a wireless or a wired connection.

Wireless Connections

If the 850 Control will be connected to the Internet using the built-in wireless feature, choose a mounting location that ensures adequate signal strength from the Internet router.

Tips to Help Maximize Signal Strength:

- Do not mount the Control more than 30 feet from the wireless router
- There should be no more than three interior walls between the Control and the router.
- Do not mount the Control in areas where electromagnetic emissions from other devices, appliances or wiring can interfere with the Control's communication. (i.e. wireless phones, security systems, wireless Internet cameras).
- Do not mount the Control in recessed areas, near metal objects, or near structures. (i.e. doors, appliances, entertainment centers or shelving units).
- Do not mount the Control closer than 2 inches to any pipes, duct work, or other metal obstructions.
- Do not have metal obstructions, concrete or brick walls between the Control and the router.

Refer to the 850 User Guide for additional information on connecting the 850 to the Internet.

Wired Connections

The 850 Control may be connected to the Internet using its built-in RJ-45 connector. When using a wired connection, verify that a CAT 5 or better Ethernet cable with a male RJ-45 connector is present from the router to the Control.

4.3 Mounting

Follow these steps to mount the 850 Control to the wall.

1. Turn OFF all power to heating and cooling equipment.
2. If an existing thermostat is being replaced:
 - a. Remove the existing thermostat from the wall.
 - b. Record color and terminal marking of each wire.
 - c. Disconnect the wires from the existing thermostat being careful not to allow them to fall back into the wall.
3. Carefully pry the Sub-base away from the 850 Control using a small flat-blade screwdriver. Note that the tight fit is normal and ensures that the Control is held securely to the Sub-base when mounted on the wall.
4. Route the wires through the opening on the Sub-base.
5. If using a wired Internet connection, route the Ethernet cable through the opening.

6. Place the Sub-base against the wall in the desired location and mark the wall through the mounting holes. If you are using a wired Internet connection, be sure to mark the cutout for the RJ-45 connector (see Figure 2 on page 5).
7. Drill the holes in the wall where marked.

If you are using a wireless Internet connection, skip to step 9.

8. When using a wired Ethernet connection, follow these step and refer to Figure 3 on page 5.
 - a. With the Sub-base and RJ-45 holder oriented as shown, press the holder into the Sub-base.
 - b. Slide the holder to the right so it snaps in place.
 - c. Secure the holder with the provided screw.
 - d. Insert the RJ-45 Connector into the RJ-45 holder until it snaps into place.
9. Mount the Sub-base to the wall using included mounting screws and drywall anchors. An optional mounting hole is available for more secure mounting, if needed. Make sure all wires extend through the hole in the Sub-base see Figure 4 on page 5.

4.4 Wiring

1. Adjust the length and position of each wire to reach the proper terminal on the connector block of the Sub-base. Strip 1/4" of insulation from each wire. Do not allow adjacent wires to short together when connected.
2. Match and connect control wires to the proper terminals on the connector block. Refer to Field Wiring Diagrams included in this document.
3. Push excess wire back into the wall and seal the hole to prevent air leaks. **NOTE: Air Leaks in the wall**

FIGURE 2. MARK THE MOUNTING HOLES

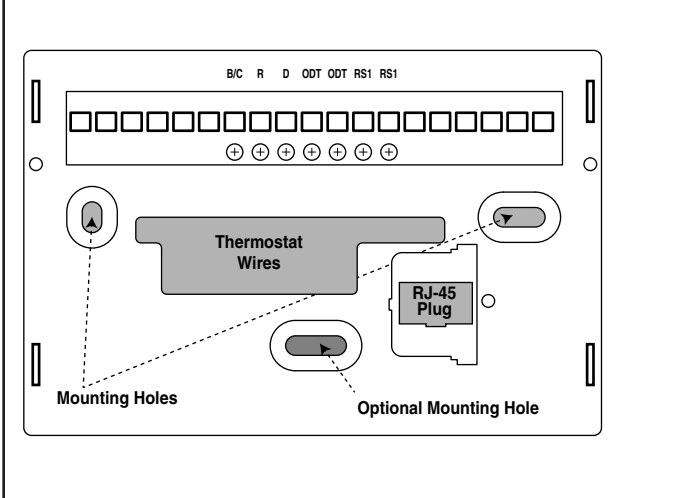

behind the Control can cause improper operation.

4. Attach the Control to the Sub-base.
5. Turn ON power to the heating and cooling equipment.

FIGURE 3. ATTACH RJ-45 HOLDER TO SUB-BASE

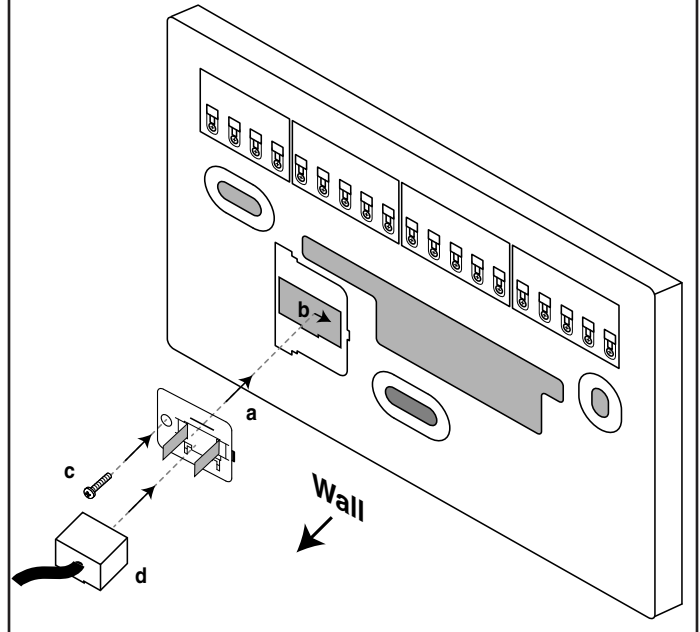
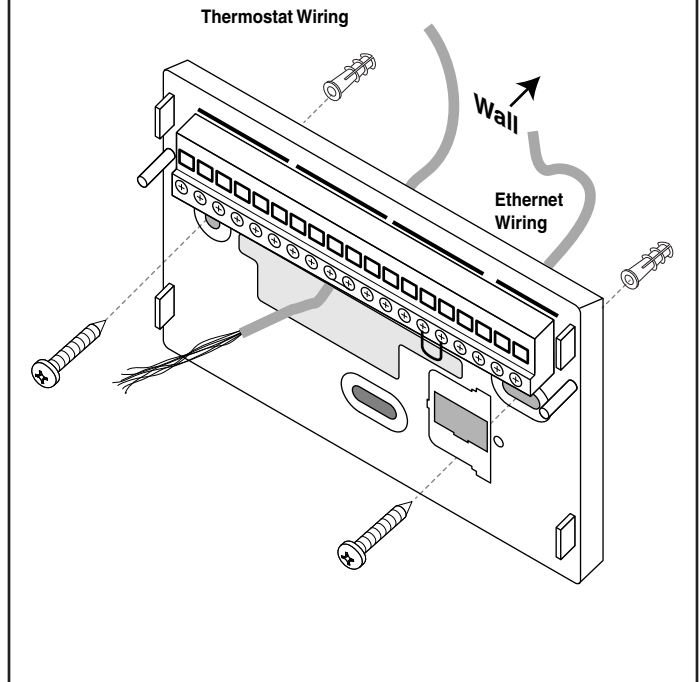
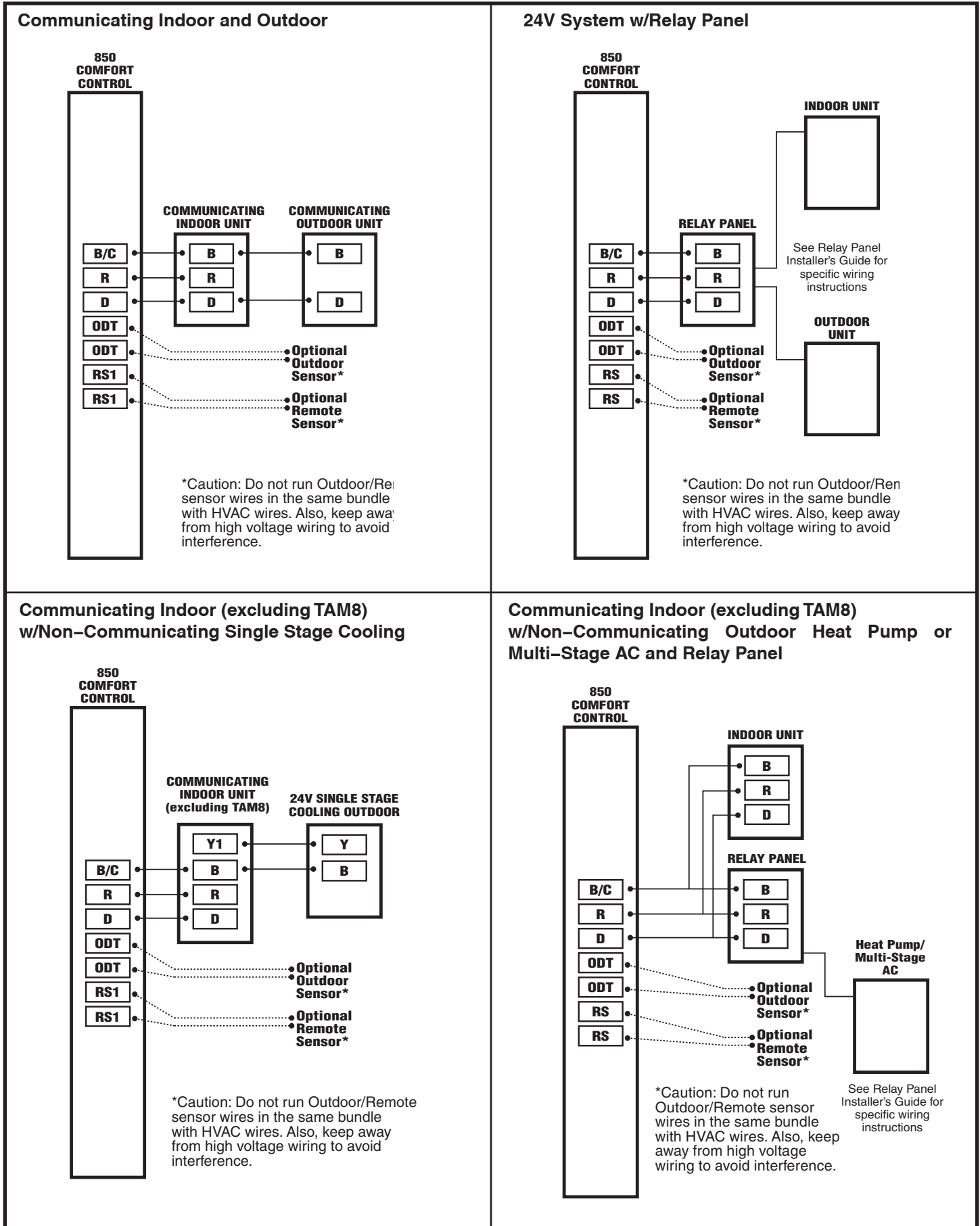
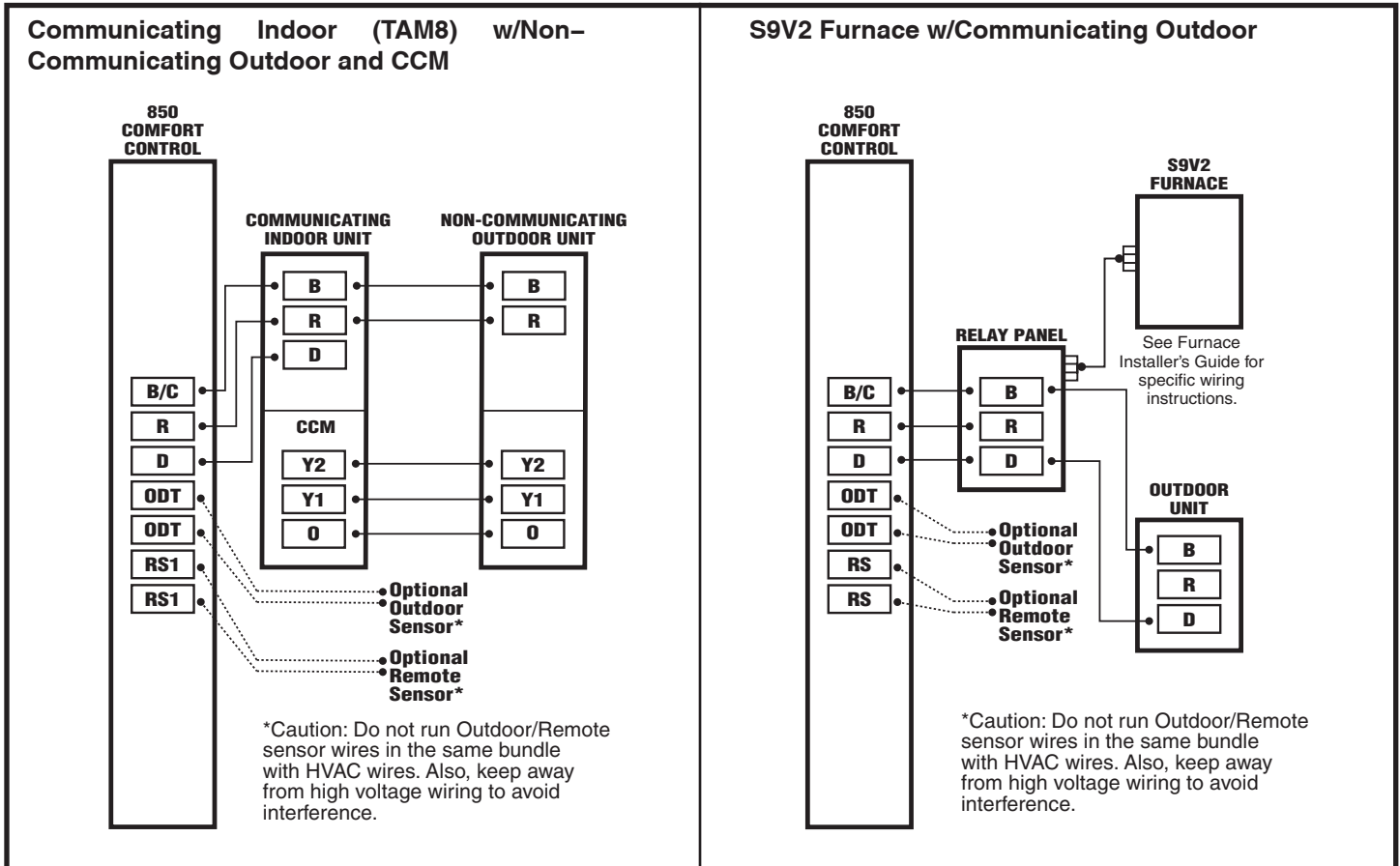

FIGURE 4. MOUNT THE SUB-BASE TO THE WALL



4.5 Field Wiring Connection Diagrams





5. System Setup

5.1 Power-Up Sequence

When the 850 Control is connected to the Sub-base, the Control initiates a 90-120 second power-up sequence. During the power-up sequence, the Screen Calibration option is available for five seconds (Screen Calibration is available for five minutes if the screen has never been calibrated and following a Restore Factory Defaults command).

If the screen is not pressed within five minutes, the Control will default to previously stored Screen Calibration settings. The 850 Control is factory calibrated and can be recalibrated at any time by rebooting the Control.

Note: Temperature display may be inaccurate until the 850 Control acclimates to ambient room conditions, which may take up to one hour.

5.2 Guided Setup Wizards

The 850 Control features two Setup Wizards, the Installation Wizard and the User Setup Wizard. The Installation Wizard guides installers through the installation and configuration process, and the User Step Wizard guides Homeowners through user-configurable settings.

Installation Wizard

The Installation Wizard appears when the 850 Control is powered on for the first time, when the Restore Factory Defaults function is invoked (Home>Menu>Service>Technician Access>Proceed>Restore Factory Defaults), and when it is selected directly (Home>Menu>Service>Technician Access>Proceed>Installation Wizard).

By following the navigational steps and screen prompts, installer's are guided through the Time and Date, Installer Setup (see "5.4 Installer Setup Screens" on page 8 for detailed descriptions of each of the Installer Setup Screens), Reminders and Dealer Code configuration menus. Each of these menus can be individually accessed after completing the Installation Wizard.

User Setup Wizard

The User Setup Wizard is accessed navigating to Home>Menu>Settings>User Setup Wizard. By following the navigational steps and screen prompts, homeowners are guided through the Display, Schedules, Guided Schedule, Network, Nexia and Weather configuration screens. Each of these menus may also be accessed individually. Refer to the User Guide for detailed information on user settings.

5.3 Smart Optimization

The 850 Control is equipped with Smart Optimization. By executing a series of blower tests, Smart Optimization will customize the 850 Control to each unique environment and increase the accuracy of the sensed indoor temperature and overall system performance.

Smart Optimization is enabled by default and will automatically execute approximately 18 hours after initial power up. Smart Optimization takes 90 minutes to complete and during the process, heating and cooling operations are disabled. The screen will indicate that the 850 Control is in

Smart Optimization mode.

To delay Smart Optimization for an additional 18 hours, touch the 850 Control Screen and hold for five seconds.

To disable Smart Optimization altogether, navigate to Home>Smart Optimization and select Disable and press Apply.

To enable Smart Optimization, navigate to Home>Smart Optimization and select Enable and press Apply. Smart Optimization will execute in approximately 18 hours.

To manually trigger Smart Optimization, first disable, then re-enable the feature.

INSTALLATION WIZ-ARD MENU ITEMS	DESCRIPTION
Date and Time	Set the current date, time and select whether Daylight Savings Time is on or off.
Installer Setup	Configure the basic equipment components installed and customize how the control operates. See Sections 5.4.1 through 5.4.7 for detailed information on installer setup options.
Service Reminders	Various service reminders can be enabled on the 850 control based on the system configured. Reminder options are System, Filter, Ventilation, UV Light and Humidifier. The frequency of each reminder can be selected based on calendar or run time days.
Dealer Identification Code	The dealer identification code is used to populate the Dealer Contact Information and associate this device with a Nexia Dealer Portal account. Enter the primary phone number of the dealership to activate this feature. Only controls connected to the Internet will auto-populate the dealer information.

5.4 Installer Setup Screens

From the Installer Setup screens, individual parameters are configured and modified. Use the up and down arrows to scroll through the groups of settings. To change a setting contained in a particular group, press Edit and press Next to navigate to the desired setting. Press Save to save changes or Exit to discard changes.

5.4.1 Group 1 Standard Settings

MENU ITEM	OPTIONS [DEFAULT]	DESCRIPTION
Outdoor Unit Type	None, Cooling Only, Heat Pump	Select the type of outdoor unit installed
Outdoor Unit Stages	Single Stage, Two Stage, Variable	Select the number of outdoor unit stages
Compressor Type	Single Compressor Two Stage, Two Compressor Two Stage	Select the compressor type for multi-stage outdoor units
Indoor Unit Type	Gas/Oil, Electric, Hydronic	Select the type of indoor unit installed
Indoor Heat Stages	1, 2, 3, Modulating	Select the number of indoor heat stages
Indoor Blower Type	Non-Variable, Variable	Select the indoor blower type (Constant Torque motors are considered non-variable speed)

5.4.2 Group 2 Equipment Settings

MENU ITEM	OPTIONS [DEFAULT]	DESCRIPTION
Compressor Cooling Cycles Per Hour	2 - 6 Cph [3]	Select # of cycles per hour during cooling operation
1st Stage Compressor Cooling Cycles Per Hour	2 - 6 Cph [3]	Select # of cycles per hour during 1st stage cooling operation
2nd Stage Compressor Cooling Cycles Per Hour	2 - 6 Cph [3]	Select # of cycles per hour during 2nd stage cooling operation
Compressor Heating Cycles Per Hour	2 - 6 Cph [3]	Select the minimum runtime (MRT) of stage 1 indoor heat
1st Stage Compressor Heating Cycles Per Hour	2 - 6 Cph [3]	Select the minimum runtime (MRT) of stage 2 indoor heat
2nd Stage Compressor heating Cycles Per Hour	2 - 6 Cph [5]	Select the minimum off time (MOT) for indoor heat operation
Indoor Heater Cycles Per Hour	2 - 6 Cph [5]	Select # of cycles per hour during indoor heat operation
1st Stage Indoor Heat Cycles Per Hour	2 - 6 Cph [5]	Select # of cycles per hour during 1st stage indoor heat operation
2nd Stage Indoor Heat Cycles Per Hour	2 - 6 Cph [5]	Select # of cycles per hour during 2nd stage indoor heat operation
3rd Stage Indoor Heat Cycles Per Hour	2 - 6 Cph [5]	Select # of cycles per hour during 3rd stage indoor heat operation

5.4.4 Group 3 Sensor Settings

MENU ITEM	OPTIONS [DEFAULT]	DESCRIPTION
Select Outdoor Temperature Sensor	No ODT Sensor Thermostat ODT Sensor Communicating ODT Sensor Relay Panel ODT Sensor	Select whether an outdoor temperature sensor has been connected
Calibrate Outdoor Temperature Sensor	-5°F to 5°F	Calibrate the outdoor temperature sensor
Select Indoor Temperature Sensor	[Onboard IDT Sensor] Remote IDT Sensor	Select whether to use the onboard IDT or a remote IDT
Calibrate Indoor Temperature Sensor	-5% to 5%	Calibrate the onboard humidity sensor

5.4.3 Group 4 Accessories Settings

MENU ITEM	OPTIONS [DEFAULT]	DESCRIPTION
Filtration Type Installed	Air Cleaner, [Media Filter], Comm Air Cleaner Discovered	Select the filter type installed
Number Of Air Cleaners installed	[1], 2	Select the number of Comm Air Cleaners installed
Humidifier Installed	[No], Yes	Select whether a humidifier is installed
Humidifier Type	[Powered/Bypass], Steam	Select what type of humidifier is installed
Humidifier Control	[RH Control], Frost Control	Select how the humidifier will be controlled (Outdoor temperature sensor must be connected and enabled to allow this setting to be selected)
Humidifier Fan Action	[Humidify with Active Heat Call], Humidify without Active Heat Call	Select when the humidifier is allowed to operate (Humidification is disallowed during cooling mode or when the System Mode is Auto but the last call was cooling)
Airflow During Humidifier Only Mode	35% - [100%] 50	Select the desired airflow when the humidifier is operating without an active call for heat
UV Light Installed	[No], Yes	Select whether a UV Light is installed
Ventilation Installed	[No], Yes	Select whether a ventilation system is installed
Ventilation - Select Aux Contact	Aux 1, Aux 2	Select which set of aux contacts is controlling the ventilation system
Outdoor Temperature Ventilation Override	[Disable], Enable	Select whether an outdoor temperature override is allowed (Outdoor temperature sensor must be connected and enabled to allow this setting to be selected)
Ventilator Fan Action	[Ventilate with Blower], Ventilate without Blower	Select whether the indoor blower operates on a call for ventilation
Ventilation - Minimum Outdoor Temperature	-10°F - 50°F [0°]	Select the minimum outdoor temperature that ventilation is allowed
Ventilation - Maximum Outdoor Temperature	80°F - 110°F [100°F]	Select the maximum outdoor temperature that ventilation is allowed
Minimum Ventilation Runtime	0 - 60 Minutes [5 Minutes]	Select the minimum runtime per hour for ventilation system
Acculate Overridden Runtime	[No], Yes	Select whether the overridden ventilation runtime will be made up
Acculate Period	[4 hrs -recover based on OD conditions], 24 hrs - recover based on OD conditions, 4 hrs - recover to maintain min ventilation, 24 hrs - recover to maintain min ventilation	Select when to recover missed ventilation runtime due to outdoor conditions exceeding the minimum/maximum outdoor temperature for ventilation (The first two options will not meet AHRAE 62.2 standard for minimum ventilation requirements)
Dehumidifier Installed	[None], Yes	Select whether a dehumidifier is installed
Dehumidifier - Select AUX Contact	Aux 1, Aux 2	Select which set of aux contacts is controlling the dehumidifier
Run System Fan With Dehumidifier Request	[Yes], No	Select whether the indoor blower operates with a call for dehumidification

5.4.5 Group 5 Comfort Settings

MENU ITEM	OPTIONS [DEFAULT]	DESCRIPTION
Enable Dehumidification	[Enable], Disable	Select if enhanced dehumidification features are enabled. See section 7.2 Advanced Operation - Dehumidification for additional information.
Dehumidification Overcooling Limit - Degrees	[0°] - 3°F	Select the maximum amount of overcooling allowed when the indoor humidity exceeds the cooling target humidity setpoint. See section 7.2 Advanced Operation - Dehumidification for additional information.
Smart Continuous Fan	Enable, [Disable]	Select to enable or disable Smart Continuous Fan
Control Response Rate	[Normal], Fast	Select the response rate of the control. See section 7.1 Advanced Operation - Control Response Rate for additional information.
Aggressive Recovery > 2° Setpoint Change	Enable, [Disable]	Select whether the 10-minute staging inhibit is disabled (heating or cooling mode) with a setpoint change greater than 2°. See section 7.7.1 Advanced Operation - Aggressive Recovery for additional information.
Heating Aggressive Recovery by Outdoor Temperature	Enable, [Disable]	Select whether the 10-minute staging inhibit is disabled during heating mode when the outdoor temperature falls below the selected outdoor temperature (Outdoor temperature sensor must be connected and enabled to allow this setting to be selected)
Heating Aggressive Recovery Setting	0° - 70°F [40°F]	Select the outdoor temperature for Heating Aggressive Recovery
Warm Air Discharge	Enable, [Disable]	When enabled the indoor airflow will be limited to 80% on a call for heat pump heating. This only applies to heat pump heating with no call for aux heat (An indoor unit with a variable speed blower is required)

5.4.6 Group 6 Airflow Settings

MENU ITEM	OPTIONS [DEFAULT]	DESCRIPTION
VS Blower On Delay - Clg	[No Delay], Enhanced Mode, 7.5 Minutes @ 80%, 4 Minutes @ 80%, 1 Minute @ 50%, 30 Seconds	Select the blower on delay for cooling operation Enhanced Mode is a tiered Blower On Delay for variable speed blowers only (1 minute at 50%, 7.5 minutes at 80%, then 100%)
Non VS Blower On Delay - Clg	[No Delay], 15 Seconds 30 Seconds	Select the blower on delay for cooling operation
VS Blower Off Delay - Clg	[No Delay], 1.5 Minutes @ 100%, 45 Seconds @ 100%, 30 Seconds @ 50%, 1.5 Minutes @ 50%, 3 Minutes @ 50%, 30 Seconds @ 35%	Select the blower off delay for cooling operation
Non VS Blower Off Delay - Clg	[No Delay], 30 Seconds, 60 Seconds, 90 Seconds	Select the blower off delay for cooling operation
VS Blower On Delay - Comp Htg	[No Delay], Enhanced Mode, 7.5 Minutes @ 80%, 4 Minutes @ 80%, 1 Minute @ 50%, 30 Seconds	Select the blower on delay for compressor heating operation Enhanced Mode is a tiered Blower On Delay for variable speed blowers only (1 minute at 50%, 7.5 minutes at 80%, then 100%)
Non VS Blower On Delay - Comp Htg	[No Delay], 15 Seconds, 30 Seconds	Select the blower on delay for compressor heating operation
VS Blower Off Delay - Comp Htg	[No Delay], 1.5 Minutes @ 100%, 45 Seconds @ 100%, 30 Seconds @ 50%, 1.5 Minutes @ 50%, 3 Minutes @ 50%, 30 Seconds @ 35%	Select the blower off delay for compressor heating operation
Non VS Blower Off Delay - Comp Htg	[No Delay], 30 Seconds, 60 Seconds, 90 Seconds	Select the blower off delay for compressor heating operation
Hydronic Heat Blower On Delay	[No Delay], 30 Seconds, 60 Seconds	Select the blower on delay for hydronic heating operation
Hydronic Heat Blower Off Delay	[No Delay], 30 Seconds, 60 Seconds, 90 Seconds	Select the blower off delay for hydronic heating operation
Compressor Low Stage Air Flow% - Comp Clg	35% - 60% [50%]	Select the 1st stage air flow for a two stage/two compressor unit in cooling mode
Compressor Low Stage Air Flow% - Comp Clg	55% - [80%]	Select the 1st stage air flow for a two stage/single compressor unit in cooling mode
Compressor Low Stage Air Flow% - Comp Clg	35% - 60% [50%]	Select the 1st stage air flow for a two stage/two compressor unit in heating mode
Compressor Low Stage Air Flow% - Comp Clg	55% - [80%]	Select the 1st stage air flow for a two stage/single compressor unit in heating mode

5.4.7 Group 7 Lockout Settings

An Outdoor Temperature Sensor must be enabled for Lockout settings to be selectable.

MENU ITEM	OPTIONS [DEFAULT]	DESCRIPTION
Quiet Mode	[Disable], Enable	Enables the installer to limit system operation (heating and cooling mode) to meet local daytime and nighttime sound requirements, if necessary.
Auxiliary Heat Lockout	[Disable], Enable	Enable auxiliary heat lockout (10° minimum separation when enabling auxiliary heat lockout and compressor heat lockout)
Auxiliary Heat Lockout Setting	32°F - 70°F Degrees [45°]	Select an outdoor temperature to prevent auxiliary heat above the selected outdoor temperature
Compressor Lockout	[Disable], Enable	Enable compressor heat lockout (10° minimum separation when enabling auxiliary heat lockout and compressor heat lockout)
Compressor Lockout Setting	5°F - 70°F Degrees [30]	Select an outdoor temperature to prevent compressor heating below the selected outdoor temperature
Defrost Heater Balance Point (W1)	[Disable], Enable	Enable defrost heater balance point for W1, W2 and W3 (only applicable when indoor heat is electric or hydronic)
Defrost Heater Balance Point (W1) Setting	40°F - [55°F]	Select an outdoor temperature to disallow 1st, 2nd and 3rd stage of indoor heat during defrost above this temperature
Defrost Heater Balance Point (W2)	[Disable], Enable	Enable defrost heater balance point for W1 and W2 (only applicable when indoor heat is electric or hydronic)
Defrost Heater Balance Point (W2) Setting	10°F - 50°F [55°F]	Select an outdoor temperature to disallow 2nd and 3rd stage of indoor heat during defrost above this temperature
Defrost Heater Balance Point (W3)	[Disable], Enable	Enable defrost heater balance point for W3 only (only applicable when indoor heat is electric or hydronic)
Defrost Heater Balance Point (W3) Setting	[5°F] - 45°F	Select an outdoor temperature to disallow 3rd stage of indoor heat during defrost above this temperature
Compressor Cooling 1st Stage Lockout	[Disable], Enable	Enable compressor cooling 1st stage lockout
Compressor Cooling 1st Stage Lockout Setting	80°F - [120°F]	Select an outdoor temperature to force the system to 2nd stage compressor cooling
Compressor Heating 1st Stage Lockout	[Disable], Enable	Enable compressor heating 1st stage lockout
Compressor Heating 1st Stage Lockout Setting	0°F - [50°F]	Select an outdoor temperature to force the system to 2nd stage compressor heating
Furnace Heating 1st Stage Lockout	[Disable], Enable	Enable furnace heating 1st stage lockout
Furnace Heating 1st Stage Lockout Setting	0°F - [50°F]	Select an outdoor temperature to force the system to 2nd stage furnace heating

5.5 Service Reminders

Reminders can be enabled to trigger an alert when service is required. The reminder is time-based and can be configured on system run time or calendar days. Reminders can be configured for humidifiers, filters, ventilation systems, UV lights and HVAC system maintenance. The type of reminders available are based on the accessories enabled in the installer settings.

5.6 Dealer Code

When an 850 Control is connected to the Internet, a Dealer Code can be entered to auto-populate the dealer's contact information and logo. The code is the dealer's registered phone number listed on ASDealernet. The Dealer Code is also used to associate this device with a specific dealer on the Dealer Diagnostic Portal.

5.7 Software Updates

To take full advantage of the features and benefits of the 850, the Control should have the latest software revision installed.

When the 850 is connected to a Nexia™ Home Intelligence account, software updates will occur automatically and do not require user intervention.

The software may also be manually updated. This procedure requires a computer with an Internet connection, a USB Flash Drive and the included USB connector. From a computer, go to www.AmericanStandardAir.com. From the Products tab, select Thermostat Controls and click on the 850. Scroll down the page and click on Get Software Updates and follow the on-screen prompts.

6. Basic Operation

6.1 PI Control

The 850 Control uses proprietary control schemes to provide comfort and energy efficiency. The Control senses indoor temperature and determines capacity needed based on the following parameters:

- Mode of operation
- Proportional Error - distance from setpoint
- Integral Error - Time away from setpoint

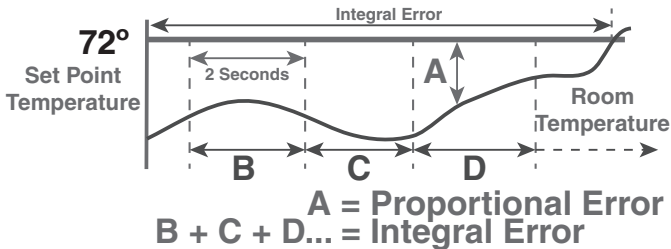

6.2 Load Value - Heating

The 850 Control uses proportional plus integral error to determine the amount of capacity required. The calculated capacity is displayed as load value. Load Value is a numerical representation of the needed capacity to maintain setpoint. The load value range is dependent on the applied system.

0-100	Single Stage Heat Pump Only
0-200	Two State Heat Pump Only
0-200	Single Stage Heat Pump + 1 Stage Electric/Wet Heat
0-300	Single Stage Heat Pump + 2 Stage Electric/Wet Heat
0-400	Single Stage Heat Pump + 3 Stage Electric/Wet Heat
0-300	Two Stage Heat Pump + 1 Stage Electric/Wet Heat
0-400	Two Stage Heat Pump + 2 Stage Electric/Wet Heat
0-500	Two Stage Heat Pump + 3 Stage Electric/Wet Heat
0-100	Single Stage Indoor Heat Only
0-200	Two Stage Indoor Heat Only
0-300	Three Stage Indoor Heat Only
0-175	Single Stage Heat Pump + 1 Stage Gas/Oil Heat
0-275	Single Stage Heat Pump + 2 Stage Gas/Oil Heat
0-375	Single Stage Heat Pump + 2 Stage Gas/Oil Heat
0-275	Two Stage Heat Pump + 1 Stage Gas/Oil Heat
0-375	Two Stage Heat Pump + 2 Stage Gas/Oil Heat
0-475	Two Stage Heat Pump + 3 Stage Gas/Oil Heat

6.3 Load Value - Cooling

0-100 Single Stage Compressor

0-200 Two-Stage Compressor

A Load Value of 50 represents a request of 50% demand for single stage cooling units ("Y") or 50% demand for stage one of multistage cooling units ("Y1").

A Load Value of 150 represents a request of 100% demand for stage one ("Y1") and 50% demand of stage two ("Y2") for multistage cooling units.

6.4 Duty Cycles (non VSPD systems)

Indoor temperature control is achieved by duty cycling the equipment when the load value is less than 100% of the current stage of operation. The duty cycle rate is dependent on the calculated load value.

The duty cycle chart below indicates the number of cycles at 50% load (i.e. LV = 50).

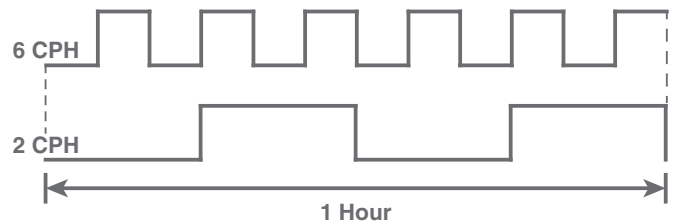

As with all PI-based controls the indoor temperature will fluctuate above and below the user selected setpoint to maintain comfort in the space. Adjusting the factory set CPH (Cycles per Hour) can affect how tight the Control operates around the setpoint. The CPH can be adjusted in the Installer Setup>Equipment Settings (2 – 6 CPH)

- Factory default for compressor operation is 3 CPH
- Factory default for indoor heat is 5 CPH

Effects of changing the cycle rates

Lower CPH results in longer run cycles with less cycling but the indoor temperature may deviate above and below setpoint.

Higher CPH results in tighter indoor temperature control but shorter, more frequent cycles.

6.5 Overshoot Clamp

The 850 Control will enforce an "off cycle" anytime the control overshoots more than 2.5°F. Once the indoor temperature is within 0.75°F of setpoint an "on cycle" is allowed dependent on load value and minimum off times.

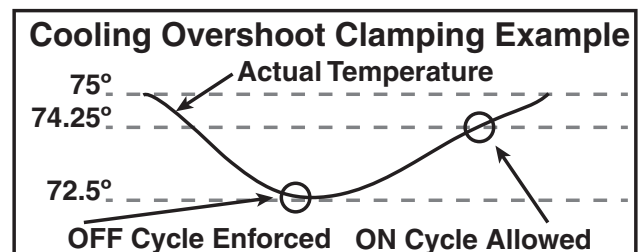

6.6 Stage Thresholds

The threshold to allow operation is a Load Value greater than 5 and operation is always terminated with a Load Value less than 1.

Load Value also determines when additional stages of operation are requested. To prevent rapid cycling between stages, a stage threshold is enforced. The stage threshold is dependent on the applied system.

COMPRESSOR STAGING THRESHOLDS

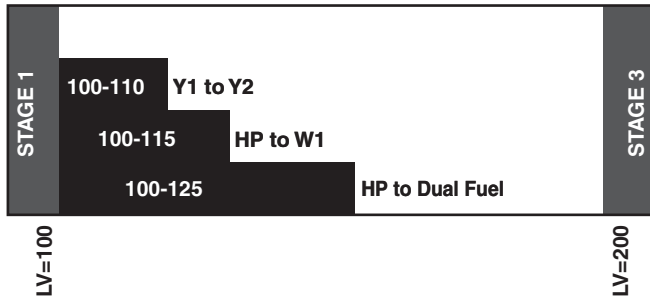

AUX ELECTRIC HEAT - STAGING THRESHOLDS

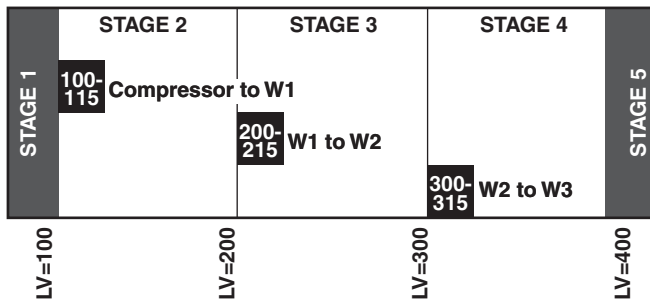

AUX FOSSIL HEAT - STAGING THRESHOLDS

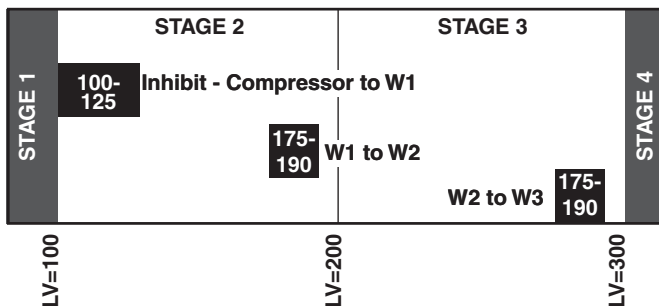

AUX WET HEAT - STAGING THRESHOLDS

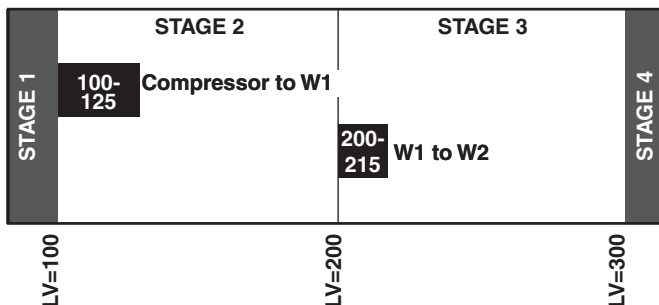

Note: Stage Thresholds do not apply to Variable Speed Outdoor Unit operation.

6.7 Stage Inhibits

When the stage threshold is exceeded, a stage inhibit is applied. The stage inhibit calculates the rate of recovery over a 10-minute period and determines if the next stage is required to meet the current demand. If the rate of recovery is great enough, a new 10-minute inhibit is enabled. The Control will not go to the next stage of operation until it determines that the current stage cannot satisfy the current demand. Stage inhibits only apply between compressor stages and compressor heat to indoor heat. Stage inhibits do not apply to indoor heat stages.

Stage inhibits can be disabled in the 850 Control Installer Setup>Comfort Settings.

Stage Inhibits - Compressor Staging

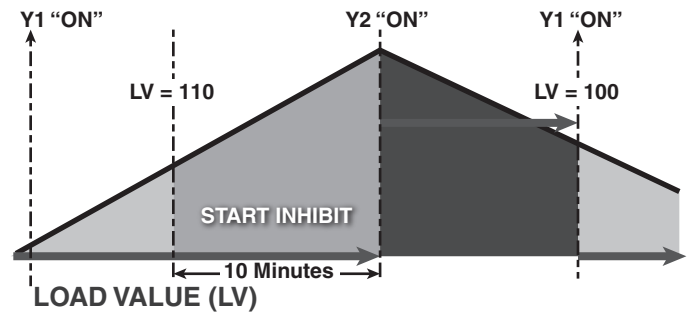

Stage Inhibits - Compressor to Aux Heat

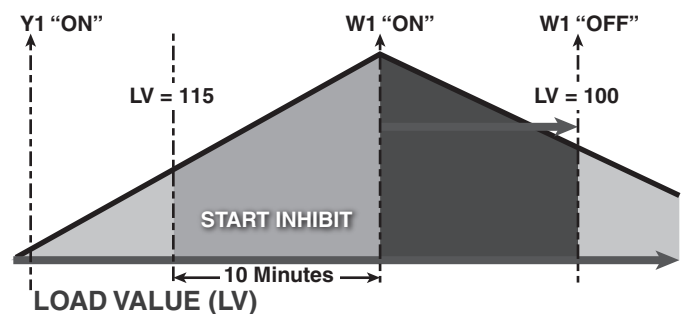

Stage Inhibits - Dual Fuel

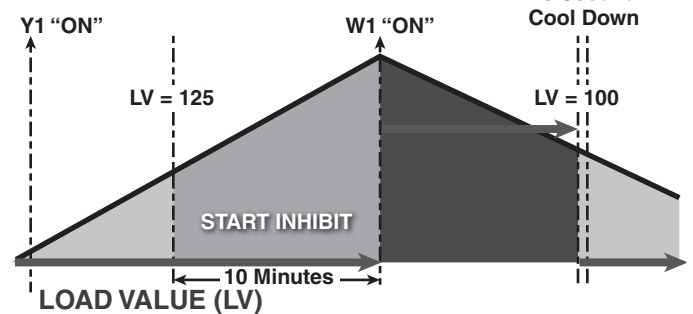

Note: Stage Inhibits do not apply to Variable Speed Outdoor Unit operation.

6.8 System Mode

The 850 has (5) System Modes which can be selected... Heating, Cooling, Off, Emergency Heat and Auto.

- Heating – System will only operate in heating mode
- Cooling – System will only operate in the cooling mode
- Off – System will not operate in heating or cooling mode
- Emergency Heating – System will operate the indoor heat source only (this is only available when the outdoor unit type is a heat pump)
- Auto - The Control will determine which mode of operation based on the following rules:
 - Heating - Indoor temperature is equal or less than heating setpoint
 - Cooling – Indoor temperature is equal to or greater than cooling setpoint or within 1°F of cooling setpoint

There is minimum deadband between heating and cooling setpoints of 3°F

6.9 Quiet Mode

Quiet Mode limits compressor operation (Heating and Cooling Mode) % Demand to meet local sound requirements. There are two effective times that can be adjusted. Day which starts at 9 AM and Night which starts at 10 PM which is required in certain jurisdictions.

The Quiet Mode feature is available on the 850 comfort controls.

Characteristics of Quiet Mode

- When active, the QM symbol will be displayed on the 850 Home Screen.
- When enabled, Quiet Mode limits both heating and cooling modes.
- Quiet mode may be configured to only limit Daytime operation, only limit Nighttime, or limit Daytime and Nighttime to different % demands.
- Night mode affects operation from 10 PM until 9 AM, at which point Day settings for Quiet Mode take over.
- During heating mode, indoor supplemental heat is allowed if the system cannot maintain space conditions while Quiet Mode is active.
- Local code may require auxiliary heat lockout to be configured.

NOTE: Quiet Mode is disabled by default in the homeowner system options. The option to Disable or Enable Quiet Mode is always available to the homeowner. This functionality is accessed from the Home Screen by pressing System Mode> System Options>Enable on the Quiet Mode option. If Quiet Mode is enabled without installer setup, Night operation allows only the minimum % Demand and Day operation allows maximum % Demand. To optimize Quiet Mode performance, the installing dealer must make the changes to the setup found in the Quiet Mode Set-up document available online.

6.10 Fan Mode

The 850 has three Fan Modes:

- Auto – Fan only runs with a call for heating or cooling
- On – Fan runs continuous
- Circ – Fan runs a user selected minimum amount of time each hour

6.11 Air Cleaner Mode

The 850 has three Air Cleaner modes:

- Auto – Air cleaner operates only with a call for fan operation
- Quick – Air cleaner will operate for 3-hours with blower at 100%
- Allergy – Air cleaner will operate for 24-hours with blower at 100%

Note: If a communicating Air Cleaner is installed, the power level will be set to High during Quick and Allergy Clean Modes.

7. Advanced Operation

7.1 Control Response Rate

Allows the user to select a set of higher proportional-integral control constants to increase the responsiveness of the Control. Selecting “Fast” will cause the Control to generate load value at a faster rate. Control Response rate can be adjusted in Installer Setup>Comfort Settings.

7.2 Dehumidification

The 850 utilizes the following methods for dehumidification:

- Air flow reduction (applies only to variable speed blowers) – The 850 can reduce the system air flow by 30% anytime the indoor RH is higher than the cooling RH target. Air flow reduction is disallowed if the indoor temperature is more than 2°F above the cooling setpoint. Dehumidification is factory enabled in the Installer Setup>Comfort Settings.
- All “Fan Off” delays are also defeated when dehumidification is enabled and the indoor RH exceeds the cooling RH target.
- Overcooling (applies to variable speed and non-variable speed blowers) - If overcooling is enabled, the Control will allow a 0.1°F of overcooling for each 1% of RH error. A maximum amount of overcooling can be configured for 1°, 2° or 3°F.

EXAMPLE OF OVERCOOLING WITH MAXIMUM CONFIGURED AT 2°			
TARGET HUMIDITY	ACTUAL HUMIDITY	PERCENT OF RH ERROR	DEGREES OF OVERSHOOT
40%	45%	5%	0.5° Overshoot
40%	55%	15%	1.5° Overshoot
40%	65%	25%	2.0° Overshoot
40%	70%	30%	2.0° Overshoot

When the system is actively overcooling, Dehumidification will be displayed on the 850 home screen. The maximum amount of overcooling is configured in Installer Setup>Comfort settings.

- Smart Continuous Fan (applies to variable speed and non-variable speed blowers) – If enabled, continuous fan operation will be interrupted when indoor RH exceeds desired cooling RH target. A humidity icon will be displayed along with the fan icon to indicate that continuous fan operation has been disabled due to high humidity conditions. Smart Continuous Fan will also interrupt the fan circulate mode when indoor humidity exceeds the desired cooling RH. This feature can be enabled in the Installer Settings>Comfort Settings>Smart Continuous Fan settings.

7.3 Dehumidifier Operation

The 850 has the ability to control a Whole-House Dehumidifier through the normally open dry AUX Contacts on the optional Relay Panel. Control options are:

- Stand Alone Operation – Dehumidifier can operate independent from cooling operation as long as the 850 Control is in Cooling mode or Auto mode and the last call was cooling.

If Stand Alone Operation is selected, the 850 Control allows the user to select whether the indoor fan operates with dehumidifier request.

- With Active Call for Cooling Only – Dehumidifier can only operate during an active call for cooling.

All dehumidifier control options are located in the Installer Setup>Accessories Settings.

7.4 Dual Fuel Operation

The 850 can control a dual fuel system without the need of an external dual fuel kit. An Outdoor Temperature Sensor must be installed and enabled for Restricted Modes to be available. The 850 Control options are:

- Non Restricted Mode – The Control will determine which mode of heat will operate to maintain comfort based on the calculated system load value. With a load value in compressor heating range the heat pump will operate and if the load value climbs to auxiliary heat range, the heat pump will cycle off and the auxiliary heat source will cycle on. Once the load value falls below the auxiliary heat range, the auxiliary heat will cycle off, and the heat pump will cycle back on.
- Restricted Mode (compressor heat only) – Once enabled an outdoor temperature lockout can be set to disable compressor heating operation. When the outdoor temperature falls below the compressor heat lockout the system will operate on auxiliary heat source only. At any temperature above the compressor heat lockout the system will operate the same as non-restricted mode, heat pump or auxiliary heat would be allowed based on system load value. Once the compressor heat is locked out, the outdoor temperature must rise at least 4° above the compressor heat lockout setting before allowing compressor heat again.

Restrict Compressor Heat Only

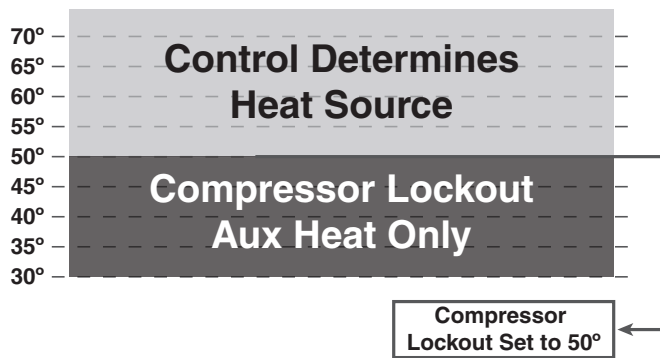

- Restricted Mode (compressor and auxiliary heat) – Once enabled an outdoor temperature lockout can be set to disable compressor heating below and disallow auxiliary heat operation above. When the outdoor temperature is above the auxiliary heat lockout, only compressor heat is allowed. When the outdoor temperature falls below the compressor heat lockout, only auxiliary heat is allowed. When the outdoor temperature is between the compressor heat lockout and auxiliary heat lockout the system will operate the same as non-restricted mode, heat pump or auxiliary heat is allowed based on system load value. There is a 10° minimum dead band between the compressor heat lockout and auxiliary heat lockout. Once the compressor heat or auxiliary heat is locked out, the outdoor temperature must rise or fall at least 4° above or below the lockout setting before allowing compressor or auxiliary heat again.

Restrict Compressor and Aux Heat

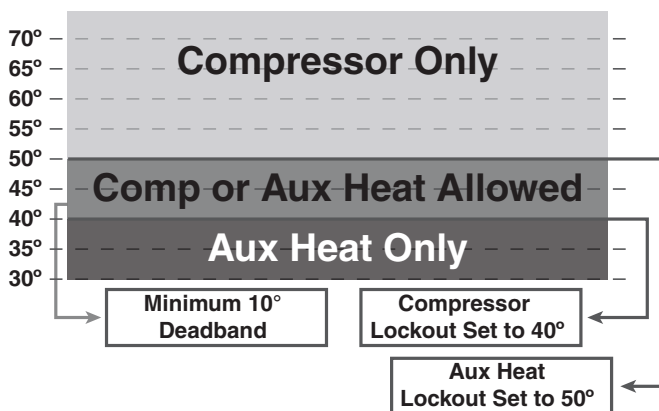

AN OUTDOOR TEMPERATURE SENSOR MUST BE ENABLED FOR LOCKOUT SETTINGS TO BE AVAILABLE. Lockout options are located in the Installer Setup>Lockout Settings.

7.5 Lockouts

The 850 has the following lockouts. **AN OUTDOOR TEMPERATURE SENSOR MUST BE ENABLED FOR LOCKOUT SETTINGS TO BE AVAILABLE.** Lockouts can be enabled in Installer Setup>Lockout Settings.

- Auxiliary Heat Lockout – Once enabled, select an outdoor temperature which disables auxiliary heat anytime the outdoor temperature is above the selected temperature. Compressor heat will be allowed.
- Compressor Lockout - Once enabled, select an outdoor temperature which disables compressor heat anytime the outdoor temperature is below the selected temperature. Indoor heat will be allowed.

NOTE: If enabling Auxiliary Heat Lockout and Compressor Heat Lockout there is a minimum 10° dead band between the two settings.

- Defrost Heater Balance Point (W1) – Once enabled, select an outdoor temperature which disables all electric heat during defrost above the selected temperature.
- Defrost Heater Balance Point (W2) – Once enabled, select an outdoor temperature which disables 2nd and 3rd stages of electric heat during defrost above the selected temperature.
- Defrost Heater Balance Point (W3) – Once enabled, select an outdoor temperature which disables 3rd stage of electric heat during defrost above the selected temperature.
- Compressor Cooling 1st Stage Lockout – Once enabled, select an outdoor temperature which forces 2nd stage cooling operation.
- Compressor Heating 1st Stage Lockout – Once enabled, select an outdoor temperature which forces 2nd stage compressor heating operation.
- Furnace Heating 1st Stage Lockout – Once enabled, select an outdoor temperature which forces 2nd stage furnace heating operation.

Note: If Compressor Lockout is enabled, Compressor Cooling 1st Stage Lockout is disabled.

7.6 Humidifier Operation

The 850 has the ability to control a humidifier. Humidification is only enabled while in heating mode of operation. Control options are:

- RH Control – When the indoor humidity is less than the heating target relative humidity, a request for humidification is sent to the indoor unit.
- Frost Control – The 850 Control references the outdoor temperature and structure integrity to offset the heating target relative humidity. This helps to limit the risk of frost or condensation from forming on interior walls and windows. A scale of 1 to 10 is provided based on the insulation properties and expected leakage of the home (1=Leaky with poor insulation, 10=Very Tight with good insulation). An outdoor temperature sensor must be connected and enabled for frost control to be available.

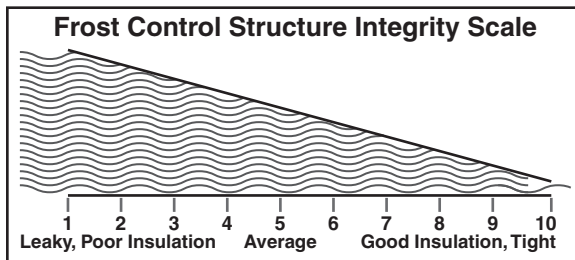

The 850 Control can be setup to allow humidification anytime in heating mode or only when actively heating. The airflow during Humidifier-only is factory set to 100% but can be adjusted between 35%-100% (this requires a variable speed indoor blower). All humidifier control options are located in the Installer Setup>Accessories Settings.

7.7 Recovery

The 850 control utilizes a Stage Inhibit to limit equipment staging. This inhibit can be defeated in the following two manners. See “6.7 Stage Inhibits” on page 14 for more information.

7.7.1 Aggressive Recovery Greater than 2° Setpoint Change

Disables stage inhibits in heating and cooling mode anytime the setpoint is adjusted more than 2°F

7.7.2 Heating Aggressive Recovery By Outdoor Temperature

Disable stage inhibit in heating mode only when the outdoor temperature falls below the selected outdoor temperature.

Note: If Aggressive Recovery is enabled, Heating Aggressive Recovery is disabled.

7.8 Ventilation Operation

The 850 has the ability to control a Ventilation system through the normally open dry AUX Contacts on the optional Relay Panel. The blower is not interlocked on a call for ventilation. The ventilation run time per hour can be adjusted to meet ASHRAE 62.2 standards. A temperature override can be set to prevent ventilation operation when the outdoor temperature exceeds the minimum or maximum outdoor temperature selections. If outdoor temperature overrides are enabled the user can select to accumulate the missed ventilation run time. Options are below:

- Accumulate missed ventilation run time in 4 hour increments and make up when the outdoor temperature is within the min/max settings.
- Accumulate missed ventilation run time in 24 hour increments and make up when the outdoor temperature is within the min/max settings
- Accumulate missed ventilation run time in 4 hour increments and make up at the end of 4 hour period.
- Accumulate missed ventilation run time in 24 hour increments and make up at the end of 24 hour period.

All Ventilation control options are located in the Installer Setup>Accessories Settings.

7.9 Warm Air Discharge

Enabling Warm Air Discharge will reduce the variable speed blower air flow by 20% when in compressor heating operation. Warm Air Discharge only applies to compressor heating and is disabled when hydronic, fossil fuel or electric heat (including supplemental heat) modes are activated. Warm Air Discharge can be enabled in Installer Setup>Comfort Settings.

7.10 Wet Heat (Hydronic) Operation

A hot water coil can be applied to either a variable speed or non-variable speed indoor unit. The hot water coil can be the sole source of heat or used as auxiliary heat when applied with a heat pump. When applied with a heat pump, wet heat is considered auxiliary heat and will operate in-conjunction with heat pump heat. Switching the system mode to emergency heat would disable the heat pump and cycle the wet heat only.

If applied with a variable speed air handler, the blower speed during wet heat only heating will vary based on the system load value. The airflow will range from 35% to 100% depending on the system load value. When applied with a heat pump, the blower speed during heat pump and wet heat operation will be the higher of the two air flows. There are separate blower “On” and “Off” delays for wet heat in the 850 Control.

The 850 Control is designed to operate forced air systems and should not be applied to non-forced air systems (radiant floors, radiators, etc...)

The hydronic heat blower delay options can be accessed by navigating to Installer > Setup > Airflow Settings.

8. Diagnostic Tools

8.1 Test Modes

Access Test Modes by navigating to Service Menu>Test Modes. All test modes will terminate automatically after 60 minutes or can be terminated manually at any time.

8.1.1 Non-Variable Speed

MODE	SETTINGS	DESCRIPTION
Test Blower	50%, 100%	Energize indoor blower at the selected speed
Test Cool	Stage 1 Stage 2	Energize the selected stage of cooling operation. The indoor blower will also operate at the speed required for the selected stage
Test Compressor Heat	Stage 1 Stage 2	Energize the selected stage of compressor heating operation. The indoor blower will also operate at the speed required for the selected stage
Test Indoor Heat	Stage 1 Stage 2 Stage 3	Energize the selected stage of indoor heating operation. The blower operation will be dependent on the indoor heat type: Electric - blower energized during test mode but the blower speed is controlled by the indoor unit Fossil - blower is controlled independently by the indoor unit during test mode Hydronic - blower is energized during test mode
Test Compressor and Indoor Heat	Stage 1 Indoor Heat Stage 2 Indoor Heat Stage 3 Indoor Heat	Energize all stages of compressor heat and selected stage of indoor electric heat/hydronic heat. The blower is energized and runs at the higher of the compressor heat air flow versus indoor heat air flow
More	Test Humidifier, Test Aux Contact	Closes the normally open Humidifier/AUX contacts. The blower is not energized during this test mode

8.1.2 Variable Speed

MODE	SETTINGS	DESCRIPTION
Charging Mode - Cooling	Test	Energizes outdoor unit at the correct compressor speed and associated indoor blower speed to set/verify sytem charge. Use sub-cooling tables in the outdoor unit Service Facts to determine correct charge levels. Outdoor temperature must be within 55F to 120F and indoor temperature must be between 70F to 80F. This is the only approved method for charging/verifying system charge on variable speed systems.
Check Charge Mode - Heating	Test	Energizes outdoor unit at the correct compressor speed and associated indoor blower speed to compare actual performance to typical performance. Use the pressure curves in the outdoor unit Service Facts for comparison. This method is not an approved method for verifying the charge on variable speed systems.
Checkout Mode - Cooling	0-100%	This test mode allows the user to adjust the cooling compressor speed in selected increments from minimum to maximum. The single arrows represent a 1% change and double arrows a 5% change. This test mode allows the user to troubleshoot noise/harmonics which may occur at various compressor speeds.
Checkout Mode - Heating	1 to100%	This test mode allows the user to adjust the heating compressor speed in selected increments from minimum to maximum. The single arrows represent a 1% change and double arrows a 5% change. The user can also initiate a forced defrost cycle from the test mode screen. This test mode allows the user to troubleshoot noise/harmonics which may occur at various compressor speeds.
Pump Down Mode - Cooling	Test	This test mode will pulse the latching switchover valve to cooling position and run at full compressor speed. The outdoor EEV will remain open and the indoor EEV (if installed) will continue to control superheat.
Pump Down Mode - Heating	Test	This test mode will pulse the latching switchover valve to heating position and run at full compressor speed. The outdoor EEV will control superheat and the indoor EEV (if installed) will remain open.

8.2 Save Logs

The 850 Control has the ability to log data on USB Flash Drive. Attach a USB Flash Drive to the included USB connector, plug it into the 850 Control and select Save Logs from the Service Menu.

The amount of data logged will be dependent on the number of days logged and the storage capability of the USB Flash Drive. Access Save Logs by navigating to Service Menu>Save Logs.

8.3 Diagnostics

8.3.1 Alerts

Within the Diagnostic screen are two items related to alerts:

- Current Alerts – Alerts which are currently active
- Alert History – Cleared Alerts (last 30 days)

NOTE: Each alert will have a date/timestamp of when the alert was negated. The Date/Time stamp for Current Alerts is when the alert was asserted. For Alert History the date/timestamp is when the alert was negated.

From both screens the user can select an alert code and get additional information on the alert as well as a list of possible causes, similar to the Interactive Troubleshooting Guide located on ComfortSite/ASDealernet

All alerts are categorized by severity:

- **CRITICAL**
 - Loss of heating/cooling operation
 - Service call is required
 - Alert messages are displayed on the home screen and when closed, a flashing red icon is used to indicate alert condition.
- **MAJOR**
 - Reduced functionality - minimum operation is possible
 - Service call is not immediately required
 - Alert messages are not displayed on the home screen but a yellow icon is used to indicate alert condition.

NOTE: Critical and Major alerts can be displayed on the home screen by pressing the alert icon on the shortcut tool bar (top right of home screen).

- **NORMAL**
 - Functionality may be lost but should recover or the information is for diagnostic purposes / performance monitoring
 - Service call is not required
 - Normal alerts are only displayed in the Diagnostic screen

Diagnostics can be accessed by navigating to Service Menu>Diagnostics.

8.3.2 Summary Table

The 850 Control has a Summary Table which lists all the communicating devices that have been discovered. The screen is made up of four fields:

- Select: Allows user to remove devices that have

a Status of “Offline” from persistent storage. Online devices cannot be removed without being disconnected from the communicating bus.

- Device Information: Lists the device name and model/serial number
- Enabled: Identifies whether the device has been enabled
- Status: Identifies whether the device is currently reporting on the bus (Only “Offline” devices can be removed)

The Enabled and Status field can be used to troubleshooting/informational purposes:

- Enabled + Online: Device has been enabled and is currently reporting on bus
- Enable + Offline: Device has been enabled but is not reporting (Err.126.00 will typically be triggered during this condition).
- Disabled + Online: Device has not been enabled but is reporting (verify device has been configured in the installer settings).
- Disabled + Offline: Device has not been enabled and is currently not reporting.

8.4 History

History is accessed by navigating to Service Menu>History

The History screen allows the technician to view cycle count and run time data for each mode and stage of operation. This data provides a snap-shot into system operations.

	TODAY	LAST 7 DAYS	CURRENT MONTH	LAST MONTH
Y1 COOLING	0 ¹ /0 ²	0 ¹ /0 ²	0 ¹ /0 ²	0 ¹ /0 ²
Y2 COOLING				
Y1 HEATING				
Y2 HEATING				
W1				
W2				
W3				
DEFROST CYCLES				

¹ Indicates cycle count

² Indicates cycle time in minutes

8.5 System Report

The System Report Screen provides technicians with important system operational data in one, concise screen. The data is provided in real-time and updates as the data changes.

8.5.1 Non-Variable Speed Screens

- System Status - mode and stage of operation
- Load Value
- Fan Status
- Indoor Temperature
- Indoor Relative Humidity
- Heating and Cooling Setpoints

- Relative Humidity Setpoints
- Dehumidifier Status
- Outdoor Temperature
- Outdoor Relative Humidity (Nexia™ connection required)

8.5.2 Variable Speed Screens

- Operating State/Stage
- Requested Capacity
- Delivered Compressor Speed %

- Load Value
- Fan Mode/Air Flow %
- Indoor/Outdoor Temperatures
- Heating/Cooling Set Points
- Indoor RH %
- Heating/Cooling RH Set Points

8.6 Restore Factory Defaults

This feature will delete all saved settings, both user and installer, and restore the 850 to its factory default settings. This also includes any Wi-Fi and Z-Wave device settings.

9. Troubleshooting

SYMPTOM	POSSIBLE CAUSES	ACTION
Control displays an alert code on the screen.	A critical or major alert is present.	Navigate to the Diagnostic screen on the 850 Control for a Problem Description and Possible Cause.
Display will not come on	Loss of 24VAC between R & B at the Control.	<ol style="list-style-type: none"> 1) Check wiring between R & B to see if R & D, or B & D have been reversed. 2) Check transformer for 24VAC output. 3) Check for broken or shorted thermostat wire.
Indoor temperature display is incorrect.	<ol style="list-style-type: none"> 1) Control requires one hour to acclimate to environment. 2) Indoor temperature display needs calibration. 3) Heat from touch screen is being trapped within the thermostat body. See section 3.1 for mounting location guidelines. 	<ol style="list-style-type: none"> 1) Allow one hour before proceeding with troubleshooting process. 2) Calibrate temperature sensor from Control menu. 3) Move thermostat away from competing air stream or use a remote temperature sensor
Indoor humidity display is incorrect.	Indoor humidity display needs calibration.	Calibrate humidity sensor from the Control menu.
Room temperature overshoots when the Heat/Cool setting is changed more than 2°.	<ol style="list-style-type: none"> 1) Oversized heating/cooling equipment under current conditions. Control cannot respond fast enough to prevent overshooting. 2) Improper location of Control. 	<ol style="list-style-type: none"> 1) Compare heat load calculation to equipment chosen. 2) Relocate Control (or use remote sensor) if Control is in "dead" spot (poor or no air circulation).
Heating will not come on.	<ol style="list-style-type: none"> 1) System mode is not set to Heat/Auto or setpoint is set too low. 2) Minimum off time delay is being enforced. 3) Heating system may require service. 	<ol style="list-style-type: none"> 1) Set mode to heat and raise the setpoint above the room temperature. 2) Wait for 5 minutes and recheck heating equipment. 3) Check/repair system.
Cooling will not come on.	<ol style="list-style-type: none"> 1) System mode is not set to Cool/Auto or the setpoint is too high. 2) Minimum off time delay is being enforced. 3) Cooling system may require service. 	<ol style="list-style-type: none"> 1) Set mode to cool and lower the setpoint below the room temperature. 2) Wait for 5 minutes and recheck cooling equipment. 3) Check/repair system.
Heating or Cooling is displayed, but no warm or cool air is coming from the registers.	<ol style="list-style-type: none"> 1) There is a fan delay as the heating or cooling equipment turns on. 2) Equipment is not working properly. 	<ol style="list-style-type: none"> 1) Wait a minute for blower delays and recheck registers. 2) Check/repair system.
Fan runs all the time	<ol style="list-style-type: none"> 1) Fan mode is set to On, Circulate or Clean mode 2) There is a failure in the indoor unit 	<ol style="list-style-type: none"> 1) Check Control settings to see if fan is set to On, Circulate or Clean mode. 2) Check indoor unit for failures (such as tripped heating limit).
"+" symbol appears on Home Screen beneath Indoor Temperature readout	Both compressor heat and indoor heat are being called simultaneously	No action required, symbol is for informational purposes only
Fan is set to ON but not running.	<ol style="list-style-type: none"> 1) Humidity Control is engaged. 2) Blower motor is not functioning. 	<ol style="list-style-type: none"> 1) If indoor humidity is higher than desired setpoint, the blower will cycle off with the equipment. A humidity icon will be displayed on the Fan Mode button when the blower operation is being inhibited due too high humidity. 2) Check/repair system.
Cooling or Heating cycles too fast or too slow (narrow or wide temperature swings).	<ol style="list-style-type: none"> 1) Check the location of the Control for drafts. 2) Cycles per hour or aggressive recovery is improperly set. 	<ol style="list-style-type: none"> 1) Seal air leaks behind Control. Relocate Control or apply remote indoor temperature sensor. 2) Adjust cycle rates and aggressive recovery features in the advanced installer set up.
Heat pump is not turning on; only furnace or electric heat strips are running.	<ol style="list-style-type: none"> 1) Outdoor temperature is below compressor lockout temperature setting. 2) Compressor heating lockout is enabled and outdoor temp sensor is out of calibration or failed. 3) The outdoor unit is not reporting (Err.126.00) 	<ol style="list-style-type: none"> 1) Adjust the compressor lockout temperature setting if desired. 2) Check/repair outdoor sensor or wiring. 3) Check communication status of outdoor unit.
Cannot change system mode to desired setting.	Equipment is not configured properly.	Check the standard installer set up screen to ensure equipment is properly configured.
Screen does not respond properly to a button press	<ol style="list-style-type: none"> 1) Screen is out of calibration. 2) Internal Control fault 	<ol style="list-style-type: none"> 1) Remove Control from sub base and reset. Follow the calibration instructions when the Control reboots. 2) Remove Control from sub base and reset.

10. Notices

10.1 FCC Notice

INFORMATION TO USER

This device complies with Part 15 of the FCC Rules. Operation is subject to the following two conditions: (1) This device may not cause harmful interference and (2) This device must accept any interference received, including interference that may cause undesired operation. The antenna(s) used for this transmitter must be installed to provide a separation distance of at least 20 cm from all persons and must not be collocated or operating in conjunction with any other antenna or transmitter.

This equipment has been tested and found to comply with the limits for Class B Digital Device, pursuant to Part 15 of the FCC Rules. These limits are designed to provide reasonable protection against harmful interference in a residential installation. This equipment generates and can radiate radio frequency energy and, if not installed and used in accordance with the instructions, may cause harmful interference to radio communications. However, there is no guarantee that interference will not occur in a particular installation. If this equipment does cause harmful interference to radio or television reception, which can be determined by turning the equipment off and on, the user is encouraged to try to correct the interference by one or more of the following measures.

- Reorient or relocate the receiving antenna
- Increase the separation between the equipment and receiver
- Connect the equipment into an outlet on a circuit different from that to which the receiver is connected
- Consult the dealer or an experienced radio/TV technician for help

Any changes or modifications not expressly approved by the party responsible for compliance could void the user's authority to operate the equipment.

10.2 IC Notice

This device complies with Industry Canada license-exempt RSS standard(s). Operation is subject to the following two conditions: (1) this device may not cause interference, and (2) this device must accept any interference, including interference that may cause undesired operation of the device.

Le présent appareil est conforme aux CNR d'Industrie Canada applicables aux appareils radio exempts de licence. L'exploitation est autorisée aux deux conditions suivantes : (1) l'appareil ne doit pas produire de brouillage, et (2) l'utilisateur de l'appareil doit accepter tout brouillage radioélectrique subi, même si le brouillage est susceptible d'en compromettre le fonctionnement.



About American Standard Heating and Air Conditioning
American Standard has been creating comfortable and affordable living environments for more than a century. For more information, please visit www.americanstandardair.com.

The manufacturer has a policy of continuous data improvement and it reserves the right to change design and specifications without notice. We are committed to using environmentally conscious print practices.

11-HD14D1-9A-EN 07 Aug 2020
Supersedes 11-HD14D1-9-EN (September 2018)

© 2020 American Standard Heating and Air Conditioning