

Product Data

4DCY4024 through 4DCY4060

Packaged Convertible Dual Fuel

14 SEER

2 – 5 Ton, 60 – 120 MBTU

R-410A

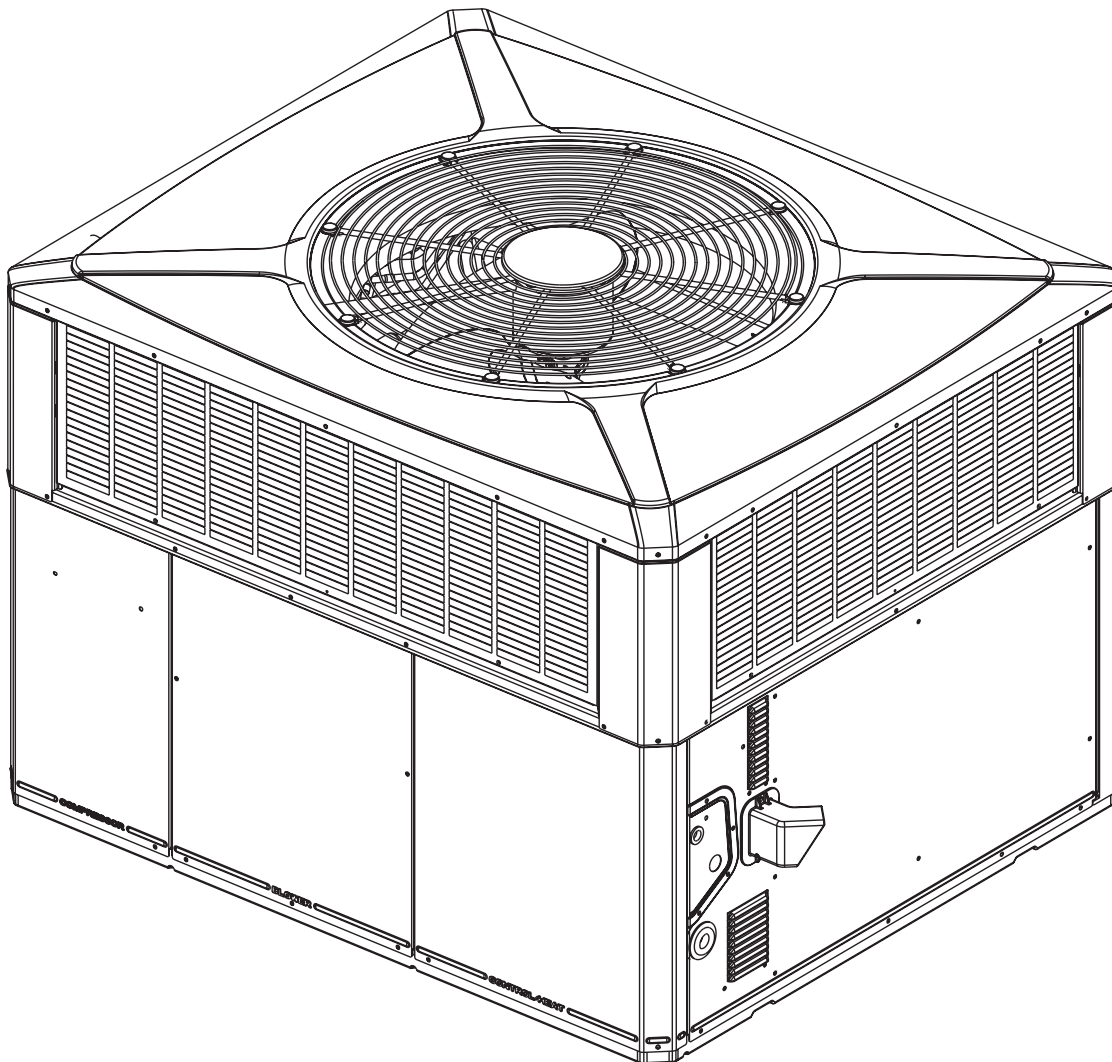

Packaged Convertible Dual Fuel System

American Standard Heating & Air Conditioning offers a complete family of dual fuel heating and cooling systems, designed to keep you comfortable all year long, regardless of the weather, while keeping your operating costs as low as possible. The heat pump operates efficiently as both an air conditioner and a heater. In the summer, the heat pump cools your home just like any other air conditioner by pulling the heat from the inside and releasing it outdoors. In the winter, it captures the heat that is always present in the outdoor air and transfers it indoors. The gas furnace provides additional heating capacity for cooler weather.

Introducing the new American Standard Heating & Air Conditioning Packaged Convertible Dual Fuel System.

Single Packaged Convertible Dual Fuel Systems are easy and versatile to install. Because cooling and heating functions are all contained in a single cabinet, an American Standard Heating & Air Conditioning packaged dual fuel system is easy to install and service. It can be flush mounted beside your home at ground level or placed on the roof for horizontal or downflow installation. When connected to a *CONT402, 802, or 803 comfort control, and air distribution ducts, you have a highly efficient, total home comfort system.

Single Packaged Dual Fuel Systems are unmatched in quality and reliability. All major components on these products, including the compressor, have been designed and manufactured for maximum service. Every Duration™ compressor is designed and manufactured to exacting specifications. Each design is life tested in extreme environments to ensure reliable and long lasting operation in normal applications. Each compressor has internal motor protection for added reliability.

Contents

| | |
|-----------------------------------|-----------|
| Optional Equipment Listing | 4 |
| <hr/> | |
| General Data | 5 |
| <hr/> | |
| Indoor Blower Performance | 9 |
| <hr/> | |
| Typical Wiring | 12 |
| <hr/> | |
| Optional Equipment | 23 |
| <hr/> | |
| Dimensional Data | 28 |
| <hr/> | |
| Mechanical Specifications | 34 |
| <hr/> | |

Optional Equipment Listing

OPTIONAL EQUIPMENT FOR 4DCY4 PACKAGED UNITS (check mark [✓] indicates accessories included)

| | | |
|---|-------|----------------|
| Hinged Filter Access Door (4DCY4024-036) ③ | | BAYACCDOR1A[] |
| Hinged Filter Access Door (4DCY4042-060) ③ | | BAYACCDOR2A[] |
| Roof Curb Full Perimeter (4DCY4024-036) ③ | | BAYCURB050A[] |
| Roof Curb Full Perimeter (4DCY4042-060) ③ | | BAYCURB051A[] |
| Roof Curb Utility Extension Kit (BAYCURB050A) | | BAYUTIL101B[] |
| Roof Curb Utility Extension Kit (BAYCURB051A) | | BAYUTIL102B[] |
| 0-25% Manual Fresh Air Damper (4DCY4024-36) ① | | BAYOSAH001A[] |
| 0-25% Manual Fresh Air Damper (4DCY4042-060) ① | | BAYOSAH002A[] |
| Motorized Fresh Air Damper (4DCY4024-36) ① | | BAYDMPR101A[] |
| Motorized Fresh Air Damper (4DCY4042-060) ① | | BAYDMPR102A[] |
| 16" Round Duct Adapter (2 per box) (4DCY4024-36) ⑥ | | BAYSQRD001A[] |
| 18" Round Duct Adapter (2 per box) (4DCY4042-060) ⑥ | | BAYSQRD002A[] |
| 0-100% Mod Economizer w/Baro. Relief (4DCY4024-36) ①②④ | | BAYECON101B[] |
| 0-100% Mod. Economizer w/Baro. Relief (4DCY4042-060) ①②④ | | BAYECON102B[] |
| 0-100% Horizontal Economizer (4DCY4024-36) ①② | | BAYECON200A[] |
| 0-100% Horizontal Economizer (4DCY4042-060) ①② | | BAYECON201A[] |
| Economizer Relay Kit (required for Heat Pump applications) | | BAYRLAY004A[] |
| Enthalpy Control for Economizer (solid state) | | BAYENTH001A[] |
| Remote Potentiometer (All-BAYECON***A) | | BAYSTAT023[] |
| 1"-2" Filter Frame (4DCY4024-36) (20 x 25 filter not included) ① | | BAYFLTR101B[] |
| 1"-2" Filter Frame (4DCY4042-60) (20 x 20 & 20 x18 filter not included) ① | | BAYFLTR201B[] |
| Head Pressure Control (Low Ambient Cool) (208/240v) Kit ⑤ | | BAYLOAM105A[] |
| Quick Start Kit (4DCY4-‡1) | | BAYQSKT300A[] |
| Crankcase Heater Recip (4DCY4024, 30)(230v) ⑤ | | BAYCCHT101A[] |
| Crankcase Heater Scroll(4DCY4042, 48, 60)(230v) ⑤ | | BAYCCHT102A[] |
| Crankcase Heater Scroll(4DCY4036)(230v) ⑤ | | BAYCCHT103A[] |
| Adapter Curb 4DCY4024-36 to BAYCURB030,38 | | BAYADAP050A[] |
| Adapter Curb 4DCY4024-36 to BAYCURB033 | | BAYADAP051A[] |
| Adapter Curb 4DCY4042-60 to BAYCURB030,38 | | BAYADAP052A[] |
| Adapter Curb 4DCY4042-60 to BAYCURB033 | | BAYADAP053A[] |
| Adapter Curb 4DCY4042-60 to BAYCURB034 | | BAYADAP054A[] |
| 12" Duct Shroud Covers Horizontal *DCY4024-60 ⑦ | | BAYCOVR112A[] |
| 18" Duct Shroud Covers Horizontal *DCY4042-60 ⑦ | | BAYCOVR118A[] |
| Extreme Condition Mounting Kit - All BAYCURB & BAYADAP | | BAYEXMK001A[] |
| Extreme Condition Mounting Kit - All BAYUTIL | | BAYEXMK002B[] |
| Extreme Condition Mounting Kit - All Slab Mounts | | BAYEXMK003A[] |
| Lifting Lug Kit | | BAYLIFT002B[] |
| LP Conversion Kit (All 40K, 120K Models) | | BAYLPKT100A[] |
| LP Conversion Kit (All 64K, 96K Models) | | BAYLPKT101A[] |
| LP Conversion Kit (All 75K Models) | | BAYLPKT102A[] |

- NOTES: ① Must use internal filter frame when economizer or fresh air kit is used.
 ② Dry bulb control standard with economizer.
 ③ Ships knocked down.
 ④ Downflow only.
 ⑤ Low Ambient cooling requires crankcase heater (BAYCCHT---A).
 ⑥ It is the responsibility of the installing dealer to properly size the ductwork for each specific application.
 ⑦ BAYCOVR112,118A will not cover BAYSQRD002A applications.
 ⑧ BAYACCDOR1A requires BAYFLTR101B & BAYACCDOR2A requires BAYFLTR201B. They are not backward compatible to BAYFLTR101/201A.
 ‡ = A or B

General Data

| MODEL | 4DCY4024C1060A | 4DCY4030C1070A | 4DCY4030D1070A |
|---------------------------------------|---------------------------|---------------------------|---------------------------|
| RATED Volts/PH/Hz | 208-230/1/60 | 208-230/1/60 | 208-230/1/60 |
| Performance Cooling BTUH ① | 23600 | 30000 | 30000 |
| Indoor Airflow (CFM) | 760 | 880 | 985 |
| Power Input (KW) | 2.162 | 2.15 | 2.15 |
| EER/SEER(BTU/Watt-Hr.)⑤ | 12 / 14.0 | 12.0 / 14.25 | 12.0 / 14.25 |
| Sound Power Rating [dB(A)]⑦ | 68 | 71 | 70 |
| HP Heating Performance | | | |
| (High Temp.)BTUH / COP | 22400 / 3.7 | 28000 / 3.9 | 28000 / 3.9 |
| Power Input (KW) | 1.77 | 2.15 | 2.15 |
| (Low Temp.) BTUH / COP | 11600 / 2.38 | 15400 / 2.48 | 15400 / 2.48 |
| Power Input (KW) | 1.24 | 1.81 | 1.81 |
| HSPF (BTU / Watt-Hr.) | 8.0 | 8.0 | 8.0 |
| Gas Heating Performance ② | | | |
| (High) Input BTUH | 60000 | 70000 | 70000 |
| Capacity BTUH | 48600 | 56700 | 56700 |
| Temp. Rise — Min/Max (°F) | 40 / 70 | 30 / 60 | 30 / 60 |
| (Low) Input BTUH | 48000 | 56000 | 56000 |
| Capacity BTUH | 38880 | 45360 | 45360 |
| AFUE | 81 | 81 | 81 |
| Type of Gas ③ | NATURAL/LP | NATURAL/LP | NATURAL/LP |
| Gas Pipe Size (in.) | 1/2 | 1/2 | 1/2 |
| POWER CONN.—V/PH/HZ | 208-230/1/60 | 208-230/1/60 | 208-230/1/60 |
| Min. Brch. Cir. Ampacity④ | 16.1 | 19.1 | 22.8 |
| Fuse Size — Max. (amps) | 25 | 30 | 35 |
| Fuse Size — Recmd. (amps) | 25 | 30 | 35 |
| COMPRESSOR | RECIPROCATING | RECIPROCATING | SCROLL |
| Volts/Ph/Hz | 208-230/1/60 | 200-230/1/60 | 200-230/1/60 |
| R.L. Amps — L.R. Amps | 8.3 / 57.8 | 11.1 / 63 | 14.1 / 73 |
| OUTDOOR COIL — TYPE | SPINE-FIN | SPINE-FIN | SPINE-FIN |
| Rows/F.P.I. | 2 / 24 | 2 / 24 | 2 / 24 |
| Face Area (sq.ft.) | 13.32 | 13.32 | 13.32 |
| Tube Size (in.) | 3/8 | 3/8 | 3/8 |
| Refrigerant Control | EXPANSION VALVE | EXPANSION VALVE | EXPANSION VALVE |
| INDOOR COIL — TYPE | PLATE FIN | PLATE FIN | PLATE FIN |
| Rows/F.P.I. | 3 / 15 | 4 / 15 | 4 / 15 |
| Face Area (sq.ft.) | 3.54 | 3.54 | 3.54 |
| Tube Size (in.) | 3/8 | 3/8 | 3/8 |
| Refrigerant Control | EXPANSION VALVE | EXPANSION VALVE | EXPANSION VALVE |
| Drain Conn. Size (in.) | 3/4 FEMALE NPT | 3/4 FEMALE NPT | 3/4 FEMALE NPT |
| OUTDOOR FAN — TYPE | PROPELLER | PROPELLER | PROPELLER |
| Dia. (in.) | 23.4 | 23.4 | 23.4 |
| Drive/No. Speeds | DIRECT / 1 | DIRECT / 1 | DIRECT / 1 |
| CFM @ 0.0 in. w.g. ⑦ | 2590 | 3250 | 3250 |
| Motor — HP/R.P.M. | 1/12 / 810 | 1/6 / 830 | 1/6 / 830 |
| Volts/Ph/Hz | 208-230/1/60 | 208-230/1/60 | 208-230/1/60 |
| F.L. Amps/L.R. Amps | 0.54 / 0.95 | 1.0 / 1.7 | 1.0 / 1.7 |
| INDOOR FAN — TYPE | CENTRIFUGAL | CENTRIFUGAL | CENTRIFUGAL |
| Dia x Width (in.) | 10 X 10 | 10 X 10 | 10 X 10 |
| Drive/No. Speeds | DIRECT / VARIABLE | DIRECT / VARIABLE | DIRECT / VARIABLE |
| CFM @ 0.0 in. w.g.⑧ | SEE FAN PERFORMANCE TABLE | SEE FAN PERFORMANCE TABLE | SEE FAN PERFORMANCE TABLE |
| Motor — HP/R.P.M. | 1/2 / VARIABLE | 1/2 / VARIABLE | 1/2 / VARIABLE |
| Volts/Ph/Hz | 200-230/1/60 | 208-230/1/60 | 208-230/1/60 |
| F.L. Amps/L.R. Amps | 4.3 / 4.3 | 4.3 / 4.3 | 4.3 / 4.3 |
| COMBUSTION FAN — TYPE | CENTRIFUGAL | CENTRIFUGAL | CENTRIFUGAL |
| Drive/No. Speeds | DIRECT / 2 | DIRECT / 2 | DIRECT / 2 |
| Motor — HP/R.P.M. (High/Low) | 1/20 / 3350/2600 | 1/20 / 3350/2600 | 1/20 / 3350/2600 |
| Volts/Ph/Hz | 208-230/1/60 | 208-230/1/60 | 208-230/1/60 |
| FLA | 0.34 | 0.34 | 0.34 |
| FILTER / FURNISHED | NO | NO | NO |
| Type Recommended | THROWAWAY | THROWAWAY | THROWAWAY |
| Recmd. Face Area (sq. ft.)⑥ | 4 | 4 | 4 |
| REFRIGERANT / Charge (lbs.) | R410A / 6.5 | R410A / 6.56 | R410A / 6.56 |
| DIMENSIONS | H X W X L | H X W X L | H X W X L |
| Crated (in.) | 45.86 / 44.5 / 52.03 | 45.86 / 44.5 / 52.03 | 48 / 45 / 52 |
| WEIGHT / Shipping / Net (lbs.) | 481 / 385 | 481 / 385 | 481 / 385 |

① Certified in accordance with the Unitary Air-Conditioner Equipment certification program, which is based on AHRI Standard 210/240.

② All models are U L Listed. Ratings shown are for elevations up to 2000 ft. For higher elevations reduce ratings at a rate of 4% per 1000 ft. elevation.

③ Convertible to LPG.

④ This value is approximate. For more precise value, see Unit Nameplate.

⑤ Based on U.S. Government Standard Tests.

⑥ Filters must be installed in return air stream. Square footages listed are based on 300 f.p.m. face velocity. If permanent filters are used size per manufacturer's recommendation with a clean resistance of 0.05" W.C.

⑦ Sound Power values are not adjusted for AHRI 270-95 tonal corrections.

⑧ Standard Air — Dry Coil — Outdoor.

General Data

| MODEL | 4DCY4036C1070A | 4DCY4036B3075A | 4DCY4042C1090A |
|--|---------------------------|---------------------------|---------------------------|
| RATED Volts/PH/Hz | 208-230/1/60 | 208-230/3/60 | 208-230/1/60 |
| Performance Cooling BTUH ^① | 37000 | 36000 | 42000 |
| Indoor Airflow (CFM) | 1150 | 1185 | 1380 |
| Power Input (KW) | 3.11 | 3.28 | 3.50 |
| EER/SEER(BTU/Watt-Hr.) ^⑤ | 12.0 / 14.0 | 11.4 / 14.0 | 12.0 / 14.0 |
| Sound Power Rating [dB(A)] ^⑦ | 69 | 69 | 74 |
| HP Heating Performance | | | |
| (High Temp.)BTUH / COP | 33200 / 3.6 | 32400 / 3.5 | 38000 / 3.45 |
| Power Input (KW) | 2.7 | 2.7 | 3.23 |
| (Low Temp.) BTUH / COP | 22400 / 2.4 | 20600 / 2.36 | 23400 / 2.32 |
| Power Input (KW) | 2.5 | 2.6 | 2.96 |
| HSPF (BTU / Watt-Hr.) | 8.0 | 8.0 | 8.0 |
| Gas Heating Performance ^② | | | |
| (High) Input BTUH | 70000 | 75000 | 90000 |
| Capacity BTUH | 56700 | 60500 | 72900 |
| Temp. Rise — Min/Max (°F) | 30 / 60 | 30 / 60 | 30 / 60 |
| (Low) Input BTUH | 56000 | 56250 | 72000 |
| Capacity BTUH | 45360 | 48400 | 58320 |
| AFUE | 81 | 80.0 | 81 |
| Type of Gas ^③ | NATURAL/LP | NATURAL | NATURAL/LP |
| Gas Pipe Size (in.) | 1/2 | 1/2 | 1/2 |
| POWER CONN.—V/PH/Hz | 208-230/1/60 | 208-230/3/60 | 208-230/1/60 |
| Min. Brch. Cir. Ampacity ^④ | 26.2 | 18.5 | 30.8 |
| Fuse Size — Max. (amps) | 40 | 25 | 45 |
| Fuse Size — Recmd. (amps) | 40 | 25 | 45 |
| COMPRESSOR | SCROLL | SCROLL | SCROLL |
| Volts/Ph/Hz | 208-230/1/60 | 208-230/3/60 | 208-230/1/60 |
| R.L. Amps — L.R. Amps | 16.7 / 79 | 10.4 / 73 | 17.9 / 112 |
| OUTDOOR COIL — TYPE | SPINE-FIN | SPINE-FIN | SPINE-FIN |
| Rows/F.P.I. | 2 / 24 | 2 / 24 | 2 / 24 |
| Face Area (sq.ft.) | 15.49 | 15.49 | 18.01 |
| Tube Size (in.) | 3/8 | 3/8 | 3/8 |
| Refrigerant Control | EXPANSION VALVE | EXPANSION VALVE | EXPANSION VALVE |
| INDOOR COIL — TYPE | PLATE FIN | PLATE FIN | PLATE FIN |
| Rows/F.P.I. | 4 / 15 | 4 / 15 | 3 / 15 |
| Face Area (sq.ft.) | 3.54 | 3.54 | 5 |
| Tube Size (in.) | 3/8 | 3/8 | 3/8 |
| Refrigerant Control | EXPANSION VALVE | EXPANSION VALVE | EXPANSION VALVE |
| Drain Conn. Size (in.) | 3/4 FEMALE NPT | 3/4 FEMALE NPT | 3/4 FEMALE NPT |
| OUTDOOR FAN — TYPE | PROPELLER | PROPELLER | PROPELLER |
| Dia. (in.) | 23.4 | 23.4 | 28.2 |
| Drive/No. Speeds | DIRECT / 1 | DIRECT / 1 | DIRECT / 1 |
| CFM @ 0.0 in. w.g. ^⑦ | 3310 | 3270 | 4440 |
| Motor — HP/R.P.M. | 1/5 / 830 | 1/5 / 830 | 1/4 / 825 |
| Volts/Ph/Hz | 208-230/1/60 | 208-230/1/60 | 208-230/1/60 |
| F.L. Amps/L.R. Amps | 1.1 / 1.9 | 1.1 / 1.9 | 1.5 / 3.4 |
| INDOOR FAN — TYPE | CENTRIFUGAL | CENTRIFUGAL | CENTRIFUGAL |
| Dia x Width (in.) | 10 X 10 | 10 X 10 | 11 X 10 |
| Drive/No. Speeds | DIRECT / VARIABLE | DIRECT / VARIABLE | DIRECT / VARIABLE |
| CFM @ 0.0 in. w.g. ^⑤ | SEE FAN PERFORMANCE TABLE | SEE FAN PERFORMANCE TABLE | SEE FAN PERFORMANCE TABLE |
| Motor — HP/R.P.M. | 1/2 / VARIABLE | 1/2 / VARIABLE | 3/4 / VARIABLE |
| Volts/Ph/Hz | 200-230/1/60 | 200-230/1/60 | 208-230/1/60 |
| F.L. Amps/L.R. Amps | 4.3 / 4.3 | 4.3 / 4.3 | 6.8 / 6.8 |
| COMBUSTION FAN — TYPE | CENTRIFUGAL | CENTRIFUGAL | CENTRIFUGAL |
| Drive/No. Speeds | DIRECT / 2 | DIRECT / 2 | DIRECT / 2 |
| Motor — HP/R.P.M. (High/Low) | 1/20 / 3350/2600 | 1/45 / 2800/1500 | 1/20 / 3350/2600 |
| Volts/Ph/Hz | 208-230/1/60 | 208-230/1/60 | 208-230/1/60 |
| FLA | 0.34 | 0.34 | 0.34 |
| FILTER / FURNISHED | NO | NO | NO |
| Type Recommended | THROWAWAY | THROWAWAY | THROWAWAY |
| Recmd. Face Area (sq. ft.) ^⑥ | 4 | 4 | 5.3 |
| REFRIGERANT / Charge (lbs.) | R410A / 7.5 | R410A / 7.4 | R410A / 8.2 |
| DIMENSIONS | H X W X L | H X W X L | H X W X L |
| Crated (in.) | 47.86 / 44.5 / 52.03 | 47.86 / 44.5 / 52.03 | 47.86 / 47.4 / 61.75 |
| WEIGHT / Shipping / Net (lbs.) | 488 / 392 | 488 / 392 | 653 / 525 |

① Certified in accordance with the Unitary Air-Conditioner Equipment certification program, which is based on AHRI Standard 210/240.

② All models are U L Listed. Ratings shown are for elevations up to 2000 ft. For higher elevations reduce ratings at a rate of 4% per 1000 ft. elevation.

③ Convertible to LPG.

④ This value is approximate. For more precise value, see Unit Nameplate.

⑤ Based on U.S. Government Standard Tests.

⑥ Filters must be installed in return air stream. Square footages listed are based on 300 f.p.m. face velocity. If permanent filters are used size per manufacturer's recommendation with a clean resistance of 0.05" W.C.

⑦ Sound Power values are not adjusted for AHRI 270-95 tonal corrections.

⑧ Standard Air — Dry Coil — Outdoor.

General Data

| | | |
|--|---------------------------|---------------------------|
| MODEL | 4DCY4048C1090A | 4DCY4048A3096C |
| RATED Volts/PH/Hz | 208-230/1/60 | 208-230/3/60 |
| Performance Cooling BTUH ^① | 47500 | 43000 |
| Indoor Airflow (CFM) | 1470 | 1470 |
| Power Input (KW) | 3.96 | 4.03 |
| EER/SEER(BTU/Watt-Hr.) ^⑤ | 12.0 / 14.0 | 10.85 / 14.0 |
| Sound Power Rating [dB(A)] ^⑦ | 73 | 73 |
| HP Heating Performance | | |
| (High Temp.)BTUH / COP | 45000 / 3.5 | 42500 / 3.5 |
| Power Input (KW) | 3.77 | 3.56 |
| (Low Temp.) BTUH / COP | 28400 / 2.42 | 26800 / 2.3 |
| Power Input (KW) | 3.44 | 3.44 |
| HSPF (BTU / Watt-Hr.) | 8.0 | 8.0 |
| Gas Heating Performance ^② | | |
| (High) Input BTUH | 90000 | 96000 |
| Capacity BTUH | 72900 | 77500 |
| Temp. Rise — Min/Max (°F) | 30 / 60 | 30 / 60 |
| (Low) Input BTUH | 72000 | 72000 |
| Capacity BTUH | 58320 | 62000 |
| AFUE | 81 | 80 |
| Type of Gas ^③ | NATURAL/LP | NATURAL |
| Gas Pipe Size (in.) | 1/2 | 1/2 |
| POWER CONN.—V/PH/HZ | | |
| Min. Brch. Cir. Ampacity ^④ | 208-230/1/60 | 208-230/3/60 |
| Fuse Size — Max. (amps) | 33.9 | 25.3 |
| Fuse Size — Recmd. (amps) | 50 | 35 |
| | 50 | 35 |
| COMPRESSOR | | |
| | SCROLL | SCROLL |
| Volts/Ph/Hz | 208-230/1/60 | 208-230/3/60 |
| R.L. Amps — L.R. Amps | 20.5 / 109 | 13.7 / 83.1 |
| OUTDOOR COIL — TYPE | | |
| | SPINE-FIN | SPINE-FIN |
| Rows/F.P.I. | 2 / 24 | 2 / 24 |
| Face Area (sq.ft.) | 18.01 | 18.01 |
| Tube Size (in.) | 3/8 | 3/8 |
| Refrigerant Control | EXPANSION VALVE | EXPANSION VALVE |
| INDOOR COIL — TYPE | | |
| | PLATE FIN | PLATE FIN |
| Rows/F.P.I. | 3 / 15 | 3 / 15 |
| Face Area (sq.ft.) | 5.0 | 5.0 |
| Tube Size (in.) | 3/8 | 3/8 |
| Refrigerant Control | EXPANSION VALVE | EXPANSION VALVE |
| Drain Conn. Size (in.) | 3/4 FEMALE NPT | 3/4 FEMALE NPT |
| OUTDOOR FAN — TYPE | | |
| | PROPELLER | PROPELLER |
| Dia. (in.) | 28.2 | 28.2 |
| Drive/No. Speeds | DIRECT / 1 | DIRECT / 1 |
| CFM @ 0.0 in. w.g. ^⑦ | 4450 | 4450 |
| Motor — HP/R.P.M. | 1/4 / 825 | 1/4 / 825 |
| Volts/Ph/Hz | 208-230/1/60 | 208-230/1/60 |
| F.L. Amps/L.R. Amps | 1.4 / 3.5 | 1.4 / 3.5 |
| INDOOR FAN — TYPE | | |
| | CENTRIFUGAL | CENTRIFUGAL |
| Dia x Width (in.) | 11 X 10 | 11 X 10 |
| Drive/No. Speeds | DIRECT / VARIABLE | DIRECT / VARIABLE |
| CFM @ 0.0 in. w.g. ^⑤ | SEE FAN PERFORMANCE TABLE | SEE FAN PERFORMANCE TABLE |
| Motor — HP/R.P.M. | 3/4 / VARIABLE | 3/4 / VARIABLE |
| Volts/Ph/Hz | 200-230/1/60 | 200-230/1/60 |
| F.L. Amps/L.R. Amps | 6.8 / 6.8 | 6.8 / 6.8 |
| COMBUSTION FAN — TYPE | | |
| | CENTRIFUGAL | CENTRIFUGAL |
| Drive/No. Speeds | DIRECT / 2 | DIRECT / 2 |
| Motor — HP/R.P.M. (High/Low) | 1/20 / 3350/2600 | 1/45 / 2800/1500 |
| Volts/Ph/Hz | 208-230/1/60 | 208-230/1/60 |
| FLA | 0.34 | 0.34 |
| FILTER / FURNISHED | | |
| | NO | NO |
| Type Recommended | THROWAWAY | THROWAWAY |
| Recmd. Face Area (sq. ft.) ^⑥ | 5.3 | 5.3 |
| REFRIGERANT / Charge (lbs.) | | |
| | R410A / 7.75 | R410A / 7.75 |
| DIMENSIONS | | |
| | H X W X L | H X W X L |
| Crated (in.) | 47.86 / 47.4 / 61.75 | 47.86 / 47.4 / 61.75 |
| WEIGHT / Shipping / Net (lbs.) | | |
| | 653 / 525 | 653 / 525 |

① Certified in accordance with the Unitary Air-Conditioner Equipment certification program, which is based on AHRI Standard 210/240.

② All models are U L Listed. Ratings shown are for elevations up to 2000 ft. For higher elevations reduce ratings at a rate of 4% per 1000 ft. elevation.

③ Convertible to LPG.

④ This value is approximate. For more precise value, see Unit Nameplate.

⑤ Based on U.S. Government Standard Tests.

⑥ Filters must be installed in return air stream. Square footages listed are based on 300 f.p.m. face velocity. If permanent filters are used size per manufacturer's recommendation with a clean resistance of 0.05" W.C.

⑦ Sound Power values are not adjusted for AHRI 270-95 tonal corrections.

⑧ Standard Air — Dry Coil — Outdoor.

General Data

| MODEL | 4DCY4060C1115A | 4DCY4060A3120C |
|--|---------------------------|---------------------------|
| RATED Volts/PH/Hz | 208-230/1/60 | 208-230/3/60 |
| Performance Cooling BTUH ^① | 58000 | 57500 |
| Indoor Airflow (CFM) | 1785 | 1745 |
| Power Input (KW) | 4.83 | 5.478 |
| EER/SEER(BTU/Watt-Hr.) ^⑤ | 12.0 / 14.0 | 11.5 / 14.0 |
| Sound Power Rating [dB(A)] ^⑦ | 76 | 76 |
| HP Heating Performance | | |
| (High Temp.)BTUH / COP | 55000 / 3.6 | 54500 / 3.5 |
| Power Input (KW) | 4.48 | 4.56 |
| (Low Temp.) BTUH / COP | 35400 / 2.4 | 36400 / 2.48 |
| Power Input (KW) | 4.30 | 4.29 |
| HSPF (BTU / Watt-Hr.) | 8.0 | 8.0 |
| Gas Heating Performance ^② | | |
| (High) Input BTUH | 115000 | 120000 |
| Capacity BTUH | 93150 | 96000 |
| Temp. Rise — Min/Max (°F) | 30 / 60 | 30 / 60 |
| (Low) Input BTUH | 92000 | 90000 |
| Capacity BTUH | 74520 | 77500 |
| AFUE | 81 | 80.0 |
| Type of Gas ^③ | NATURAL/LP | NATURAL |
| Gas Pipe Size (in.) | 1/2 | 1/2 |
| POWER CONN.—V/PH/HZ | 208-230/1/60 | 208-230/3/60 |
| Min. Brch. Cir. Ampacity ^④ | 39.9 | 28.6 |
| Fuse Size — Max. (amps) | 60 | 45 |
| Fuse Size — Recmd. (amps) | 60 | 45 |
| COMPRESSOR | SCROLL | SCROLL |
| Volts/Ph/Hz | 208-230/1/60 | 208-230/3/60 |
| R.L. Amps — L.R. Amps | 25 / 134 | 16.0 / 110 |
| OUTDOOR COIL — TYPE | SPINE-FIN | SPINE-FIN |
| Rows/F.P.I. | 2 / 24 | 2 / 24 |
| Face Area (sq.ft.) | 23.07 | 23.57 |
| Tube Size (in.) | 3/8 | 3/8 |
| Refrigerant Control | EXPANSION VALVE | EXPANSION VALVE |
| INDOOR COIL — TYPE | PLATE FIN | PLATE FIN |
| Rows/F.P.I. | 4 / 15 | 4 / 15 |
| Face Area (sq.ft.) | 5.0 | 5.0 |
| Tube Size (in.) | 3/8 | 3/8 |
| Refrigerant Control | EXPANSION VALVE | EXPANSION VALVE |
| Drain Conn. Size (in.) | 3/4 FEMALE NPT | 3/4 FEMALE NPT |
| OUTDOOR FAN — TYPE | PROPELLER | PROPELLER |
| Dia. (in.) | 28.2 | 28.2 |
| Drive/No. Speeds | DIRECT / 1 | DIRECT / 1 |
| CFM @ 0.0 in. w.g. ^⑦ | 5710 | |
| Motor — HP/R.P.M. | 1/3 / 830 | 1/3 / 830 |
| Volts/Ph/Hz | 208-230/1/60 | 208-230/1/60 |
| F.L. Amps/L.R. Amps | 1.7 / 3.5 | 1.7 / 3.5 |
| INDOOR FAN — TYPE | CENTRIFUGAL | CENTRIFUGAL |
| Dia x Width (in.) | 11 X 10 | 11 X 10 |
| Drive/No. Speeds | DIRECT / VARIABLE | DIRECT / VARIABLE |
| CFM @ 0.0 in. w.g. ^⑤ | SEE FAN PERFORMANCE TABLE | SEE FAN PERFORMANCE TABLE |
| Motor — HP/R.P.M. | 1 / VARIABLE | 1 / VARIABLE |
| Volts/Ph/Hz | 208-230/1/60 | 208-230/1/60 |
| F.L. Amps/L.R. Amps | 6.9 / 6.9 | 6.9 / 6.9 |
| COMBUSTION FAN — TYPE | CENTRIFUGAL | CENTRIFUGAL |
| Drive/No. Speeds | DIRECT / 2 | DIRECT / 2 |
| Motor — HP/R.P.M. (High/Low) | 1/20 / 3350/2600 | 1/45 / 2800/1500 |
| Volts/Ph/Hz | 208-230/1/60 | 208-230/1/60 |
| FLA | 0.34 | 0.34 |
| FILTER / FURNISHED | NO | NO |
| Type Recommended | THROWAWAY | THROWAWAY |
| Recmd. Face Area (sq. ft.) ^⑥ | 6.7 | 6.7 |
| REFRIGERANT / Charge (lbs.) | R410A / 11.94 | R410A / 10.125 |
| DIMENSIONS | H X W X L | H X W X L |
| Crated (in.) | 51.86 / 47.4 / 61.75 | 51.86 / 47.4 / 61.75 |
| WEIGHT / Shipping / Net (lbs.) | 676 / 548 | 676 / 548 |

① Certified in accordance with the Unitary Air-Conditioner Equipment certification program, which is based on AHRI Standard 210/240.

② All models are U L Listed. Ratings shown are for elevations up to 2000 ft. For higher elevations reduce ratings at a rate of 4% per 1000 ft. elevation.

③ Convertible to LPG.

④ This value is approximate. For more precise value, see Unit Nameplate.

⑤ Based on U.S. Government Standard Tests.

⑥ Filters must be installed in return air stream. Square footages listed are based on 300 f.p.m. face velocity. If permanent filters are used size per manufacturer's recommendation with a clean resistance of 0.05" W.C.

⑦ Sound Power values are not adjusted for AHRI 270-95 tonal corrections.

⑧ Standard Air — Dry Coil — Outdoor.

Indoor Blower Performance

Indoor Fan Performance 4DCY4024

Horizontal Airflow

| 4DCY4024-HOR | DIPSWITCH SETTINGS | | | | External Static Pressure (in. wg) | | | | | | | | | | | | |
|-----------------|--------------------|-----|-----|-----|-----------------------------------|-----|-----|-----|-----|-----|-----|-----|-----|-----|-----|-----|--|
| AIRFLOW SETTING | 1 | 2 | 3 | 4 | | 0.0 | 0.1 | 0.2 | 0.3 | 0.4 | 0.5 | 0.6 | 0.7 | 0.8 | 0.9 | 1.0 | |
| 350 CFM/TON | OFF | OFF | OFF | ON | Watts | 52 | 66 | 89 | 115 | 140 | 164 | 186 | 206 | 229 | 259 | - | |
| | | | | | CFM | 706 | 716 | 727 | 733 | 731 | 719 | 700 | 679 | 662 | 659 | - | |
| 400 CFM/TON* | OFF | OFF | OFF | OFF | Watts | 72 | 94 | 120 | 148 | 177 | 207 | 233 | 254 | 267 | 290 | - | |
| | | | | | CFM | 786 | 793 | 805 | 813 | 813 | 806 | 793 | 780 | 778 | 799 | - | |
| 450 CFM/TON | OFF | OFF | ON | OFF | Watts | 80 | 99 | 125 | 153 | 182 | 211 | 243 | 284 | 342 | - | - | |
| | | | | | CFM | 860 | 862 | 877 | 892 | 903 | 904 | 897 | 884 | 869 | - | - | |

Down Airflow

| 4DCY4024-DOWN | DIPSWITCH SETTINGS | | | | External Static Pressure (in. wg) | | | | | | | | | | | | |
|-----------------|--------------------|-----|-----|-----|-----------------------------------|-----|-----|-----|-----|-----|-----|-----|-----|-----|-----|-----|--|
| AIRFLOW SETTING | 1 | 2 | 3 | 4 | | 0.0 | 0.1 | 0.2 | 0.3 | 0.4 | 0.5 | 0.6 | 0.7 | 0.8 | 0.9 | 1.0 | |
| 350 CFM/TON | OFF | OFF | OFF | ON | Watts | 35 | 70 | 90 | 108 | 131 | 160 | 188 | 204 | 225 | 250 | - | |
| | | | | | CFM | 695 | 729 | 734 | 728 | 721 | 715 | 705 | 679 | 680 | 685 | - | |
| 400 CFM/TON* | OFF | OFF | OFF | OFF | Watts | 79 | 87 | 105 | 129 | 155 | 180 | 206 | 232 | 264 | 306 | - | |
| | | | | | CFM | 846 | 807 | 802 | 810 | 816 | 813 | 803 | 794 | 800 | 846 | - | |
| 450 CFM/TON | OFF | OFF | ON | OFF | Watts | 86 | 102 | 127 | 156 | 185 | 213 | 242 | 275 | 319 | - | - | |
| | | | | | CFM | 884 | 870 | 882 | 899 | 909 | 907 | 895 | 886 | 898 | - | - | |

Indoor Fan Performance 4DCY4030

Horizontal Airflow

| 4DCY4030-HOR | DIPSWITCH SETTINGS | | | | External Static Pressure (in. wg) | | | | | | | | | | | | |
|-----------------|--------------------|-----|-----|-----|-----------------------------------|-----|------|------|------|------|------|------|------|------|-----|-----|--|
| AIRFLOW SETTING | 1 | 2 | 3 | 4 | | 0.0 | 0.1 | 0.2 | 0.3 | 0.4 | 0.5 | 0.6 | 0.7 | 0.8 | 0.9 | 1.0 | |
| 350 CFM/TON | OFF | OFF | OFF | ON | Watts | - | 112 | 155 | 176 | 199 | 231 | 270 | 299 | 289 | 197 | - | |
| | | | | | CFM | - | 867 | 905 | 904 | 899 | 904 | 914 | 907 | 840 | 650 | - | |
| 400 CFM/TON* | OFF | OFF | OFF | OFF | Watts | - | 157 | 192 | 222 | 249 | 276 | 306 | 343 | 389 | 448 | - | |
| | | | | | CFM | - | 997 | 1011 | 1012 | 1009 | 1006 | 1006 | 1006 | 1001 | 982 | - | |
| 450 CFM/TON | OFF | OFF | ON | OFF | Watts | - | 213 | 252 | 285 | 317 | 351 | 382 | 401 | 396 | - | - | |
| | | | | | CFM | - | 1125 | 1135 | 1132 | 1133 | 1138 | 1138 | 1110 | 1017 | - | - | |

Down Airflow

| 4DCY4030-DOWN | DIPSWITCH SETTINGS | | | | External Static Pressure (in. wg) | | | | | | | | | | | | |
|-----------------|--------------------|-----|-----|-----|-----------------------------------|-----|------|------|------|------|------|------|------|------|-----|-----|--|
| AIRFLOW SETTING | 1 | 2 | 3 | 4 | | 0.0 | 0.1 | 0.2 | 0.3 | 0.4 | 0.5 | 0.6 | 0.7 | 0.8 | 0.9 | 1.0 | |
| 350 CFM/TON | OFF | OFF | OFF | ON | Watts | - | 126 | 152 | 182 | 211 | 237 | 263 | 292 | 333 | 397 | 497 | |
| | | | | | CFM | - | 883 | 900 | 911 | 911 | 901 | 883 | 863 | 849 | 854 | 890 | |
| 400 CFM/TON* | OFF | OFF | OFF | OFF | Watts | - | 158 | 196 | 224 | 251 | 283 | 318 | 344 | 345 | 295 | 162 | |
| | | | | | CFM | - | 987 | 1004 | 1006 | 1004 | 1001 | 994 | 977 | 936 | 851 | 697 | |
| 450 CFM/TON | OFF | OFF | ON | OFF | Watts | - | 218 | 254 | 288 | 321 | 354 | 390 | 431 | 480 | - | - | |
| | | | | | CFM | - | 1118 | 1128 | 1132 | 1131 | 1127 | 1127 | 1142 | 1183 | - | - | |

*Factory Default Setting

Auxiliary Heating Airflow, horizontal or downflow from .2 to .6" wg.

| 4DCY4024 | | | | |
|-----------------|-------|-----------|-----------------|------------|
| Switch Settings | | Selection | Nominal Airflow | |
| | | | Low Stage | High Stage |
| 7-OFF | 8-OFF | A | 600 | 850 |
| 7-ON | 8-OFF | B | 625 | 900 |
| 7-OFF | 8-ON | C | 650 | 925 |
| 7-ON | 8-ON | D | 700 | 975 |

| 4DCY4030 | | | | |
|-----------------|-------|-----------|-----------------|------------|
| Switch Settings | | Selection | Nominal Airflow | |
| | | | Low Stage | High Stage |
| 7-OFF | 8-OFF | A | 725 | 1000 |
| 7-ON | 8-OFF | B | 775 | 1075 |
| 7-OFF | 8-ON | C | 850 | 1150 |
| 7-ON | 8-ON | D | 925 | 1250 |

Indoor Blower Performance

Indoor Fan Performance 4DCY4036

Horizontal Airflow

| 4DCY4036-HOR | DIPSWITCH SETTINGS | | | | External Static Pressure (in. wg) | | | | | | | | | | | |
|-----------------|--------------------|-----|-----|-----|-----------------------------------|------|------|------|------|------|------|------|------|------|-----|-----|
| AIRFLOW SETTING | 1 | 2 | 3 | 4 | | 0.0 | 0.1 | 0.2 | 0.3 | 0.4 | 0.5 | 0.6 | 0.7 | 0.8 | 0.9 | 1.0 |
| 350 CFM/TON | OFF | OFF | OFF | ON | Watts | 162 | 173 | 197 | 226 | 256 | 285 | 313 | 343 | 360 | - | - |
| | | | | | CFM | 1058 | 1062 | 1063 | 1063 | 1062 | 1060 | 1057 | 1053 | 1010 | - | - |
| 400 CFM/TON* | OFF | OFF | OFF | OFF | Watts | 179 | 230 | 265 | 296 | 329 | 366 | 403 | 431 | 436 | - | - |
| | | | | | CFM | 1179 | 1196 | 1204 | 1206 | 1205 | 1203 | 1199 | 1194 | 1185 | - | - |
| 450 CFM/TON | OFF | OFF | ON | OFF | Watts | 318 | 336 | 365 | 399 | 435 | 469 | 502 | 533 | - | - | - |
| | | | | | CFM | 1390 | 1376 | 1370 | 1366 | 1361 | 1354 | 1349 | 1351 | - | - | - |

Down Airflow

| 4DCY4036-DOWN | DIPSWITCH SETTINGS | | | | External Static Pressure (in. wg) | | | | | | | | | | | |
|-----------------|--------------------|-----|-----|-----|-----------------------------------|------|------|------|------|------|------|------|------|------|-----|-----|
| AIRFLOW SETTING | 1 | 2 | 3 | 4 | | 0.0 | 0.1 | 0.2 | 0.3 | 0.4 | 0.5 | 0.6 | 0.7 | 0.8 | 0.9 | 1.0 |
| 350 CFM/TON | OFF | OFF | OFF | ON | Watts | 169 | 182 | 210 | 243 | 273 | 301 | 331 | 370 | 433 | - | - |
| | | | | | CFM | 1025 | 1062 | 1068 | 1063 | 1060 | 1061 | 1064 | 1055 | 1015 | - | - |
| 400 CFM/TON* | OFF | OFF | OFF | OFF | Watts | 225 | 253 | 283 | 315 | 348 | 381 | 414 | 449 | 484 | - | - |
| | | | | | CFM | 1187 | 1201 | 1203 | 1201 | 1198 | 1197 | 1194 | 1184 | 1157 | - | - |
| 450 CFM/TON | OFF | OFF | ON | OFF | Watts | 339 | 357 | 390 | 424 | 455 | 483 | 516 | 571 | - | - | - |
| | | | | | CFM | 1391 | 1377 | 1377 | 1375 | 1366 | 1352 | 1344 | 1360 | - | - | - |

Indoor Fan Performance 4DCY4042

Horizontal Airflow

| 4DCY4042-HOR | DIPSWITCH SETTINGS | | | | External Static Pressure (in. wg) | | | | | | | | | | | |
|-----------------|--------------------|-----|-----|-----|-----------------------------------|-----|------|------|------|------|------|------|------|------|------|------|
| AIRFLOW SETTING | 1 | 2 | 3 | 4 | | 0.0 | 0.1 | 0.2 | 0.3 | 0.4 | 0.5 | 0.6 | 0.7 | 0.8 | 0.9 | 1.0 |
| 350 CFM/TON | OFF | OFF | OFF | ON | Watts | - | 160 | 185 | 214 | 245 | 277 | 308 | 339 | 368 | 396 | 423 |
| | | | | | CFM | - | 1206 | 1211 | 1213 | 1215 | 1215 | 1214 | 1212 | 1208 | 1201 | 1190 |
| 400 CFM/TON* | OFF | OFF | OFF | OFF | Watts | - | 231 | 261 | 292 | 325 | 359 | 394 | 431 | 467 | 503 | 536 |
| | | | | | CFM | - | 1389 | 1398 | 1405 | 1409 | 1410 | 1408 | 1403 | 1399 | 1396 | 1399 |
| 450 CFM/TON | OFF | OFF | ON | OFF | Watts | - | 326 | 362 | 393 | 421 | 450 | 482 | 517 | 556 | 597 | - |
| | | | | | CFM | - | 1582 | 1592 | 1593 | 1587 | 1577 | 1566 | 1557 | 1553 | 1556 | - |

Down Airflow

| 4DCY4042-DOWN | DIPSWITCH SETTINGS | | | | External Static Pressure (in. wg) | | | | | | | | | | | |
|-----------------|--------------------|-----|-----|-----|-----------------------------------|-----|------|------|------|------|------|------|------|------|------|------|
| AIRFLOW SETTING | 1 | 2 | 3 | 4 | | 0.0 | 0.1 | 0.2 | 0.3 | 0.4 | 0.5 | 0.6 | 0.7 | 0.8 | 0.9 | 1.0 |
| 350 CFM/TON | OFF | OFF | OFF | ON | Watts | - | 176 | 203 | 232 | 262 | 294 | 325 | 357 | 388 | 417 | 443 |
| | | | | | CFM | - | 1207 | 1214 | 1217 | 1216 | 1213 | 1208 | 1201 | 1193 | 1185 | 1177 |
| 400 CFM/TON* | OFF | OFF | OFF | OFF | Watts | - | 253 | 290 | 323 | 355 | 386 | 420 | 455 | 491 | 526 | 558 |
| | | | | | CFM | - | 1405 | 1411 | 1413 | 1412 | 1407 | 1399 | 1389 | 1377 | 1366 | 1357 |
| 450 CFM/TON | OFF | OFF | ON | OFF | Watts | - | 367 | 379 | 409 | 446 | 485 | 522 | 556 | 591 | 633 | - |
| | | | | | CFM | - | 1599 | 1577 | 1570 | 1569 | 1566 | 1560 | 1550 | 1537 | 1528 | - |

*Factory Default Setting

Auxiliary Heating Airflow, horizontal or downflow from .2 to .6" wg.

| 4DCY4036 | | | | |
|-----------------|-------|-----------|-----------------|------------|
| Switch Settings | | Selection | Nominal Airflow | |
| | | | Low Stage | High Stage |
| 7-OFF | 8-OFF | A | 725 | 1000 |
| 7-ON | 8-OFF | B | 775 | 1075 |
| 7-OFF | 8-ON | C | 850 | 1150 |
| 7-ON | 8-ON | D | 925 | 1250 |

| 4DCY4042 | | | | |
|-----------------|-------|-----------|-----------------|------------|
| Switch Settings | | Selection | Nominal Airflow | |
| | | | Low Stage | High Stage |
| 7-OFF | 8-OFF | A | 1075 | 1375 |
| 7-ON | 8-OFF | B | 1100 | 1450 |
| 7-OFF | 8-ON | C | 1150 | 1500 |
| 7-ON | 8-ON | D | 1200 | 1575 |

Indoor Blower Performance

Indoor Fan Performance 4DCY4048

Horizontal Airflow

| 4DCY4048-HOR | DIPSWITCH SETTINGS | | | | External Static Pressure (in. wg) | | | | | | | | | | | |
|-----------------|--------------------|-----|-----|-----|-----------------------------------|------|------|------|------|------|------|------|------|------|------|-----|
| AIRFLOW SETTING | 1 | 2 | 3 | 4 | | 0.0 | 0.1 | 0.2 | 0.3 | 0.4 | 0.5 | 0.6 | 0.7 | 0.8 | 0.9 | 1.0 |
| 350 CFM/TON | OFF | OFF | OFF | ON | Watts | 187 | 232 | 264 | 291 | 318 | 347 | 379 | 413 | 446 | 472 | - |
| | | | | | CFM | 1355 | 1387 | 1396 | 1392 | 1382 | 1370 | 1360 | 1351 | 1341 | 1326 | - |
| 400 CFM/TON* | OFF | OFF | OFF | OFF | Watts | 315 | 324 | 352 | 389 | 428 | 464 | 498 | 529 | 563 | 606 | - |
| | | | | | CFM | 1603 | 1581 | 1577 | 1580 | 1583 | 1583 | 1577 | 1567 | 1558 | 1556 | - |
| 450 CFM/TON | OFF | OFF | ON | OFF | Watts | 301 | 431 | 507 | 552 | 584 | 615 | 651 | 694 | 739 | 779 | - |
| | | | | | CFM | 1752 | 1794 | 1812 | 1816 | 1812 | 1806 | 1800 | 1797 | 1793 | 1785 | - |

Down Airflow

| 4DCY4048-DOWN | DIPSWITCH SETTINGS | | | | External Static Pressure (in. wg) | | | | | | | | | | | |
|-----------------|--------------------|-----|-----|-----|-----------------------------------|------|------|------|------|------|------|------|------|------|------|-----|
| AIRFLOW SETTING | 1 | 2 | 3 | 4 | | 0.0 | 0.1 | 0.2 | 0.3 | 0.4 | 0.5 | 0.6 | 0.7 | 0.8 | 0.9 | 1.0 |
| 350 CFM/TON | OFF | OFF | OFF | ON | Watts | 208 | 254 | 284 | 312 | 343 | 379 | 414 | 437 | 460 | 490 | - |
| | | | | | CFM | 1337 | 1393 | 1398 | 1388 | 1383 | 1390 | 1399 | 1384 | 1380 | 1370 | - |
| 400 CFM/TON* | OFF | OFF | OFF | OFF | Watts | 302 | 349 | 386 | 423 | 465 | 509 | 552 | 583 | 599 | 628 | - |
| | | | | | CFM | 1574 | 1580 | 1585 | 1589 | 1594 | 1598 | 1601 | 1597 | 1584 | 1556 | - |
| 450 CFM/TON | OFF | OFF | ON | OFF | Watts | 501 | 523 | 555 | 592 | 631 | 672 | 714 | 760 | 800 | 845 | - |
| | | | | | CFM | 1847 | 1823 | 1817 | 1818 | 1820 | 1819 | 1817 | 1820 | 1815 | 1810 | - |

Indoor Fan Performance 4DCY4060

Horizontal Airflow

| 4DCY4060-HOR | DIPSWITCH SETTINGS | | | | External Static Pressure (in. wg) | | | | | | | | | | | |
|-----------------|--------------------|-----|-----|-----|-----------------------------------|------|------|------|------|------|------|------|------|------|------|-----|
| AIRFLOW SETTING | 1 | 2 | 3 | 4 | | 0.0 | 0.1 | 0.2 | 0.3 | 0.4 | 0.5 | 0.6 | 0.7 | 0.8 | 0.9 | 1.0 |
| 350 CFM/TON | OFF | OFF | OFF | ON | Watts | 394 | 427 | 464 | 504 | 548 | 591 | 633 | 668 | - | - | - |
| | | | | | CFM | 1673 | 1772 | 1799 | 1793 | 1779 | 1771 | 1767 | 1756 | - | - | - |
| 400 CFM/TON* | OFF | OFF | OFF | OFF | Watts | 695 | 642 | 660 | 710 | 764 | 811 | 849 | 893 | 966 | 1108 | - |
| | | | | | CFM | 2054 | 2036 | 2031 | 2032 | 2033 | 2031 | 2023 | 2012 | 2002 | 2000 | - |

Down Airflow

| 4DCY4060-DOWN | DIPSWITCH SETTINGS | | | | External Static Pressure (in. wg) | | | | | | | | | | | |
|-----------------|--------------------|-----|-----|-----|-----------------------------------|------|------|------|------|------|------|------|------|------|------|-----|
| AIRFLOW SETTING | 1 | 2 | 3 | 4 | | 0.0 | 0.1 | 0.2 | 0.3 | 0.4 | 0.5 | 0.6 | 0.7 | 0.8 | 0.9 | 1.0 |
| 350 CFM/TON | OFF | OFF | OFF | ON | Watts | 443 | 461 | 493 | 532 | 571 | 607 | 642 | 680 | - | - | - |
| | | | | | CFM | 1796 | 1741 | 1726 | 1725 | 1722 | 1712 | 1698 | 1692 | - | - | - |
| 400 CFM/TON* | OFF | OFF | OFF | OFF | Watts | 740 | 697 | 715 | 763 | 819 | 866 | 892 | 894 | 872 | 835 | - |
| | | | | | CFM | 2012 | 1987 | 1979 | 1977 | 1976 | 1969 | 1950 | 1913 | 1852 | 1759 | - |

*Factory Default Setting

Auxiliary Heating Airflow, horizontal or downflow from .2 to .6" wg.

| 4DCY4048C *090 | | | | |
|-----------------|-------|-----------|-----------------|------------|
| Switch Settings | | Selection | Nominal Airflow | |
| | | | Low Stage | High Stage |
| 7-OFF | 8-OFF | A | 1075 | 1375 |
| 7-ON | 8-OFF | B | 1100 | 1450 |
| 7-OFF | 8-ON | C | 1150 | 1500 |
| 7-ON | 8-ON | D | 1200 | 1575 |

* can be 1 or 3

| 4DCY4060C1115 | | | | |
|-----------------|-------|-----------|-----------------|------------|
| Switch Settings | | Selection | Nominal Airflow | |
| | | | Low Stage | High Stage |
| 7-OFF | 8-OFF | A | 1375 | 1800 |
| 7-ON | 8-OFF | B | 1450 | 1900 |

Typical Field Wiring

4DCY FIELD WIRING DIAGRAM

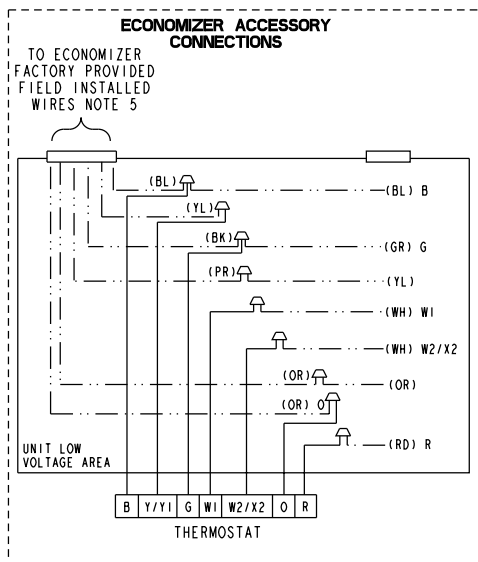
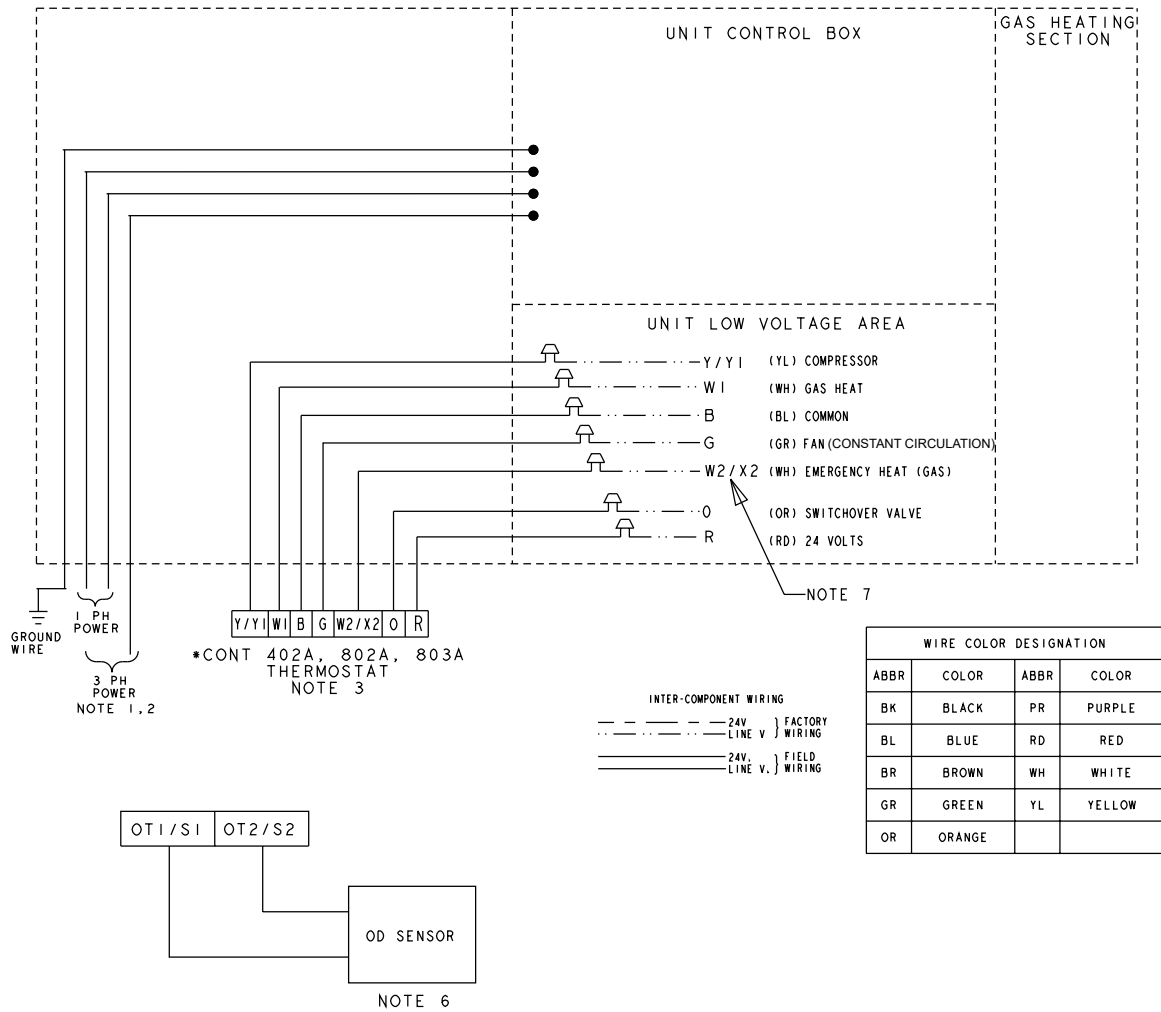

NOTES:

1. FUSED DISCONNECT SIZE, POWER WIRING AND GROUNDING OF EQUIPMENT MUST COMPLY WITH CODES.
2. BE SURE POWER SUPPLY AGREES WITH EQUIPMENT NAMEPLATE.
3. LOW VOLTAGE WIRING TO BE 18 AWG MINIMUM CONDUCTOR.
4. SEE UNIT DIAGRAM FOR ELECTRICAL CONNECTION DETAILS.
5. WHEN THE BAYECON101A, 102A, 200A OR 201A ECONOMIZER IS INSTALLED, THE BAYRLAY004 RELAY ACCESSORY KIT IS REQUIRED TO INTERFACE THE ECONOMIZER TO THE HEAT PUMP FOR PROPER SYSTEM OPERATION.
6. THE OUTDOOR SENSOR SHOULD BE LOCATED IN AN AREA WHICH WILL PROVIDE A REPRESENTATIVE OUTDOOR TEMPERATURE.
7. A FIELD INSTALLED JUMPER WIRE MUST BE PLACED BETWEEN W1 AND W2/X2 AT THE UNIT FOR COMFORT CONTROLS *CONT 802A AND 803A TO PROPERLY FUNCTION.

Typical Wiring

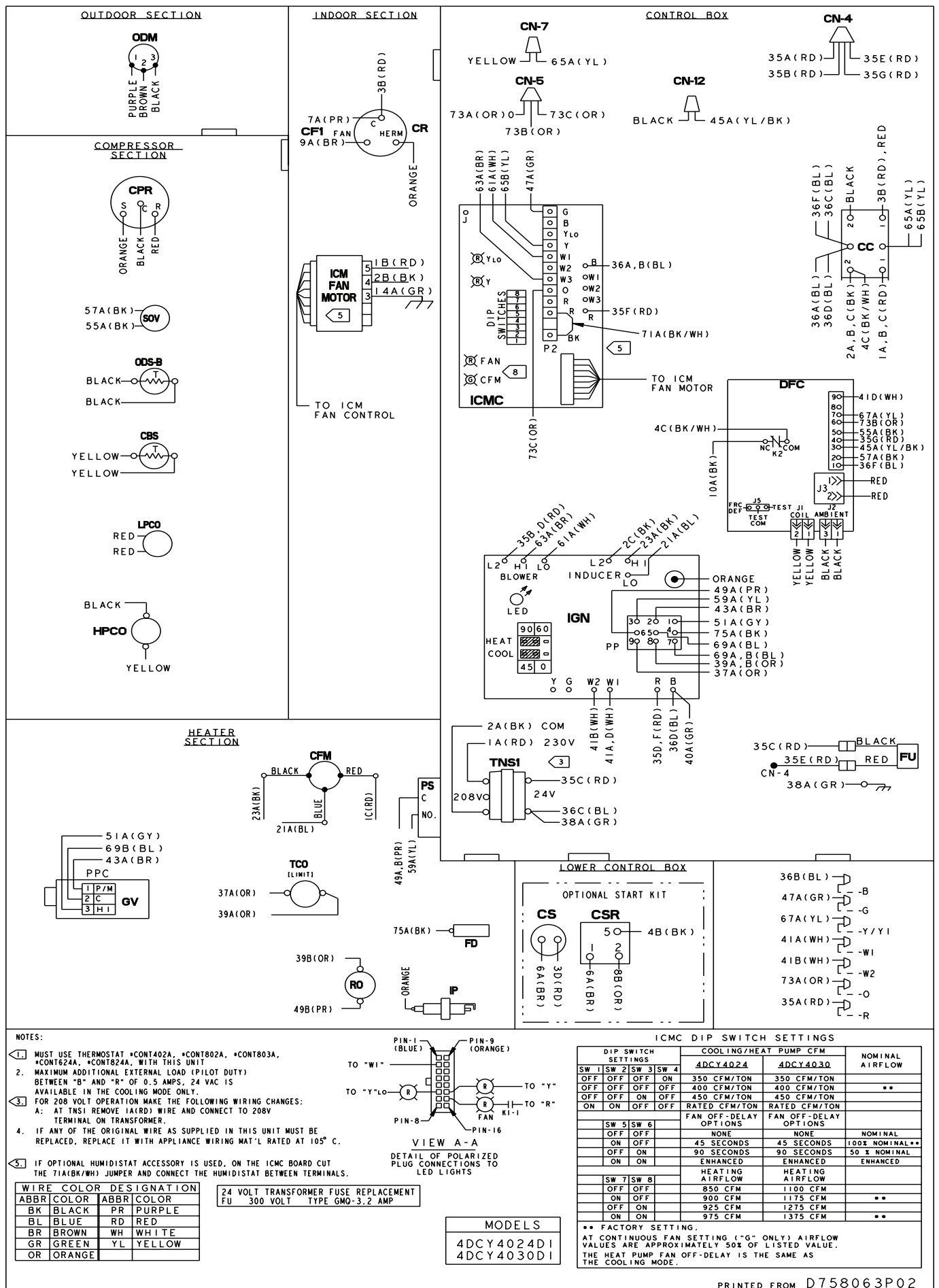

Typical Wiring

CAUTION-NOT SUITABLE FOR USE ON SYSTEMS EXCEEDING 150 VOLTS TO GROUND.
ATTENTION: NE CONVIENT PAS POUR LES INSTALLATIONS DE PLUS DE 150V. A TERRE.

UNIT FACTORY WIRED FOR 230V.
SEE WIRING DIAGRAM NOTES FOR REQUIRED WIRING CHANGES WHEN INSTALLED ON A 208V POWER SUPPLY.
POWER SUPPLY PER LOCAL CODES SEE NAMEPLATE FOR LINE VOLTAGE

MODELS
4DCY4024D1
4DCY4030D1

WARNING
HAZARDOUS VOLTAGE!
DISCONNECT ALL ELECTRIC POWER BEFORE SERVICING.
FAILURE TO DISCONNECT POWER SUPPLY BEFORE SERVICING CAN CAUSE SEVERE PERSONAL INJURY OR DEATH.

AVERTISSEMENT
VOLTAGE HASARDEUX!
DECONNECTEZ TOUTES LES SOURCES ELECTRIQUES INCLUANT LES DISJONCTEURS SITUES A DISTANCE AVANT D'EFFECTUER L'ENTRETIEN. FAUTE DE DECONNECTER LA SOURCE ELECTRIQUE AVANT D'EFFECTUER L'ENTRETIEN PEUT ENTRAINER DES BLESSURES CORPORELLES SEVERES OU LA MORT.

CAUTION
USE COPPER CONDUCTORS ONLY!
UNIT TERMINALS ARE NOT DESIGNED TO ACCEPT OTHER TYPES OF CONDUCTORS. FAILURE TO DO SO MAY CAUSE DAMAGE TO THE EQUIPMENT.

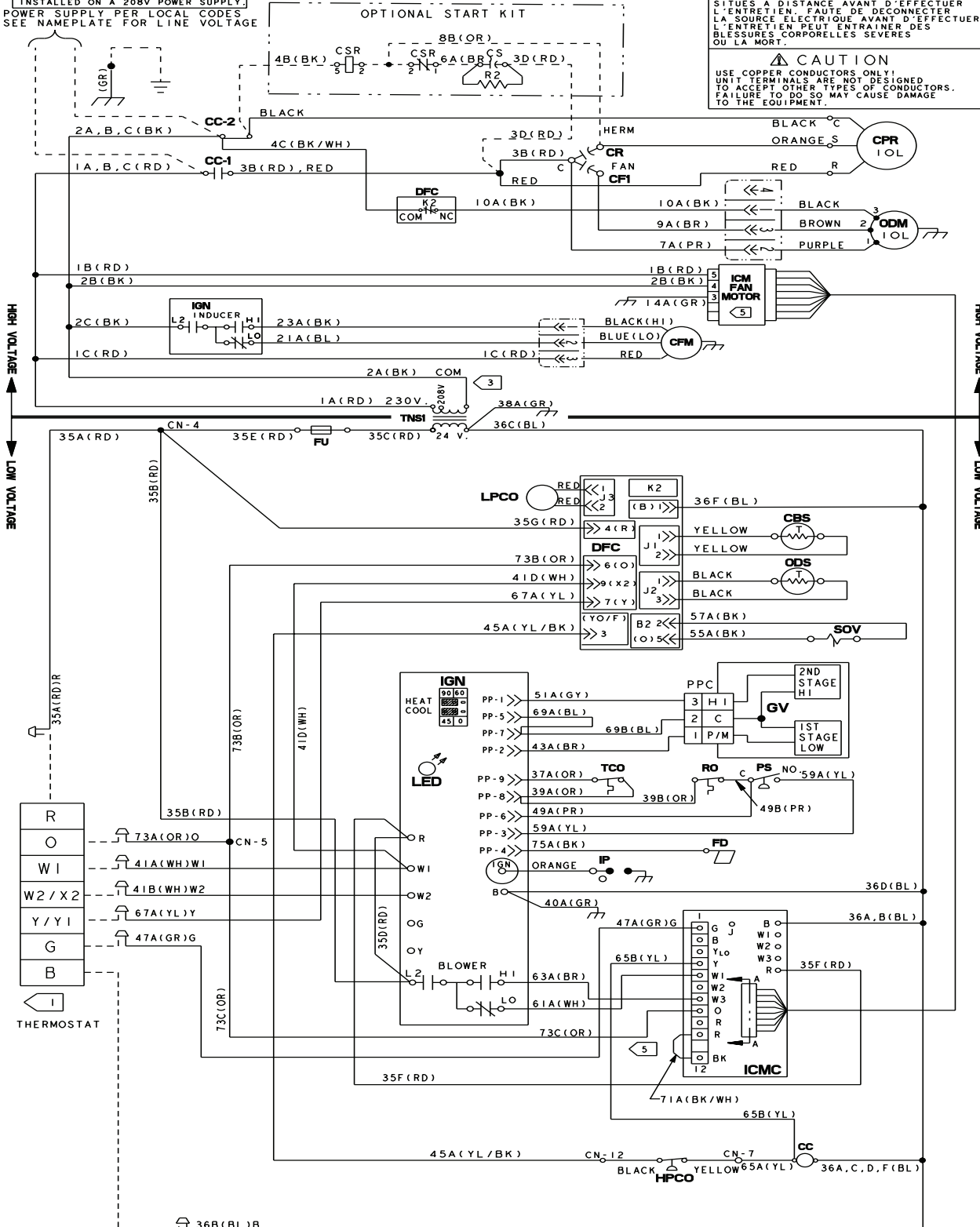

24 VOLT TRANSFORMER FUSE REPLACEMENT
FU 300 VOLT TYPE GMO-3.2 AMP

MUST USE THERMOSTAT
•CONT402A, •CONT802A,
•CONT803A, •CONT624A,
•CONT824A, WITH THIS UNIT

IGN JUMPER SETTINGS

| | | |
|----------------------|----------------------|---------------------------|
| COOL (45/0) | HEAT (90/60) | FAN ON DELAY |
| FAN OFF DELAY 45 SEC | FAN OFF DELAY 90 SEC | FAN ON DELAY 45 SEC FIXED |
| 0 SEC | 60 SEC | |
| *FACTORY SETTING | | |

IGN LED DIAGNOSTIC INDICATOR

| | |
|---------------|---------------------------------|
| FLASHING SLOW | NORMAL - CALL FOR HEAT |
| CONTINUOUS ON | CHECK POWER/INTERNAL FAILURE |
| 2 FLASHES | SYSTEM LOCKOUT (NO FLAME) |
| 3 FLASHES | PRESSURE SWITCH PROBLEM |
| 4 FLASHES | HIGH LIMIT (TCO) OPEN |
| 5 FLASHES | FLAME SENSED WITH GAS VALVE OFF |
| 6 FLASHES | FLAME ROLLOUT SWITCH (FL) OPEN |
| 7 FLASHES | W1 & W2 SWAPPED |

PRINTED FROM D758064P02

Typical Wiring

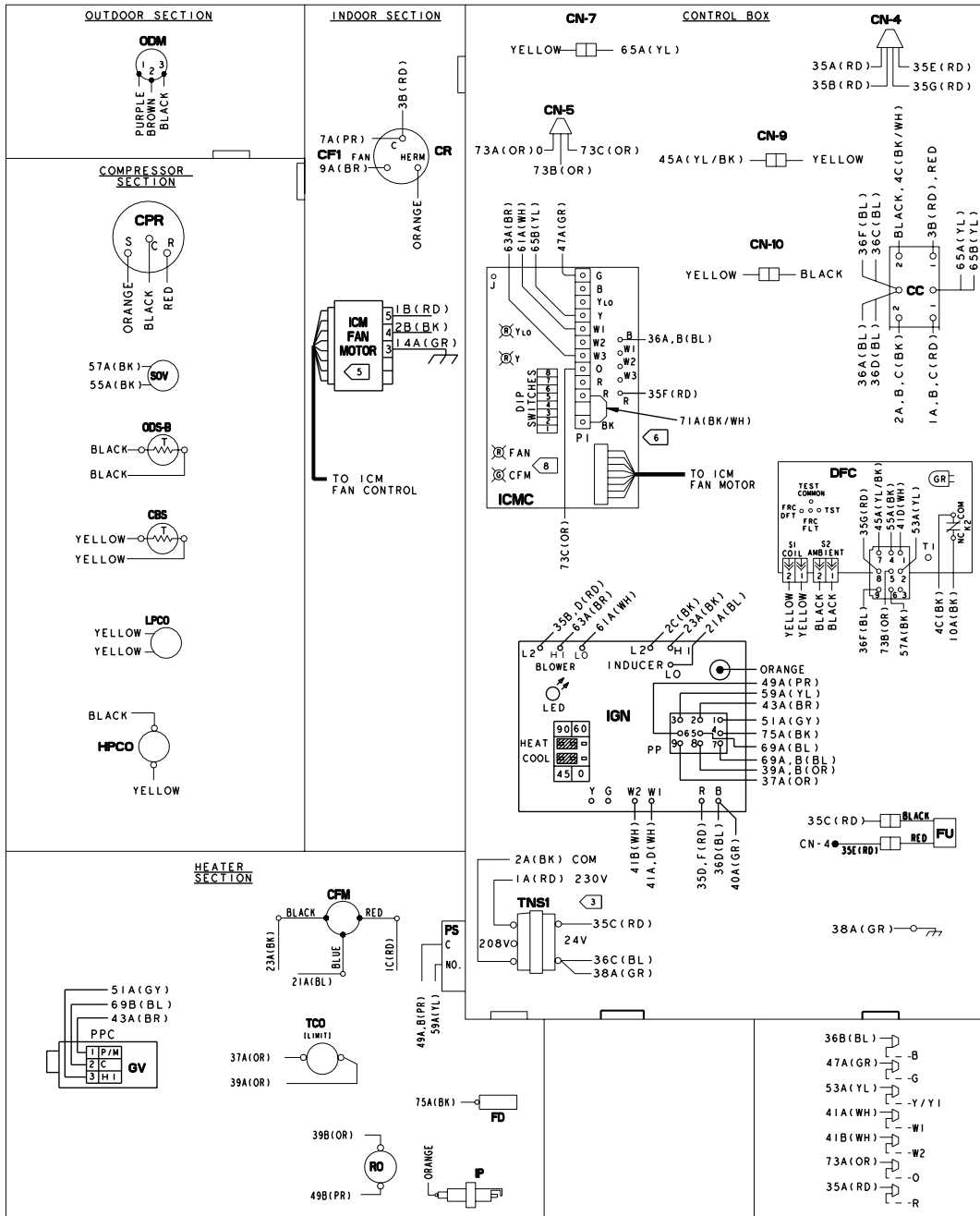

NOTES:

- CONNECTIONS SHOWN ARE FOR A TYPICAL THERMOSTAT. SEE SCHEMATIC SUPPLIED WITH THERMOSTAT FOR PROPER CONNECTIONS. LOW VOLTAGE WIRING TO UNIT MAY BE NEC CLASS 2 AND MUST BE A MIN. OF 18 A.W.G. SET THERMOSTAT HEAT ANTICIPATOR TO .3 AMPS. MAXIMUM ADDITIONAL EXTERNAL LOAD (PILOT DUTY) BETWEEN "B" AND "R" OF 0.5 AMPS. 24 VAC IS AVAILABLE IN THE COOLING MODE ONLY.
- FOR 208 VOLT OPERATION MAKE THE FOLLOWING WIRING CHANGES:
A: AT TNS1 REMOVE (XRD) WIRE AND CONNECT TO 208V TERMINAL ON TRANSFORMER.
- IF ANY OF THE ORIGINAL WIRE AS SUPPLIED IN THIS UNIT MUST BE REPLACED, REPLACE IT WITH APPLIANCE WIRING MAT'L RATED AT 105° C.
- "T" TERMINAL IS NOT CONNECTED WHEN AN ELECTRONIC THERMOSTAT IS USED.
- IF OPTIONAL HUMIDISTAT ACCESSORY IS USED, ON THE ICMC BOARD CUT THE 71A(BK/WH) JUMPER AND CONNECT THE HUMIDISTAT BETWEEN TERMINALS.

MODELS
4DCY4036C1

VIEW A-A
DETAIL OF POLARIZED PLUG CONNECTIONS TO LED LIGHTS

WIRE COLOR DESIGNATION

| ABBR | COLOR | ABBR | COLOR |
|------|--------|------|--------|
| BK | BLACK | PR | PURPLE |
| BL | BLUE | RD | RED |
| BR | BROWN | WH | WHITE |
| GR | GREEN | YL | YELLOW |
| OR | ORANGE | | |

ICMC DIP SWITCH SETTINGS

| DIP SWITCH SETTINGS | COOLING/HEAT PUMP CFM | NOMINAL AIRFLOW |
|-----------------------|-----------------------|-----------------|
| SW 1 SW 2 SW 3 SW 4 | 350 CFM/TON | |
| OFF OFF OFF OFF | 400 CFM/TON | ** |
| OFF OFF ON OFF | 450 CFM/TON | |
| ON ON OFF OFF | RATED CFM/TON | |
| FAN OFF-DELAY OPTIONS | | |
| SW 5 SW 6 | NONE | NOMINAL |
| OFF OFF | 45 SECONDS | 100% NOMINAL ** |
| ON OFF | 90 SECONDS | 50% NOMINAL |
| ON ON | ENHANCED | ENHANCED |
| ELECTRIC HEAT AIRFLOW | | |
| SW 7 SW 8 | 350 CFM/TON | |
| OFF OFF | 400 CFM/TON | ** |
| ON OFF | | |

** FACTORY SETTING.
AT CONTINUOUS FAN SETTING ("G" ONLY) AIRFLOW VALUES ARE APPROXIMATELY 50% OF LISTED VALUE. THE HEAT PUMP FAN OFF-DELAY IS THE SAME AS THE COOLING MODE.

DEVICE DESCRIPTION LINE

| DEVICE | DESCRIPTION | LINE |
|--------|-------------------------------------|--------|
| CBS | COIL BOTTOM SENSOR | 35 |
| CC | COMPRESSOR CONTACTOR COIL | 68 |
| CFI | OUTDOOR FAN CAPACITOR | 19 |
| CFM | COMBUSTION FAN MOTOR | 24 |
| CN | CONNECTOR OR WIRE NUT | |
| CPR | COMPRESSOR | 14 |
| CR | COMPRESSOR RUN CAPACITOR | 14 |
| DFC | DEFROST CONTROL | 31-39 |
| FD | FLAME DETECTOR | 52 |
| FU | FUSE | 29 |
| GV | GAS VALVE | 45 |
| HPCO | HIGH PRESSURE SWITCH | 68 |
| ICM | INTEGRATED COMMUTATED MOTOR | 22 |
| ICMC | INTEGRATED COMMUTATED MOTOR CONTROL | 56-64 |
| IGN | IGNITION CONTROL MODULE | 23, 53 |
| IGL | INTERNAL OVERLOAD | 14 |
| IP | IGNITOR PROBE | 47 |
| LED | IGN DIAGNOSTICS INDICATOR | 68 |
| LPDO | LOW PRESSURE SWITCH | 18 |
| ODM | OUTDOOR FAN MOTOR | 37 |
| ODS | OUTDOOR AMBIENT SENSOR | 37 |
| PP | POLARIZED PLUG | 43-52 |
| PS | PRESSURE SWITCH | 48 |
| RO | ROLLOUT LIMIT | 48 |
| SOV | SWITCHOVER VALVE | 40 |
| TCO | TEMPERATURE LIMIT SWITCH | 48 |
| TNS1 | CONTROL POWER TRANSFORMER | 28 |

Typical Wiring

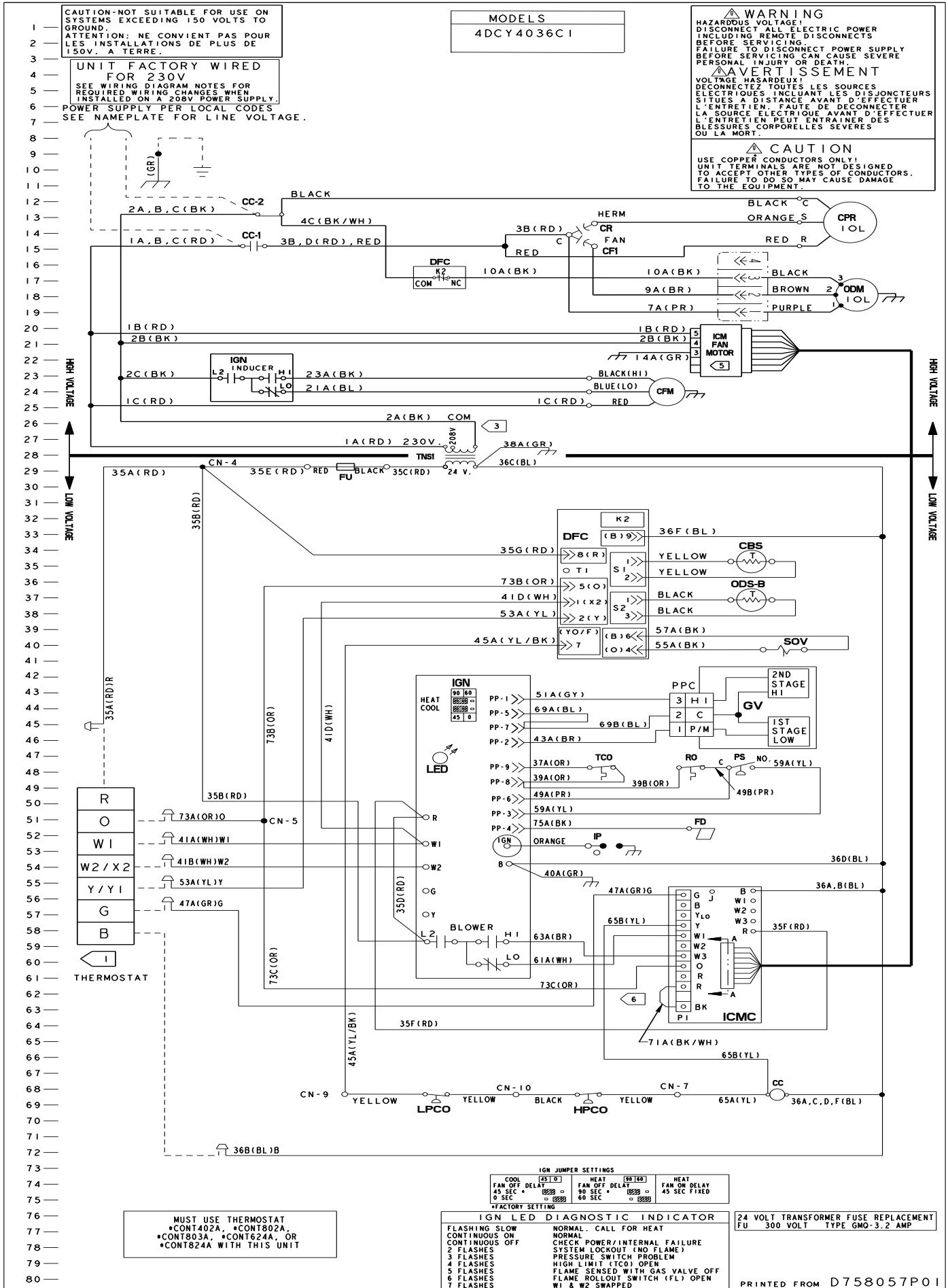

Typical Wiring

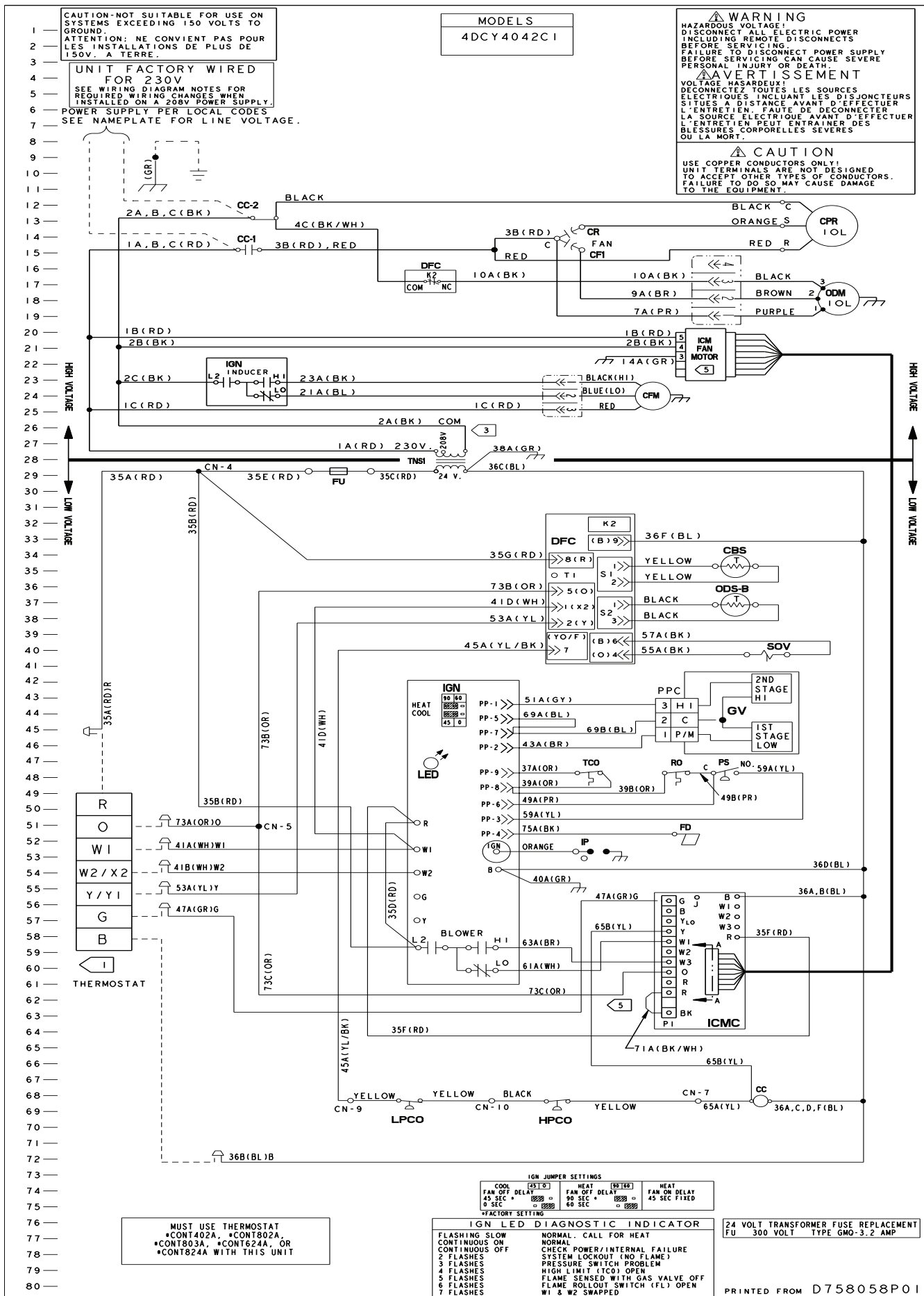

Typical Wiring

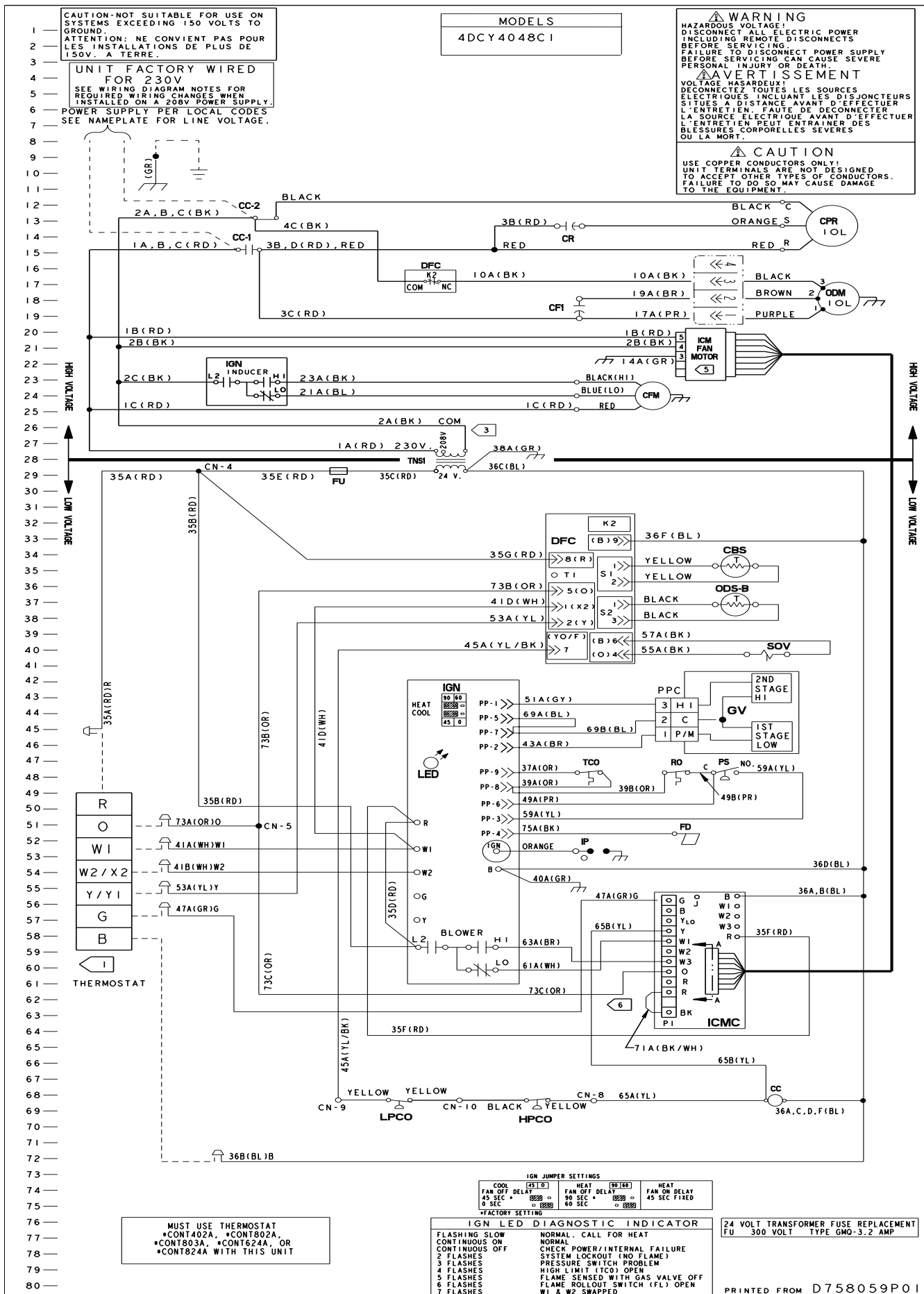

CAUTION-NOT SUITABLE FOR USE ON SYSTEMS EXCEEDING 150 VOLTS TO GROUND
ATTENTION: NE CONVIENT PAS POUR LES INSTALLATIONS DE PLUS DE 150V. A TERRE.

UNIT FACTORY WIRED FOR 230V
SEE WIRING DIAGRAM NOTES FOR REQUIRED WIRING CHANGES WHEN INSTALLED ON A 208V POWER SUPPLY
POWER SUPPLY PER LOCAL CODES SEE NAMEPLATE FOR LINE VOLTAGE.

MODELS
4DCY4048C1

WARNING
HAZARDOUS VOLTAGE!
DISCONNECT ALL ELECTRIC POWER INCLUDING REMOTE DISCONNECTS BEFORE SERVICING.
FAILURE TO DISCONNECT POWER SUPPLY BEFORE SERVICING CAN CAUSE SEVERE PERSONAL INJURY OR DEATH.

AVERTISSEMENT
VOLTAGE HASARDEUX!
DECONNECTEZ TOUTES LES SOURCES ELECTRIQUES INCLUANT LES DISJONCTEURS SITUES A DISTANCE AVANT D'EFFECTUER L'ENTRETIEN. FAUTE DE DECONNECTER LA SOURCE ELECTRIQUE AVANT D'EFFECTUER L'ENTRETIEN PEUT ENTRAÎNER DES BLESSURES CORPORELLES SEVERES OU LA MORT.

CAUTION
USE COPPER CONDUCTORS ONLY!
UNIT TERMINALS ARE NOT DESIGNED TO ACCEPT OTHER TYPES OF CONDUCTORS. FAILURE TO DO SO MAY CAUSE DAMAGE TO THE EQUIPMENT.

HIGH VOLTAGE
LOW VOLTAGE

HIGH VOLTAGE
LOW VOLTAGE

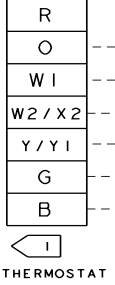

| IGN JUMPER SETTINGS | | |
|---------------------|---------------|--------------|
| COOL | FAN OFF DELAY | HEAT |
| 45 SEC | 90 SEC | FAN ON DELAY |
| 0 SEC | 60 SEC | 45 SEC FIXED |

| IGN LED DIAGNOSTIC INDICATOR | |
|------------------------------|---------------------------------|
| FLASHING SLOW | NORMAL. CALL FOR HEAT |
| CONTINUOUS ON | CHECK POWER/INTERNAL FAILURE |
| CONTINUOUS OFF | SYSTEM LOCKOUT (NO FLAME) |
| 2 FLASHES | PRESSURE SWITCH PROBLEM |
| 3 FLASHES | HIGH LIMIT (TCO) OPEN |
| 4 FLASHES | FLAME SENSED WITH GAS VALVE OFF |
| 5 FLASHES | FLAME ROLL-OUT SWITCH (FL) OPEN |
| 6 FLASHES | W1 & W2 SWAPPED |
| 7 FLASHES | |

24 VOLT TRANSFORMER FUSE REPLACEMENT
FU 300 VOLT TYPE GMD-3.2 AMP

PRINTED FROM D758059P01

Typical Wiring

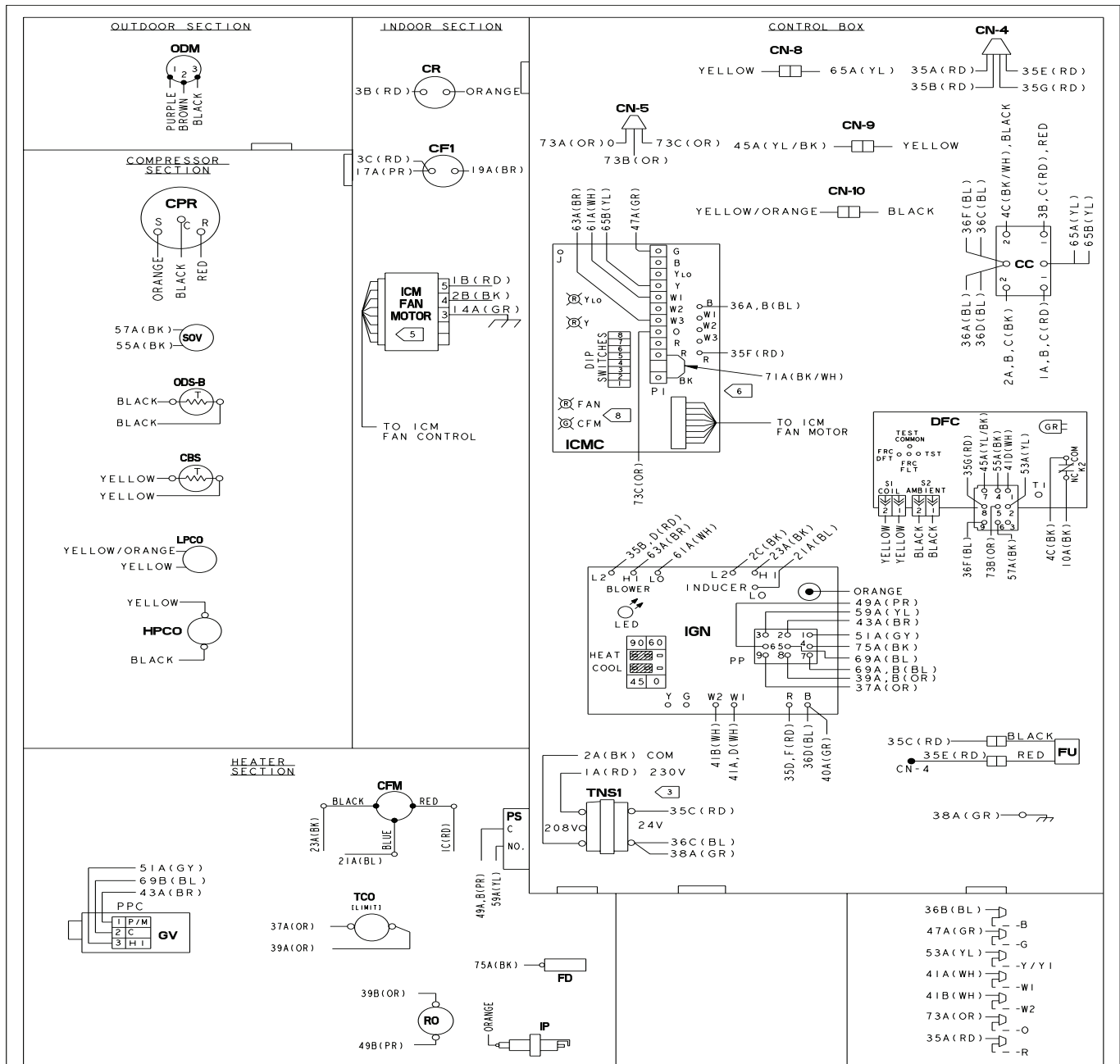

- NOTES:**
- CONNECTIONS SHOWN ARE FOR A TYPICAL THERMOSTAT. SEE SCHEMATIC SUPPLIED WITH THERMOSTAT FOR PROPER CONNECTIONS. LOW VOLTAGE WIRING TO UNIT MAY BE NEC CLASS 2 AND MUST BE A MIN. OF 18 A.W.G. SET THERMOSTAT HEAT ANTICIPATOR TO .3 AMPS.
 - MAXIMUM ADDITIONAL EXTERNAL LOAD (PILOT DUTY) BETWEEN "B" AND "R" OF 0.5 AMPS, 24 VAC IS AVAILABLE IN THE COOLING MODE ONLY.
 - FOR 208 VOLT OPERATION MAKE THE FOLLOWING WIRING CHANGES:
A: AT TNS1 REMOVE 1A(RD) WIRE AND CONNECT TO 208V TERMINAL ON TRANSFORMER.
 - IF ANY OF THE ORIGINAL WIRE AS SUPPLIED IN THIS UNIT MUST BE REPLACED, REPLACE IT WITH APPLIANCE WIRING MAT' L RATED AT 105° C.
 - "T" TERMINAL IS NOT CONNECTED WHEN AN ELECTRONIC THERMOSTAT IS USED.
 - IF OPTIONAL HUMIDISTAT ACCESSORY IS USED, ON THE ICMC BOARD CUT THE 71A(BK/WH) JUMPER AND CONNECT THE HUMIDISTAT BETWEEN TERMINALS.

| WIRE COLOR DESIGNATION | | | |
|------------------------|--------|------|--------|
| ABBR | COLOR | ABBR | COLOR |
| BK | BLACK | PR | PURPLE |
| BL | BLUE | RD | RED |
| BR | BROWN | WH | WHITE |
| GR | GREEN | YL | YELLOW |
| OR | ORANGE | | |

| DEVICE | DESCRIPTION | LINE |
|--------|-------------------------------------|--------|
| CBS | COIL BOTTOM SENSOR | 35 |
| CC | COMPRESSOR CONTACTOR COIL | 68 |
| CF1 | OUTDOOR FAN CAPACITOR | 19 |
| CFM | COMBUSTION FAN MOTOR | 24 |
| CN | CONNECTOR OR WIRE NUT | |
| CPR | COMPRESSOR | 14 |
| CR | COMPRESSOR RUN CAPACITOR | 14 |
| CS | COMPRESSOR START CAPACITOR | |
| CSR | COMPRESSOR START RELAY COIL | |
| DFC | DEFROST CONTROL | 31-39 |
| FD | FLAME DETECTOR | 52 |
| FU | FUSE | 29 |
| GV | GAS VALVE | 45 |
| HPCO | HIGH PRESSURE SWITCH | 68 |
| ICM | INTEGRATED COMMUTATED MOTOR | 22 |
| ICMC | INTEGRATED COMMUTATED MOTOR CONTROL | 56-64 |
| IGN | IGNITION CONTROL MODULE | 23, 53 |
| IGL | INTERNAL OVERLOAD | 14 |
| IP | IGNITOR PROBE | 53 |
| LED | IGN DIAGNOSTICS INDICATOR | 47 |
| LPCO | LOW PRESSURE SWITCH | 68 |
| ODM | OUTDOOR FAN MOTOR | 18 |
| ODS | OUTDOOR AMBIENT SENSOR | 37 |
| PP | POLARIZED PLUG | 43-52 |
| PS | PRESSURE SWITCH | 48 |
| RO | ROLLOUT LIMIT | 48 |
| SOV | SWITCHOVER VALVE | 40 |
| TCO | TEMPERATURE LIMIT SWITCH | 48 |
| TNS1 | CONTROL POWER TRANSFORMER | 28 |

MODELS
4DCY4060C1

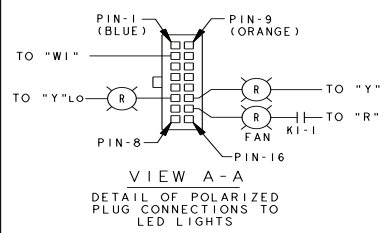

| ICMC DIP SWITCH SETTINGS | | | |
|--------------------------|-------------------------|-----------------|----|
| DIP SWITCH SETTINGS | COOLING / HEAT PUMP CFM | NOMINAL AIRFLOW | |
| SW 1 SW 2 SW 3 SW 4 | 350 CFM/TON | | |
| OFF OFF OFF ON | 400 CFM/TON | | ** |
| ON ON OFF OFF | RATED CFM/TON | | |
| FAN OFF-DELAY OPTIONS | | | |
| SW 5 SW 6 | NONE | NOMINAL | |
| ON OFF | 45 SECONDS | 100% NOMINAL | ** |
| OFF ON | 90 SECONDS | 50% NOMINAL | |
| ON ON | ENHANCED | ENHANCED | |
| AUX. HEAT AIRFLOW | | | |
| SW 7 SW 8 | 350 CFM/TON | | |
| OFF OFF | 400 CFM/TON | | ** |
| ON OFF | 400 CFM/TON | | |

** FACTORY SETTING.
AT CONTINUOUS FAN SETTING ("G" ONLY) AIRFLOW VALUES ARE APPROXIMATELY 50% OF LISTED VALUE.
THE HEAT PUMP FAN OFF-DELAY IS THE SAME AS THE COOLING MODE.

Typical Wiring

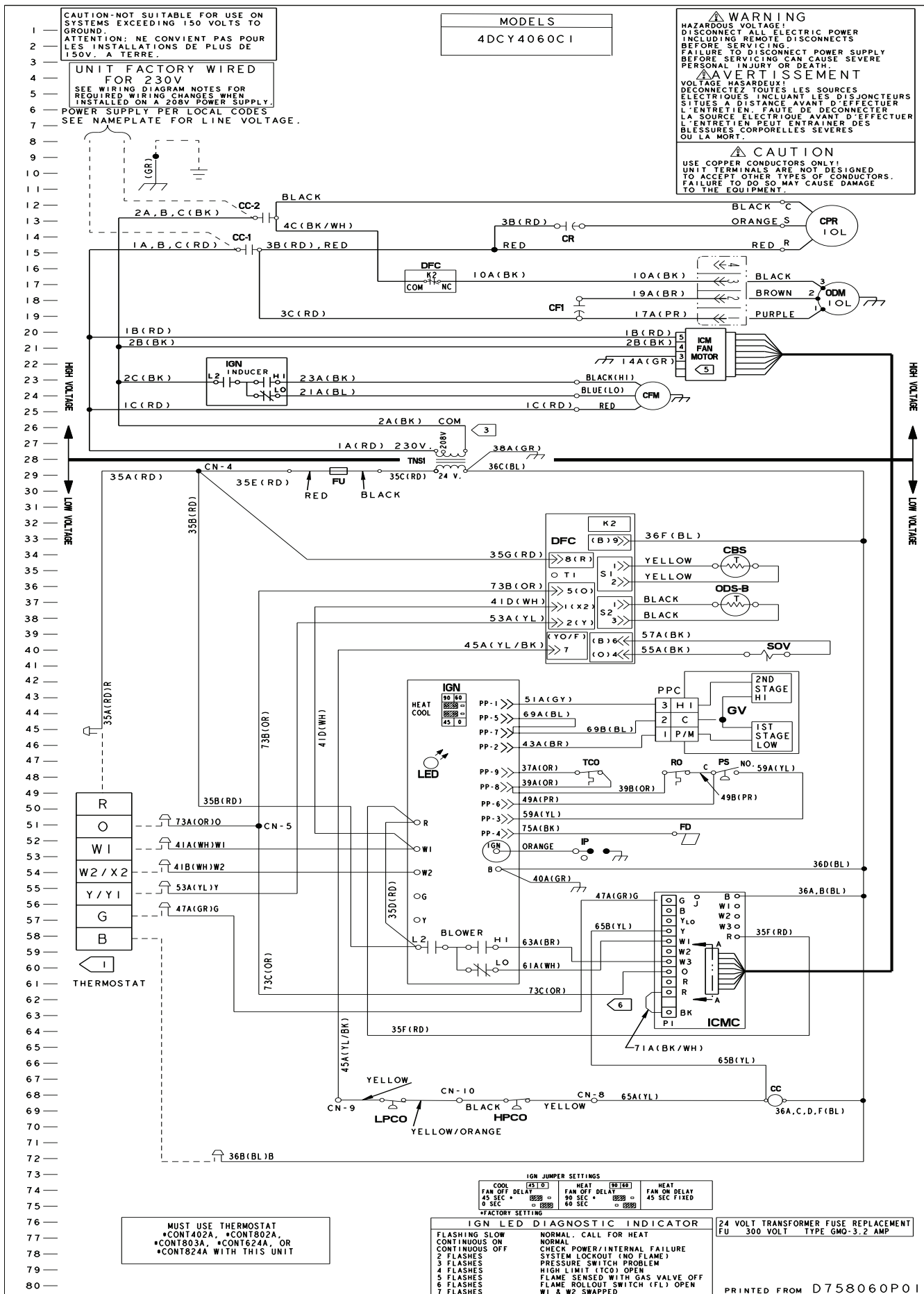

Optional Equipment

BAYCURB050A Full Perimeter Roof Mounting Curb for *****024-036

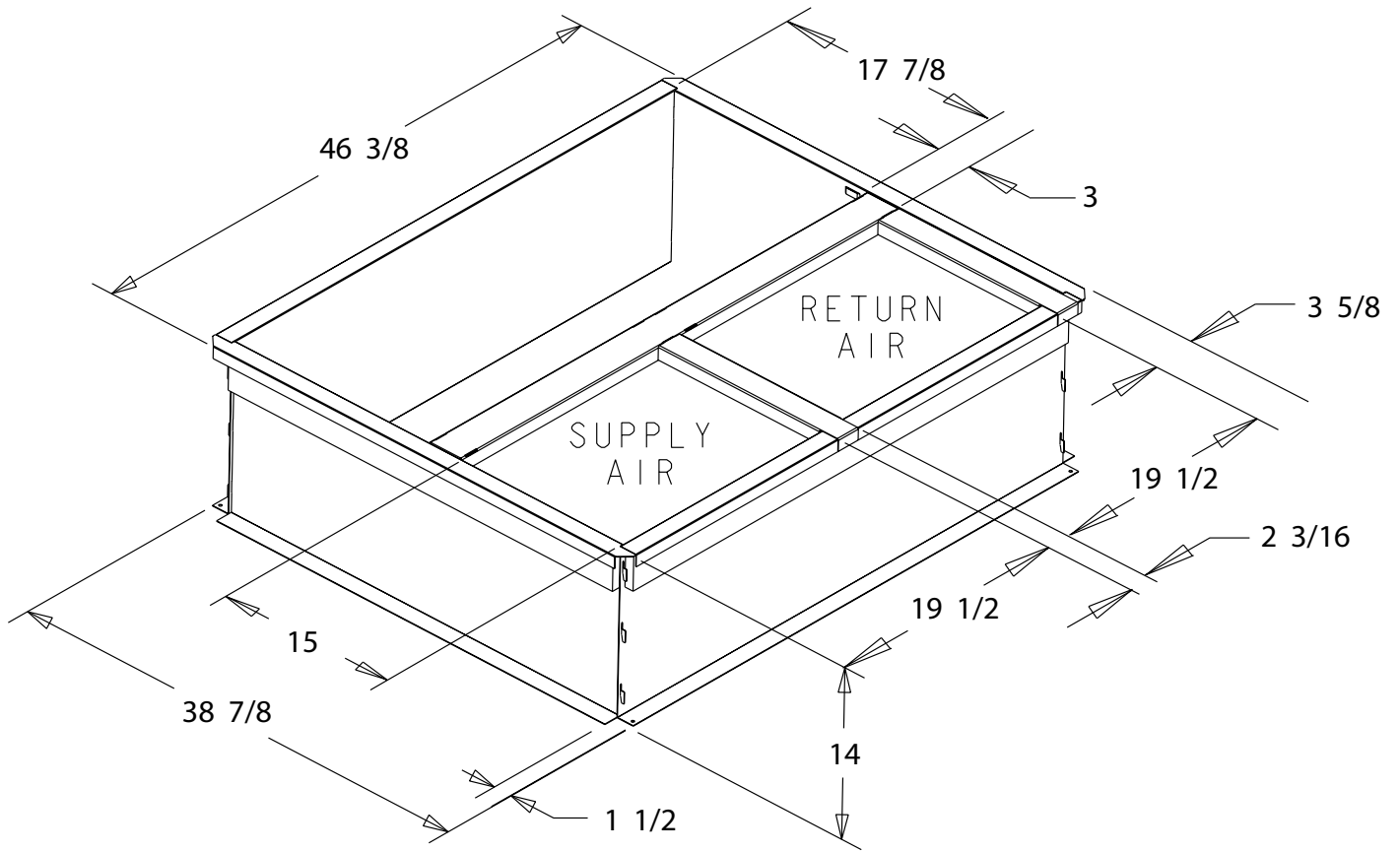

The drawings on this page are prepared by the manufacturer in order to provide detail regarding job layout only. These drawings are not intended to be used as a basis to construct, build or modify the items depicted in the drawings. The manufacturer is not responsible for the unauthorized use of these drawings and expressly disclaims any liability for damages resulting from such unauthorized use.

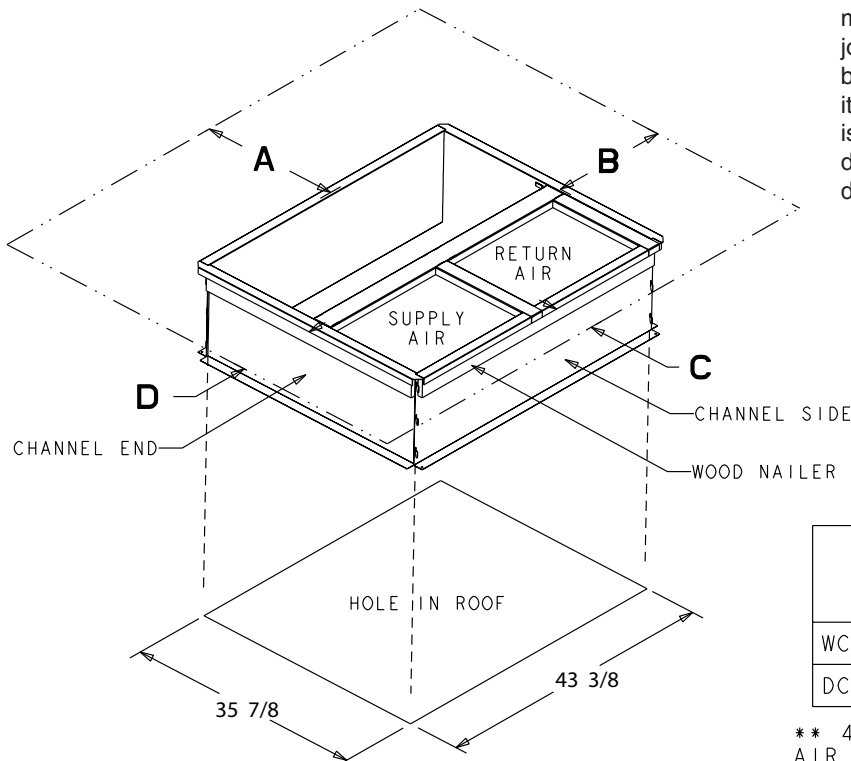

| | SERVICE CLEARANCE DIMENSIONS | | | |
|---------|------------------------------|-------|---------|-------|
| | A | B | C | D |
| WC*/TC* | 42.00 | 36.00 | 12.00** | 24.00 |
| DC*/YC* | 42.00 | 36.00 | 12.00** | 36.00 |

** 42.00 WITH ECONOMIZER WITH 25% FRESH AIR ACCESSORY

Optional Equipment

BAYCURB051A Full Perimeter Roof Mounting Curb for *****042-060

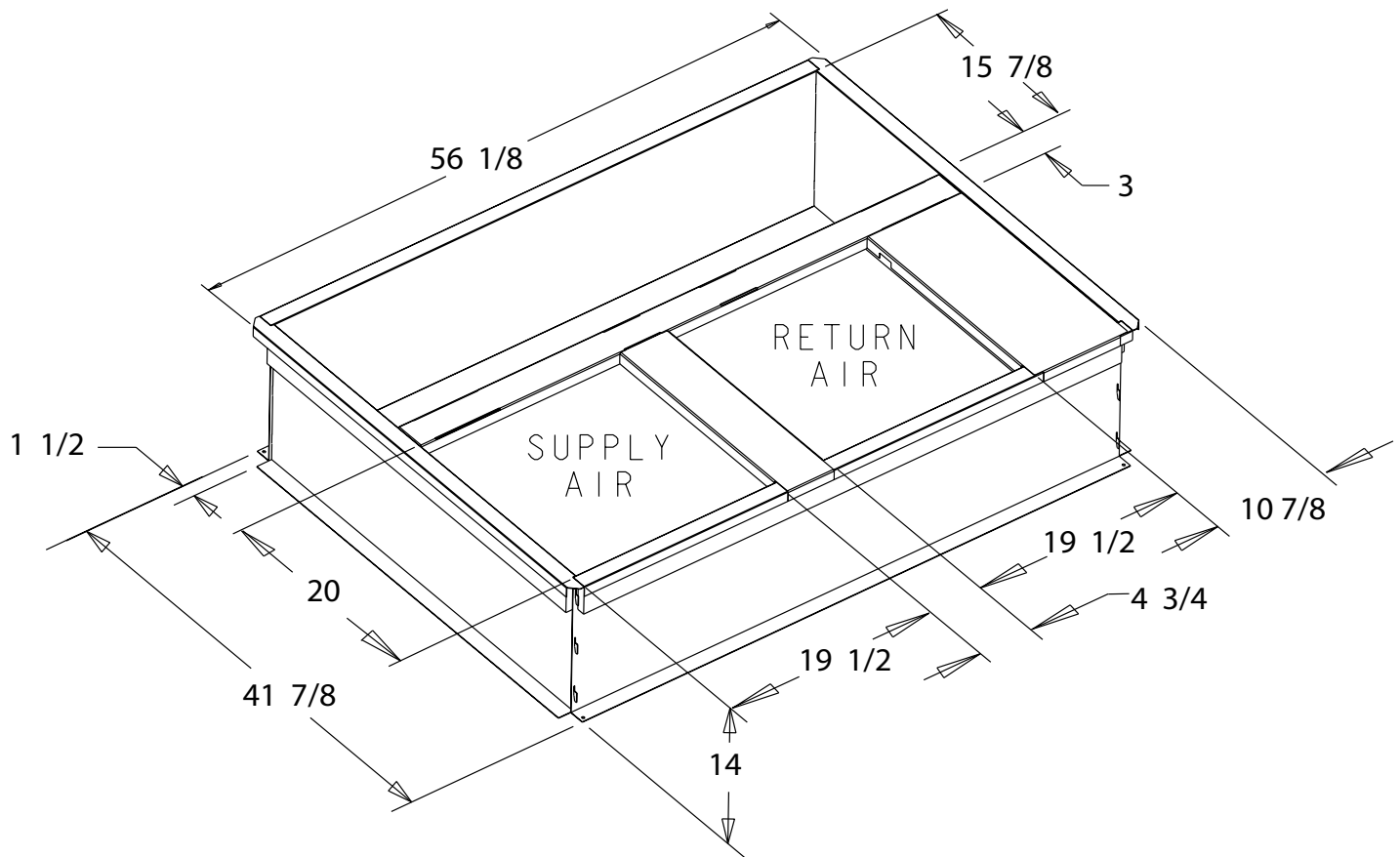

The drawings on this page are prepared by the manufacturer in order to provide detail regarding job layout only. These drawings are not intended to be used as a basis to construct, build or modify the items depicted in the drawings. The manufacturer is not responsible for the unauthorized use of these drawings and expressly disclaims any liability for damages resulting from such unauthorized use.

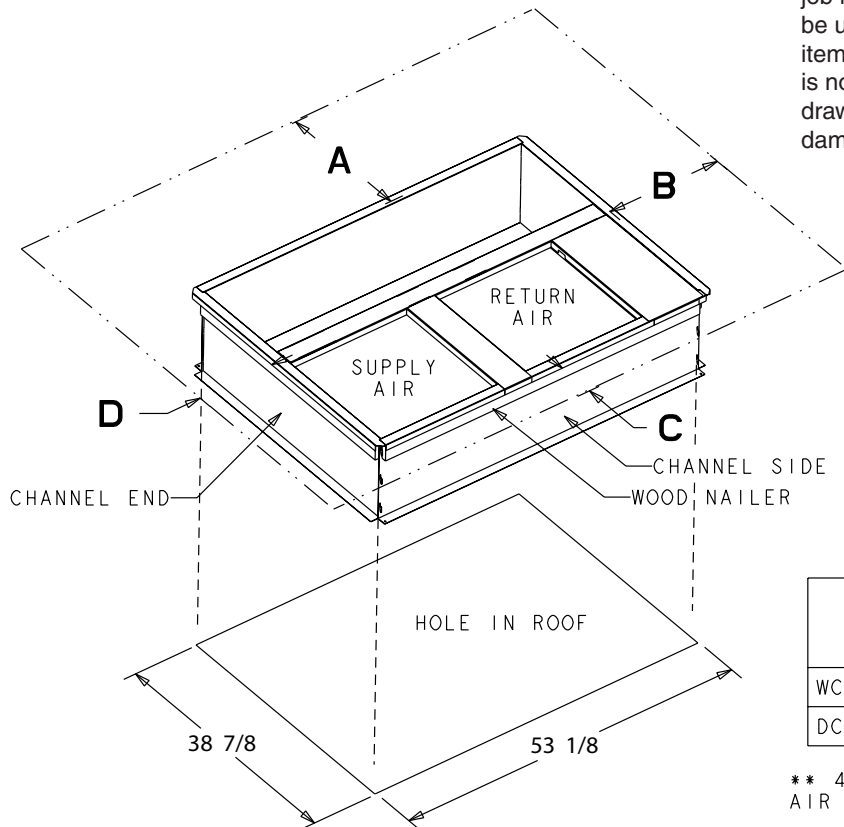

| | SERVICE CLEARANCE DIMENSIONS | | | |
|---------|------------------------------|-------|---------|-------|
| | A | B | C | D |
| WC*/TC* | 42.00 | 36.00 | 12.00** | 24.00 |
| DC*/YC* | 42.00 | 36.00 | 12.00** | 36.00 |

** 42.00 WITH ECONOMIZER WITH 25% FRESH AIR ACCESSORY

Optional Equipment

**BAYFLTR101, 201B, 1" – 2" Filter Rack
(Mounts in Filter/Coil Section)**

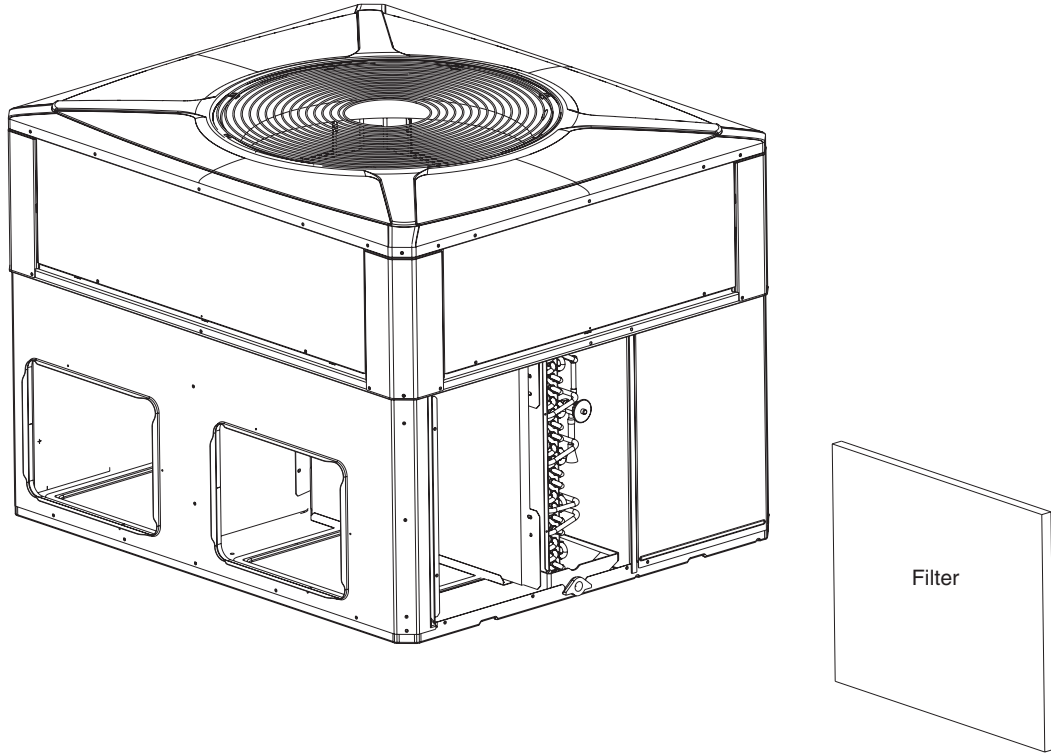

**BAYACCDOR1A & BAYACCDOR2A Hinged Filter Access Door
Replaces Filter/Coil Access Panel**

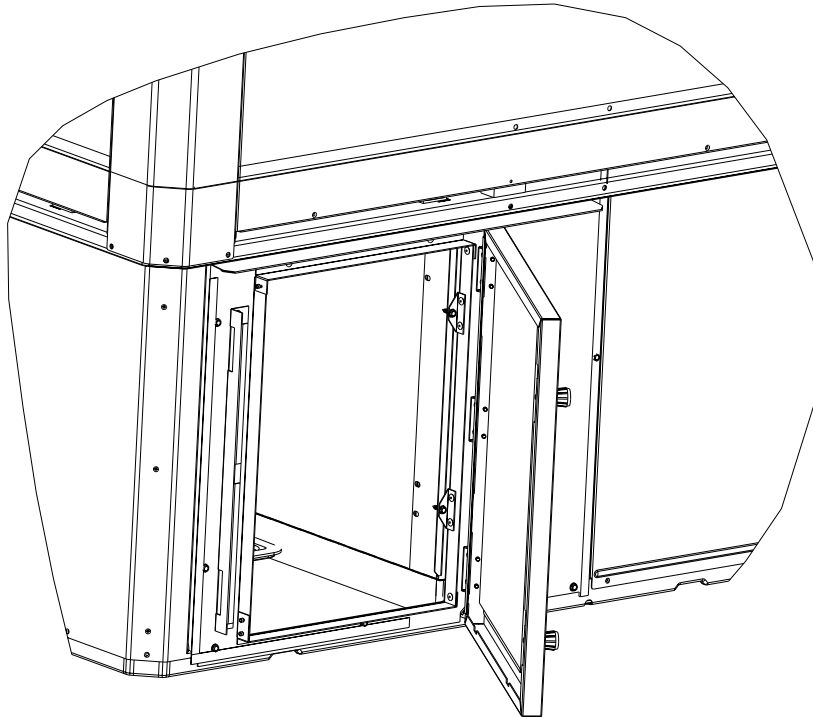

The drawings on this page are prepared by the manufacturer in order to provide detail regarding job layout only. These drawings are not intended to be used as a basis to construct, build or modify the items depicted in the drawings. The manufacturer is not responsible for the unauthorized use of these drawings and expressly disclaims any liability for damages resulting from such unauthorized use.

Optional Equipment

BAYECON101,102A Down Discharge Economizer and Rain Hood (Mounts Over Horizontal Return Air Opening)

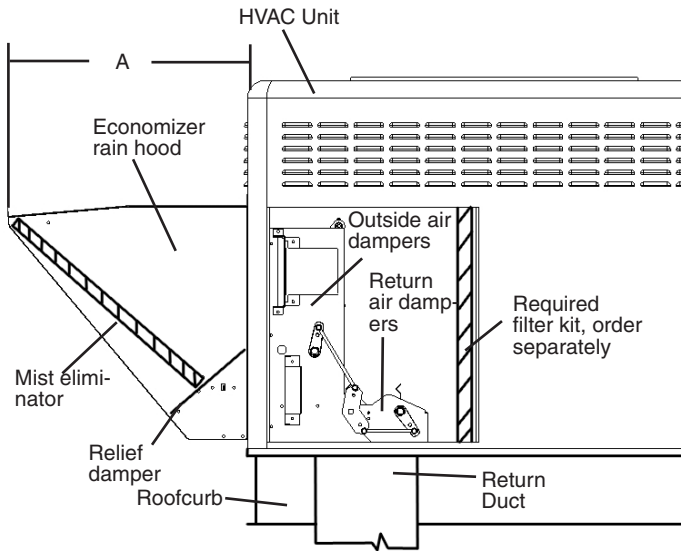

| Economizer | Unit Application Models | A |
|-------------|------------------------------|---------|
| BAYECON101A | 4TC*,WC*,YC*,DC* *018-036 | 20.125" |
| BAYECON102A | 4TC*,WC*,YC*,DC* *042-060 | 24.375" |

BAYECON200,201A Horizontal Economizer and Rain Hood

The drawings on this page are prepared by the manufacturer in order to provide detail regarding job layout only. These drawings are not intended to be used as a basis to construct, build or modify the items depicted in the drawings. The manufacturer is not responsible for the unauthorized use of these drawings and expressly disclaims any liability for damages resulting from such unauthorized use.

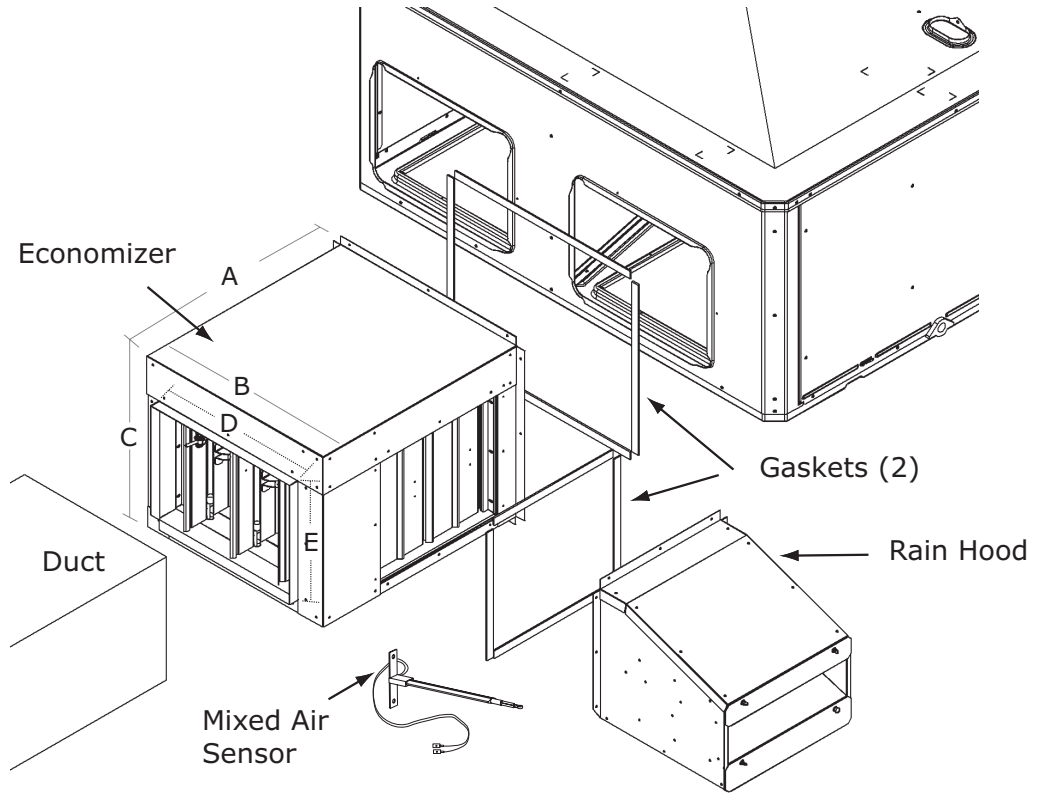

| Economizer | A | B | C | D | E | F |
|--------------|-----|-----------|---------|-----------|-----------|---------|
| BAYECON200AA | 22" | 20" | 16 7/8" | 15 11/16" | 11 11/16" | 15" |
| BAYECON201AA | 26" | 22 21/32" | 19" | 17 11/16" | 14 11/16" | 21-3/8" |

Optional Equipment

BAYOSAH001, 002A, 25% Outside Air Damper (Replaces Filter/Coil Access Panel)

The drawings on this page are prepared by the manufacturer in order to provide detail regarding job layout only. These drawings are not intended to be used as a basis to construct, build or modify the items depicted in the drawings. The manufacturer is not responsible for the unauthorized use of these drawings and expressly disclaims any liability for damages resulting from such unauthorized use.

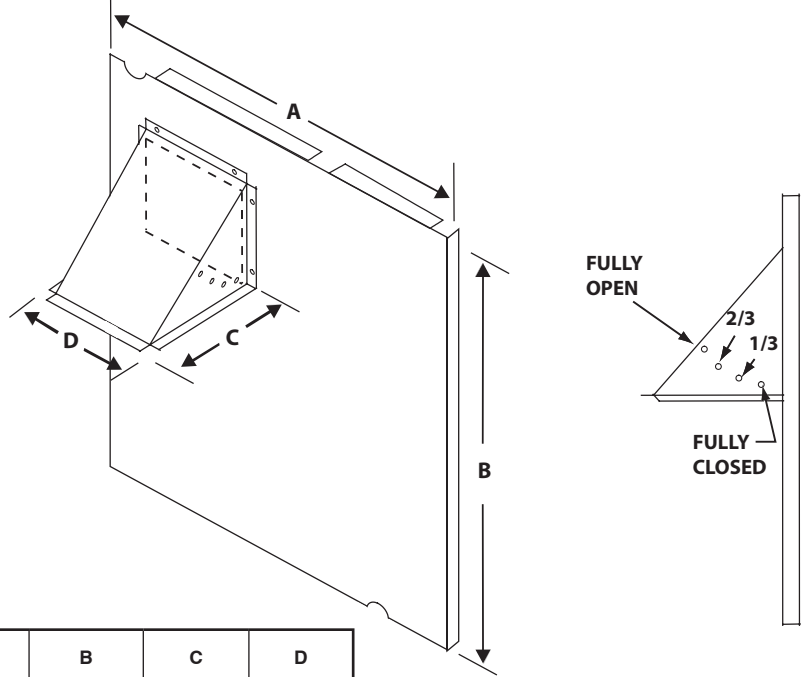

| Manual Fresh Air Model | Unit Application Models | A | B | C | D |
|------------------------|--|----------|-----------|---------|---------|
| BAYOSAH001 | 4YC,WC3018-036 4TC*3018-036 4W/T/Y/DCY4024-036 4W/Y/DCZ6036 | 22 7/16" | 20 11/16" | 12 3/8" | 9 3/16" |
| BAYOSAH002 | 4YC,WC3042-060 4TC*3042-060 4W/T/Y/DCY4042-060 4W/Y/DCZ6048-060 | 25 3/16" | 20 11/16" | 12 3/8" | 9 3/16" |

BAYDMPR101,102A, 25% Motorized Outside Air Damper (Mounts Over Horizontal Air Opening)

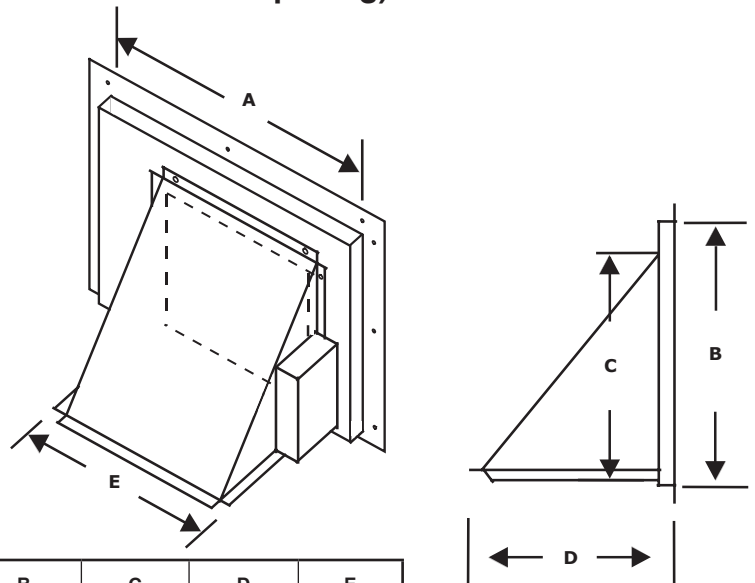

| | Unit Application Models | A | B | C | D | E |
|-------------|---|-----------|-----------|---------|---------|---------|
| BAYDMPR101A | 4YC,WC3018-036 4TC3018-036 4W/T/Y/DCY4024-036 4W/Y/DCZ6036 | 15 13/16" | 11 13/16" | 10 1/4" | 11 1/2" | 12 1/4" |
| BAYDMPR102A | 4YC,WC3042-060 4TC3042-060 4W/T/Y/DCY4042-060 4W/Y/DCZ6048-060 | 18 3/16" | 15 1/8" | 10 1/4" | 11 1/2" | 12 1/4" |

Dimensional Data

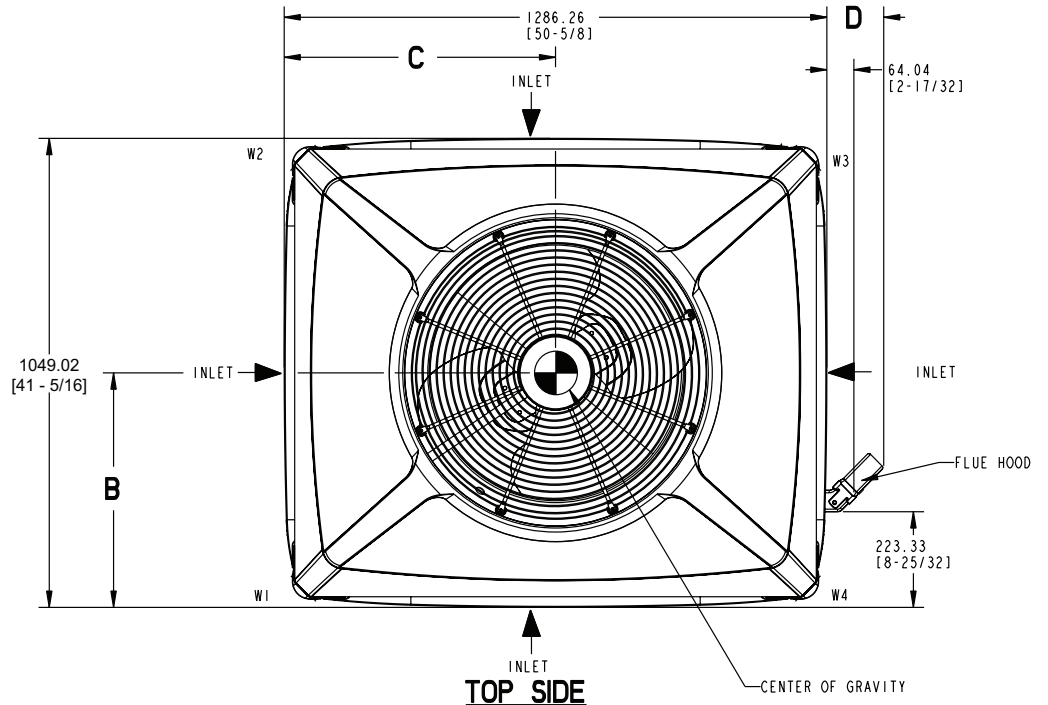

INLET
TOP SIDE
OUTLET

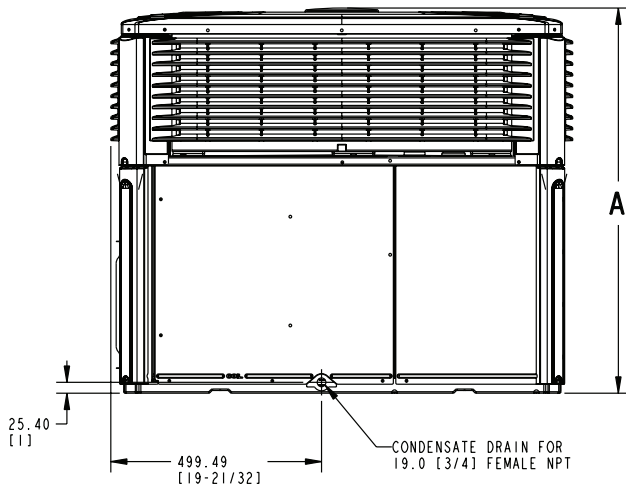

LEFT SIDE

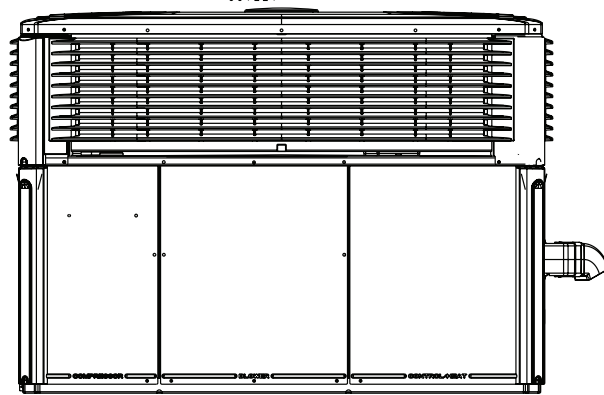

FRONT SIDE

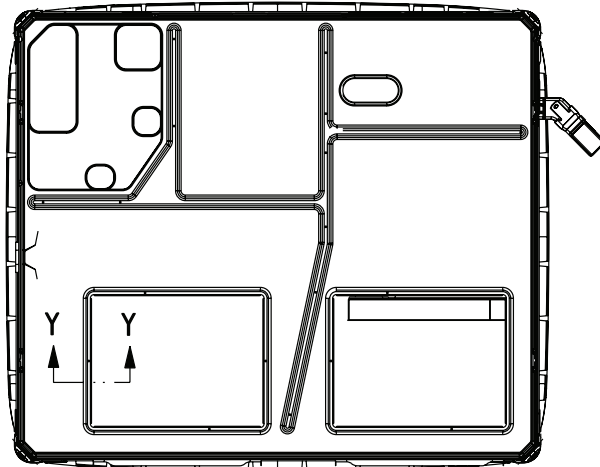
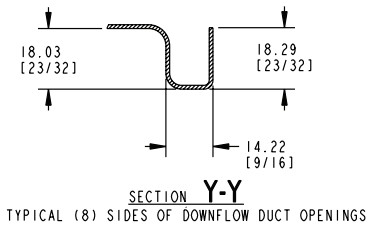

BOTTOM SIDE

4DCY4024 through 4DCY4036 (1 of 3)

Dimensional Data

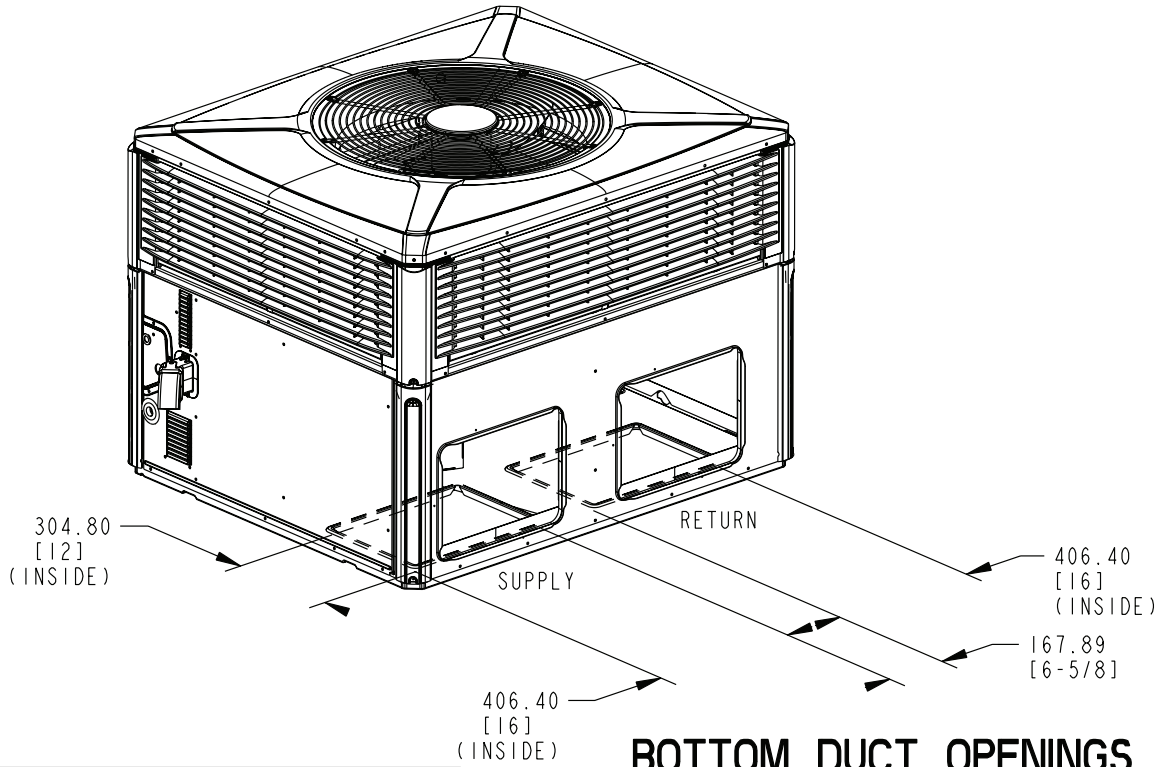

BOTTOM DUCT OPENINGS

| RECOMMENDED SERVICE CLEARANCE MM/IN. | | |
|--------------------------------------|-------------|-----------------|
| | | WITH ECONOMIZER |
| BACK SIDE | 304.8 [12] | 762.0 [30] |
| LEFT SIDE | 762.0 [30] | 914.4 [36] |
| RIGHT SIDE | 914.4 [36] | - |
| FRONT SIDE | 1066.8 [42] | - |

| CLEARANCE TO COMBUSTIBLE MATERIAL MM/IN. | |
|--|------------|
| BOTTOM | 0 |
| BACK SIDE | 25.4 [1] |
| LEFT SIDE | 152.4 [6] |
| RIGHT SIDE | 304.8 [12] |
| FRONT SIDE | 304.8 [12] |
| TOP | 914.4 [36] |

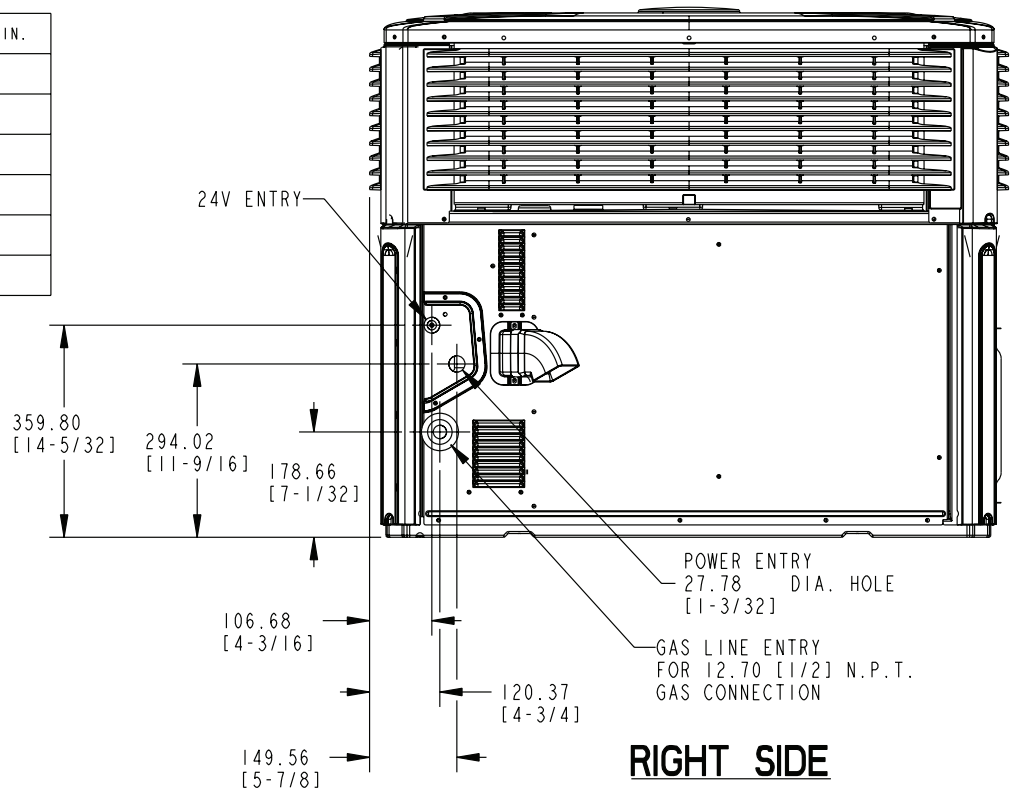

RIGHT SIDE

4DCY4024 through 4DCY4036 (2 of 3)

Dimensional Data

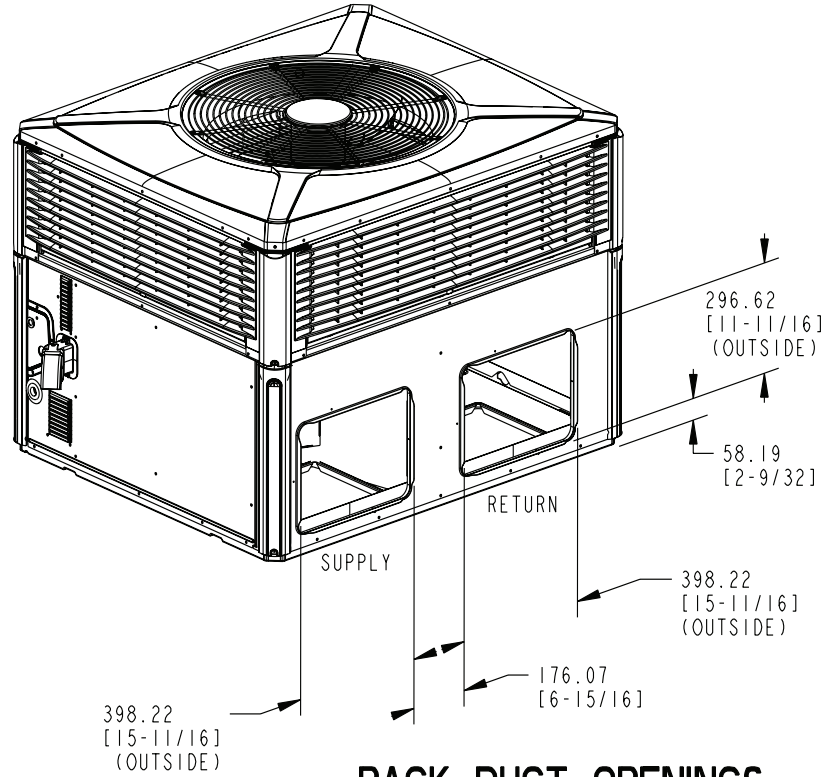

BACK DUCT OPENINGS

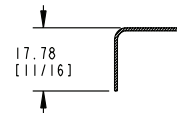
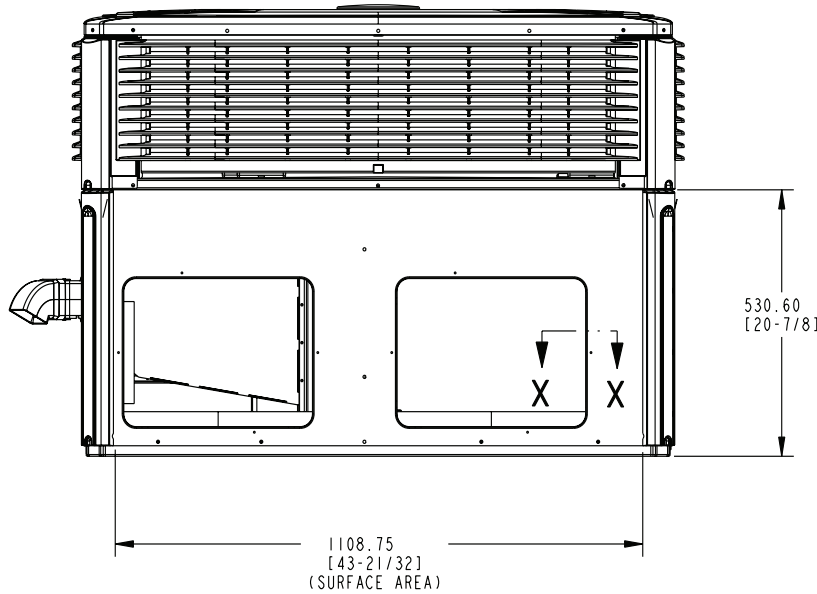

SECTION **X-X**
TYPICAL (8) SIDES OF SIDEFLOW DUCT OPENINGS

BACK SIDE

| MODEL | HEIGHT MM/IN. | FLUE HOOD W/BRKT MM/IN. | APPROX. CORNER WEIGHT - KG/LBS | | | | SHIPPING WEIGHT KG/LBS | TOTAL UNIT WEIGHT KG/LBS | CENTER OF GRAVITY MM/IN. | |
|------------------------|------------------|----------------------------|--------------------------------|-----------|-----------|------------|------------------------------|--------------------------------|--------------------------|--------------|
| | A | | D | W1 | W2 | W3 | | | W4 | B |
| 4CY4024 (060) | 903.29 [35-9/16] | - | 59.0 [130] | 37.2 [82] | 31.3 [69] | 48.5 [107] | 218.4 (481) | 174.8 [385] | 401.3 [15.8] | 546.1 [21.5] |
| 4CY4030 (070) | | | | | | | | | | |
| 4CY4036/4YCZ6036 (070) | 949.99 [37-3/8] | 117.86 [4-5/8] | 60.3 [133] | 36.3 [80] | 30.4 [67] | 50.3 [111] | 221.6 (488) | 178.0 [392] | 388.6 [15.3] | 558.8 [22.0] |
| 4CY4036/4YCZ6036 (090) | | | 61.2 [135] | 36.7 [81] | 30.8 [68] | 51.3 [113] | 223.8 (493) | 180.1 [397] | 388.6 [15.3] | 558.8 [22.0] |
| 4DCY4024 (060) | 903.29 [35-9/16] | - | 60.8 [134] | 38.1 [84] | 31.3 [69] | 48.5 [107] | 218.4 (481) | 174.8 [385] | 398.8 [15.7] | 546.1 [21.5] |
| 4DCY4030 (070) | | | | | | | | | | |
| 4DCY4036/4DCZ6036 | 949.99 [37-3/8] | 117.86 [4-5/8] | 62.1 [137] | 37.2 [82] | 30.4 [67] | 50.3 [111] | 221.6 (488) | 178.0 [392] | 386.1 [15.2] | 558.8 [22.0] |

4DCY4024 through 4DCY4036 (3 of 3)

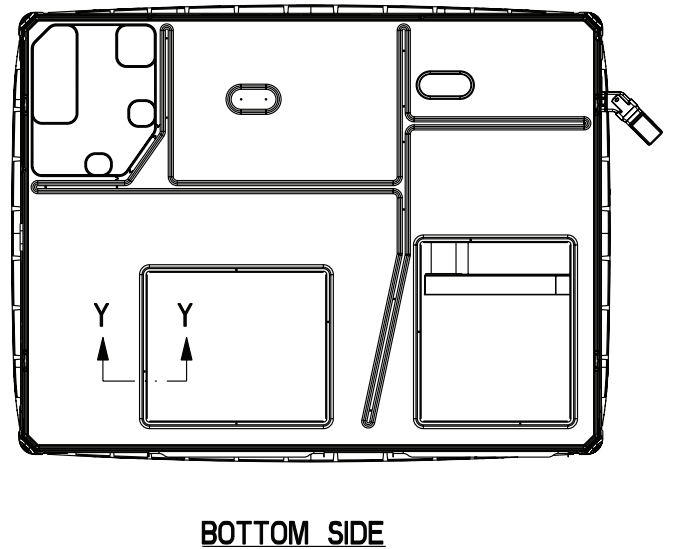
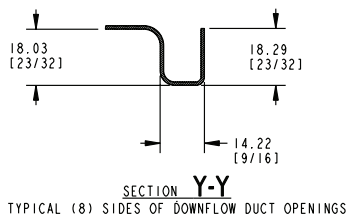
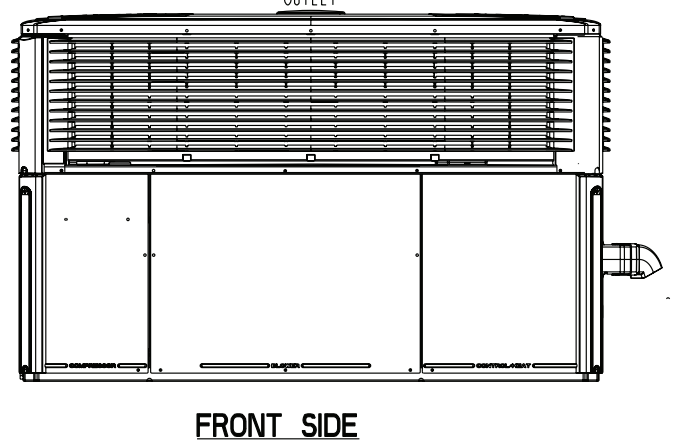
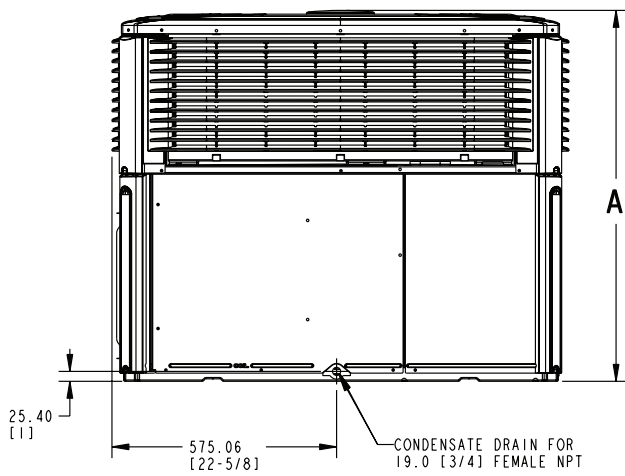
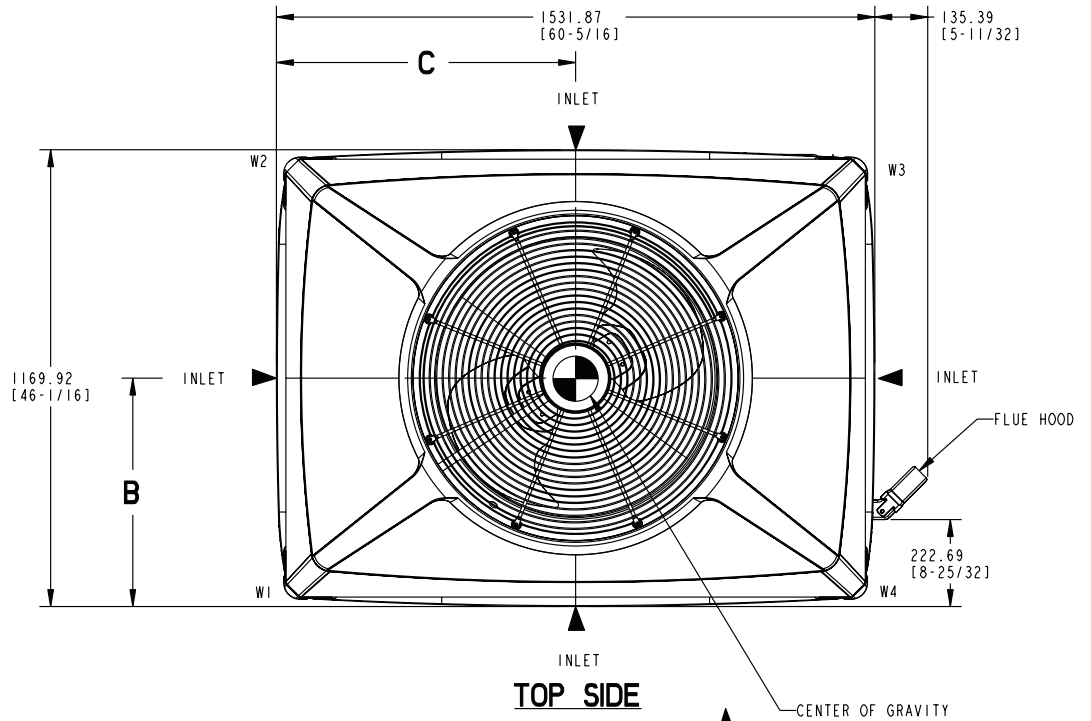

4DCY4042 through 4DCY4060 (1 of 3)

Dimensional Data

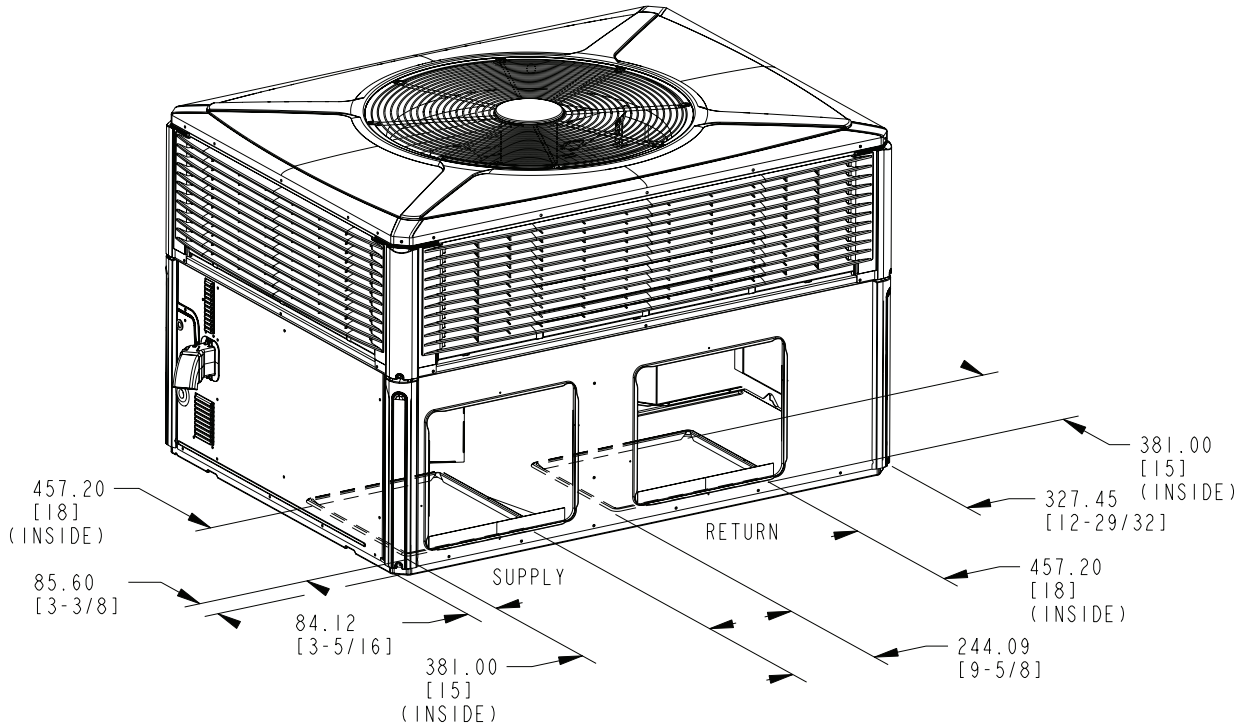

BOTTOM DUCT OPENINGS

| RECOMMENDED SERVICE CLEARANCE MM/IN. | | |
|--------------------------------------|-------------|------------------------|
| | | WITH O.A. DAMPER/ECON. |
| BACK SIDE | 304.8 [12] | 762.0 [30] |
| LEFT SIDE | 914.4 [36] | 1066.8 [42] |
| RIGHT SIDE | 914.4 [36] | - |
| FRONT SIDE | 1066.8 [42] | - |

| CLEARANCE TO COMBUSTIBLE MATERIAL MM/IN. | |
|--|------------|
| BOTTOM | 0 |
| BACK SIDE | 25.4 [1] |
| LEFT SIDE | 152.4 [6] |
| RIGHT SIDE | 304.8 [12] |
| FRONT SIDE | 304.8 [12] |
| TOP | 914.4 [36] |

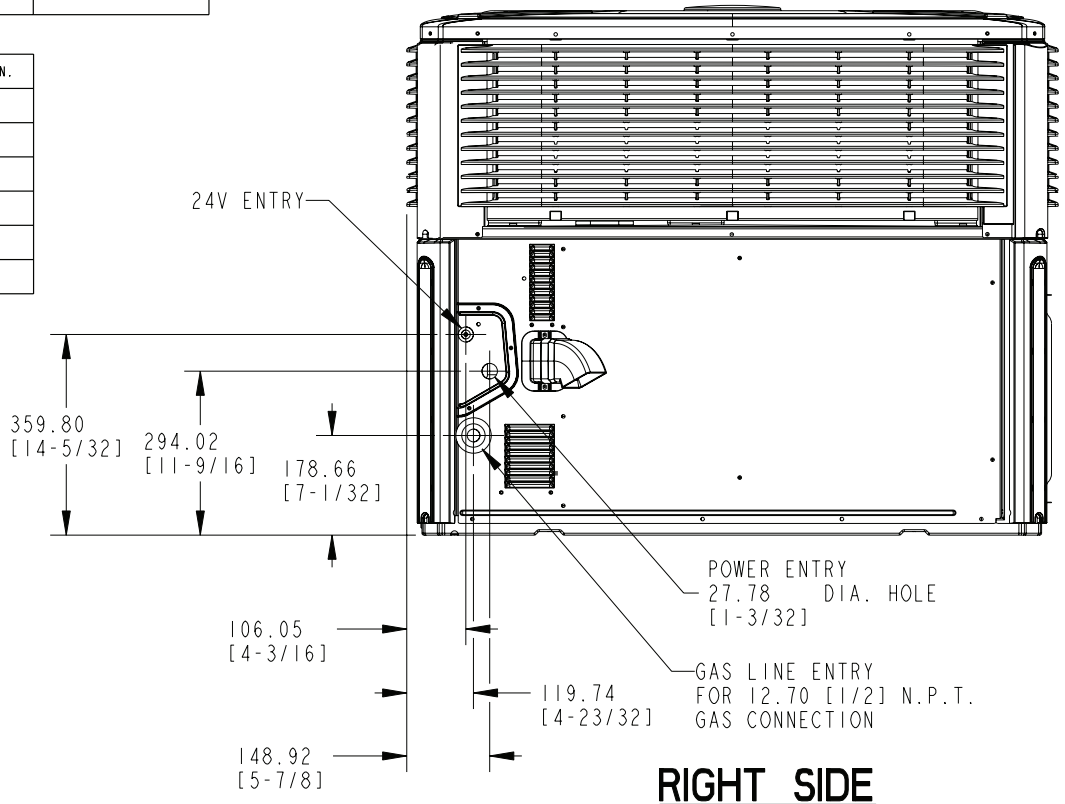

RIGHT SIDE

4DCY4042 through 4DCY4060 (2 of 3)

Dimensional Data

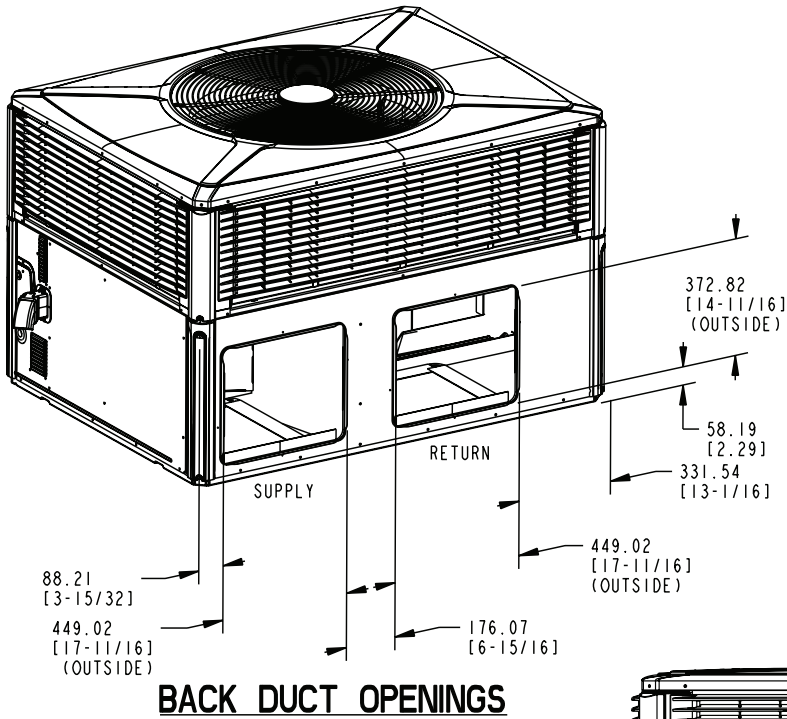

BACK DUCT OPENINGS

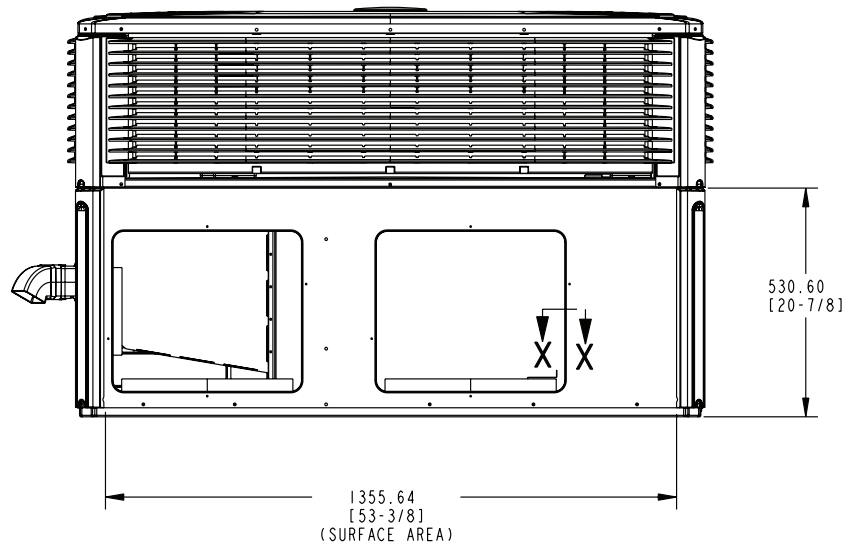
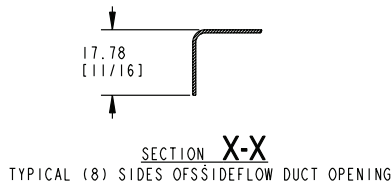

BACK SIDE

| MODEL | HEIGHT MM/IN. | APPROX. CORNER WEIGHT - KG/LBS | | | | SHIPPING WEIGHT KG/LBS | TOTAL UNIT WEIGHT KG/LBS | CENTER OF GRAVITY MM/IN. | |
|-----------------|------------------|--------------------------------|------------|------------|------------|------------------------|--------------------------|--------------------------|--------------|
| | A | W1 | W2 | W3 | W4 | | | B | C |
| 4CY4042C (090) | 949.33 [37-3/8] | 75.3 [166] | 50.3 [111] | 45.4 [100] | 67.6 [149] | 296.5 [653] | 238.1 [525] | 444.5 [17.5] | 698.5 [27.5] |
| 4CY4048C (090) | 949.33 [37-3/8] | 77.1 [170] | 52.2 [115] | 47.2 [104] | 69.4 [153] | 303.4 [669] | 245.9 [541] | 444.5 [17.5] | 698.5 [27.5] |
| 4CY4048C (115) | 949.33 [37-3/8] | 77.1 [170] | 52.2 [115] | 47.2 [104] | 69.4 [153] | 303.4 [669] | 245.9 [541] | 444.5 [17.5] | 698.5 [27.5] |
| 4CY4060C (115) | 1050.93 [41-3/8] | 82.1 [181] | 46.3 [102] | 43.1 [95] | 76.7 [169] | 306.9 [676] | 248.6 [548] | 401.3 [15.8] | 711.2 [28.0] |
| 4DCY4042C (090) | 949.33 [37-3/8] | 77.1 [170] | 51.3 [113] | 45.4 [100] | 67.6 [149] | 296.5 [653] | 238.4 [525] | 442.0 [17.4] | 698.5 [27.5] |
| 4DCY4048C (090) | 949.33 [37-3/8] | 78.9 [174] | 53.0 [117] | 47.2 [104] | 69.4 [153] | 306.6 [676] | 248.5 [548] | 442.0 [17.4] | 698.5 [27.5] |
| 4DCY4060C (115) | 1050.93 [41-3/8] | 83.9 [185] | 47.2 [104] | 43.1 [95] | 76.7 [169] | 306.9 [676] | 248.8 [548] | 398.8 [15.7] | 711.2 [28.0] |
| 4YCZ6048C (090) | 1050.93 [41-3/8] | 75.7 [167] | 50.8 [112] | 45.8 [101] | 68.5 [151] | 299.2 [659] | 240.9 [531] | 444.5 [17.5] | 698.5 [27.5] |
| 4YCZ6048C (115) | | 81.6 [180] | 46.3 [102] | 42.2 [93] | 73.5 [162] | 301.6 [665] | 243.6 [537] | 419.1 [16.5] | 706.1 [27.8] |
| 4YCZ6060C (115) | 1050.93 [41-3/8] | 82.1 [181] | 46.3 [102] | 43.1 [95] | 76.7 [169] | 306.9 [676] | 248.6 [548] | 401.3 [15.8] | 711.2 [28.0] |
| 4DCZ6048C (090) | 1050.93 [41-3/8] | 81.6 [180] | 46.3 [102] | 42.2 [93] | 73.5 [162] | 301.6 [665] | 243.6 [537] | 419.1 [16.5] | 706.1 [27.8] |
| 4DCZ6060C (115) | 1050.93 [41-3/8] | 83.9 [185] | 47.2 [104] | 43.1 [95] | 75.7 [169] | 306.9 [676] | 248.8 [548] | 398.8 [15.7] | 711.2 [28.0] |

4DCY4042 through 4DCY4060 (3 of 3)

Mechanical Specifications

General

All units shall be factory assembled, piped, internally wired and fully charged with refrigerant. All units shall be designed to operate at outdoor ambient temperatures as high as 115°F. Cooling capacities shall be rated in accordance with A.H.R.I. standards. The 4DCY4 heating/cooling unit design is certified to UL Standards 1995 and ANSI 221.47/CSA 2.3, specifically for outdoor applications using natural gas or propane. All units shall be designed for outdoor rooftop or ground level installation. Unit casing is constructed of heavy gauge, galvanized steel and painted with a weather-resistant powder paint.

Shipped for horizontal application, convertible to downflow.

Casings

All panels shall be heavy gauge steel, gasketed and insulated. Foil-faced insulation shall be in the heat exchanger section. Foil-faced insulation shall be in the evaporator section. Base pan shall be heavy gauge steel. **WEATHERGUARD™** exterior corrosion resistant screws shall be used for added resistance to rust and corrosion.

Controls

Refrigeration cycle controls shall include condenser fan, evaporator fan and compressor contactors. Compressors shall be equipped with a combination internal winding thermostat/current overload. Internal high pressure relief shall also be provided.

Refrigeration System

Compressors —

The **Duration™** compressor features internal over temperature and pressure protector, total dipped hermetic motor. Other features include: centrifugal oil pump, and low vibration and noise.

Evaporator Coil — Internally enhanced 3/8-inch OD seamless copper tubing mechanically bonded to aluminum fins, factory pressure and leak tested at 250 to 300 psig. All units have TXV to control refrigeration flow.

Condenser Coil —

The **Spine Fin™** condenser coil shall be continuously wrapped, corrosion resistant all aluminum with minimum brazed joints. This coil is 3/8 inch OD seamless aluminum tubing glued to a continuous aluminum fin. Coils are lab tested to withstand 2,000 pounds of pressure per square inch. The outdoor coil provides low airflow resistance and efficient heat transfer. The coil is protected on all four sides by louvered panels.

Indoor Air Fan — Direct-drive, forward-curved, centrifugal wheel in a Composite **Vortica®** Blower housing. Motor shall have thermal overload protection. Permanently lubricated motor bearings. Motor/blower assembly isolated from unit with rubber mounts.

Condenser Fan — Direct-drive, draw through propeller type. Weather-proofed permanent split capacitor fan motor shall have built-in thermal overload and permanently lubricated motor bearings.

Low Ambient — Standard refrigerant system operation down to 55°F. Low ambient accessory required for operation to 0°F ambient condition.

Gas-Fired Heating System — Models shall provide completely assembled, wired and piped gas fired heating systems within unit. Threaded gas connection on the unit.

Electronic Ignition System — Main burner is lit each time thermostat calls for gas heat. Flame sensor proves flame and keeps the main burners on. Should a loss of flame occur, the main valve closes and the spark recurs within 0.8 second. When thermostat is satisfied, main burner is extinguished.

Forced Combustion Blower — Insures flame stability under varying wind conditions. Gives higher combustion efficiency and location flexibility.

Heat Exchanger — stainless steel tubes. Free floating design.

Burners — Stainless steel. Multi-port inshot.

Accessories

(U.S. Domestic Models)

Roof Curb — The roof curb shall be designed to mate with the unit and provide support and complete weather-tight installation when properly installed. Curb shall ship knocked down for field assembly, and include wood nailer strips.

Modulating Economizer — This accessory shall be field installed and be composed of the following items: 0-100% fresh air damper, damper drive motor fixed dry bulb enthalpy control, and low voltage polarized plug for electrical connections. Solid state enthalpy or differential enthalpy control is optional. Economizer operations shall be controlled by the preset position of the enthalpy control. A barometric relief damper shall be standard with the economizer and provide a pressure operated damper that shall be gravity closing and prohibit entrance of outside air on equipment "off" cycle.

Manual Fresh Air Hood

Manual outside air provides a fixed outside air quantity from 0 to 25 percent. Includes hood and birdscreen.

Low Ambient Control

Control allows cycling of compressor under low ambient cooling conditions. Required for cooling operation to 0°F.

Propane Gas

Conversion Kit — For conversion from natural gas to LP gas.

About Trane and American Standard Heating and Air Conditioning

Trane and American Standard create comfortable, energy efficient indoor environments for residential applications. For more information, please visit www.trane.com or www.americanstandardair.com

The manufacturer has a policy of continuous data improvement and it reserves the right to change design and specifications without notice. We are committed to using environmentally conscious print practices.



The AHRI Certified mark indicates company participation in the AHRI Certification program. For verification of individual certified products, go to ahridirectory.org.