

# Installer's Guide

## American Standard Link or AccuLink™ Variable Speed Heat Pumps and Air Conditioners

4A6V8X24A1000A  
4A6V8X36A1000A  
4A6V8X48A1000A  
4A6V8X60A1000A

4A7V8X24A1000A  
4A7V8X36A1000A  
4A7V8X48A1000A  
4A7V8X60A1000A

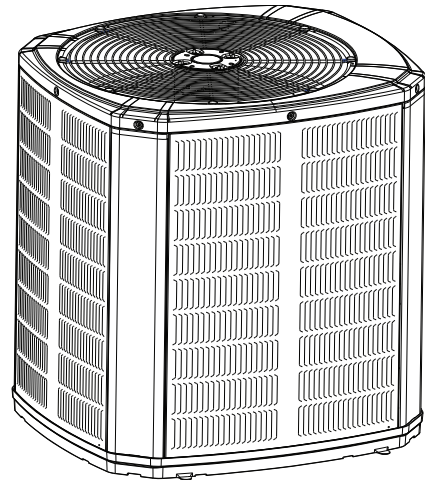

The *Diagnostics Mobile App* is available by scanning a QR code located inside this unit or by searching for the *Link Diagnostics App* in your *App Store*®.

**Note:** "Graphics in this document are for representation only. Actual model may differ in appearance."

**Note:** This unit can be used in *AccuLink™* mode or *American Standard Link* mode.

### ⚠ SAFETY WARNING

Only qualified personnel should install and service the equipment. The installation, starting up, and servicing of heating, ventilating, and air-conditioning equipment can be hazardous and requires specific knowledge and training. Improperly installed, adjusted or altered equipment by an unqualified person could result in death or serious injury. When working on the equipment, observe all precautions in the literature and on the tags, stickers, and labels that are attached to the equipment.

## SAFETY SECTION

**Important** — This document contains a wiring diagram and service information. This is customer property and is to remain with this unit. Please return to service information pack upon completion of work.

### **⚠ WARNING**

#### **HAZARDOUS VOLTAGE!**

Failure to follow this Warning could result in property damage, severe personal injury, or death.

Disconnect all electric power, including remote disconnects before servicing. Follow proper lockout/tagout procedures to ensure the power cannot be inadvertently energized.

### **⚠ WARNING**

#### **REFRIGERANT OIL!**

Any attempt to repair a central air conditioning product may result in property damage, severe personal injury, or death.

These units use R-410A refrigerant which operates at 50 to 70% higher pressures than R-22. Use only R-410A approved service equipment. Refrigerant cylinders are painted a "Rose" color to indicate the type of refrigerant and may contain a "dip" tube to allow for charging of liquid refrigerant into the system. All R-410A systems with variable speed compressors use a PVE oil that readily absorbs moisture from the atmosphere. To limit this "hygroscopic" action, the system should remain sealed whenever possible. If a system has been open to the atmosphere for more than 4 hours, the compressor oil must be replaced. Never break a vacuum with air and always change the driers when opening the system for component replacement.

### **⚠ CAUTION**

#### **HOT SURFACE!**

May cause minor to severe burning. Failure to follow this Caution could result in property damage or personal injury.

Do not touch top of compressor.

### **⚠ CAUTION**

#### **CONTAINS REFRIGERANT!**

Failure to follow proper procedures can result in personal illness or injury or severe equipment damage.

System contains oil and refrigerant under high pressure. Recover refrigerant to relieve pressure before opening system.

### **⚠ CAUTION**

#### **GROUNDING REQUIRED!**

Failure to inspect or use proper service tools may result in equipment damage or personal injury.

Reconnect all grounding devices. All parts of this product that are capable of conducting electrical current are grounded. If grounding wires, screws, straps, clips, nuts, or washers used to complete a path to ground are removed for service, they must be returned to their original position and properly fastened.

### **⚠ WARNING**

#### **SERVICE VALVES!**

Failure to follow this warning will result in abrupt release of system charge and may result in personal injury and/or property damage.

Extreme caution should be exercised when opening the Suction and Liquid Line Service Valve. Turn valve stem counterclockwise only until the stem contacts the rolled edge. No torque is required.

### **⚠ WARNING**

#### **BRAZING REQUIRED — IF USING MECHANICAL CONNECTIONS, ENSURE LEAK TEST IS NEGATIVE!**

Failure to inspect lines or use proper service tools may result in equipment damage or personal injury.

If using existing refrigerant lines make certain that all joints are brazed, not soldered.

### **⚠ WARNING**

#### **HIGH LEAKAGE CURRENT!**

Failure to follow this Warning could result in property damage, severe personal injury, or death.

Earth connection essential before connecting electrical supply.

⚠
WARNING

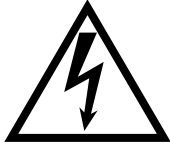

400 VOLTS  
ELECTRICAL HAZARD

Failure to follow this warning could result in personal injury or death.

WAIT TWO (2) MINUTES after disconnecting power prior to touching electrical components as they may hold a dangerous charge of 400VDC, then verify DC Voltage is less than 42 VDC at inverter test points labeled +VDC and -VDC before servicing board.



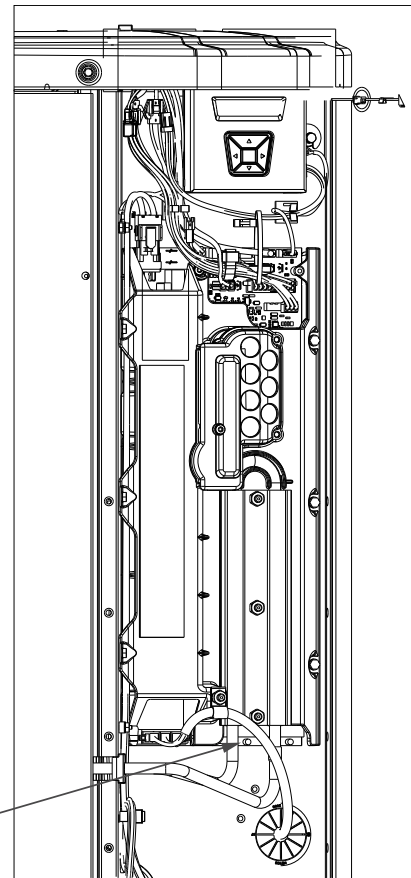

+VDC and  
-VDC

**Approved Combinations for Variable Speed Units running in American Standard Link mode**

- UX360 Smart Thermostat
- SC360 System Controller
- Approved System Accessories
- TAMX
- S8V2xxxxxVC

**Approved Combinations for Variable Speed Units running in AccuLink mode**

- ACONT850, AZONE950 or AZON1050
- TAM9
- TAM8C
- TAM8
- S9V2 Furnace w/Relay Panel
- Platinum 95 Furnace
- Platinum 80 Furnace
- Approved System Accessories

**Note:** See AHRI directory for approved indoor and outdoor model combinations. Only Trane / American Standard coils and air handlers are approved for use with variable speed outdoor unit.

**Important:** Use caution when cleaning outdoor coil to ensure no water enters the electrical control compartment. When cleaning coil from inside the compressor compartment, take special care not to spray water towards the top rows of the coil near the control panel. Water may enter the control compartment and drive damaging the electronics. Disconnect all electric power, including remote disconnects before servicing.

**Table 1. Operating Range**

Cooling	55° F to 120° F
Heating	-10° F to 66° F

## Table of Contents

Unit Location Considerations.....	5	Integrated Variable Speed Control Board LED Indicators.....	20
.....	6	Start Up .....	21
Coastal Considerations.....	7	System Charge Adjustment .....	22
Unit Preparation.....	8	Subcool Charging Correction	
Setting Up the Unit .....	8	Charts .....	23
Refrigerant Line Considerations .....	9	Refrigerant Charging Chart .....	24
Refrigerant Line Brazing .....	12	Charging the Unit.....	25
Refrigerant Line Leak Check .....	14	Subcooling Charging Below 55° F	
Refrigerant Line and Indoor Coil		Outdoor Temp. (In Heating Only) .....	26
Evacuation.....	14	Communicating Display Assembly	
Service Valves.....	15	(CANda) .....	27
Electrical – Low Voltage		Defrost Control (Heat Pump only).....	28
Communicating .....	16	Checkout Procedures .....	29
Electrical – High Voltage.....	19		

# Unit Location Considerations

**Table 2. Unit Dimensions and Weight**

Models	H x D x W (in)	Weight * (lb)
4A6V8X24A	41 x 30 x 33	195
4A6V8X36A	41 x 30 x 33	208
4A6V8X48A	41 x 34 x 37	234
4A6V8X60A	45 x 34 x 37	250
4A7V8X24A	41 x 30 x 33	196
4A7V8X36A	41 x 30 x 33	207
4A7V8X48A	41 x 34 x 37	245
4A7V8X60A	45 x 34 x 37	250

\* Weight values are estimated (uncrated).

- When mounting the outdoor unit on a roof, be sure the roof will support the unit's weight.
- Properly selected isolation is recommended to alleviate sound or vibration transmission to the building structure.

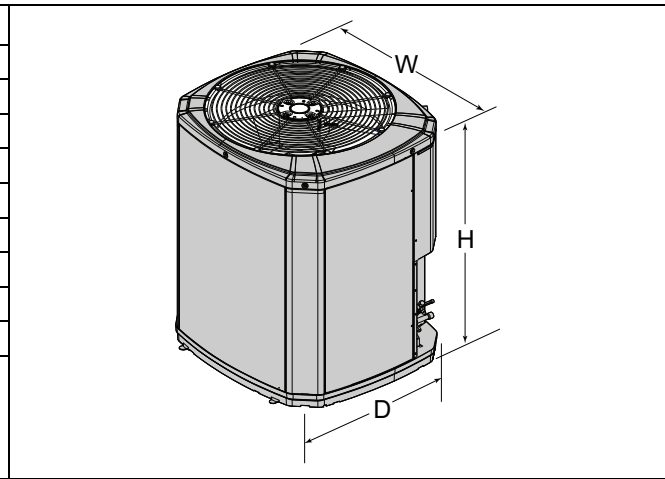

**Table 3. Refrigerant Line and Service Valve Connection Sizes**

Model	Rated Line Sizes		Service Valve Connection Sizes	
	Vapor Line	Liquid Line	Vapor Line Connection	Liquid Line Connection
4A6V8X24A	5/8 (a)	3/8	3/4	3/8
4A6V8X36A	3/4 (a)	3/8	3/4	3/8
4A6V8X48A	7/8 (a)	3/8	7/8	3/8
4A6V8X60A	7/8 (a)	3/8	7/8	3/8
4A7V8X24A	5/8 (a)	3/8	3/4	3/8
4A7V8X36A	3/4 (a)	3/8	3/4	3/8
4A7V8X48A	7/8 (a)	3/8	7/8	3/8
4A7V8X60A	1-1/8 (b)	3/8	7/8	3/8

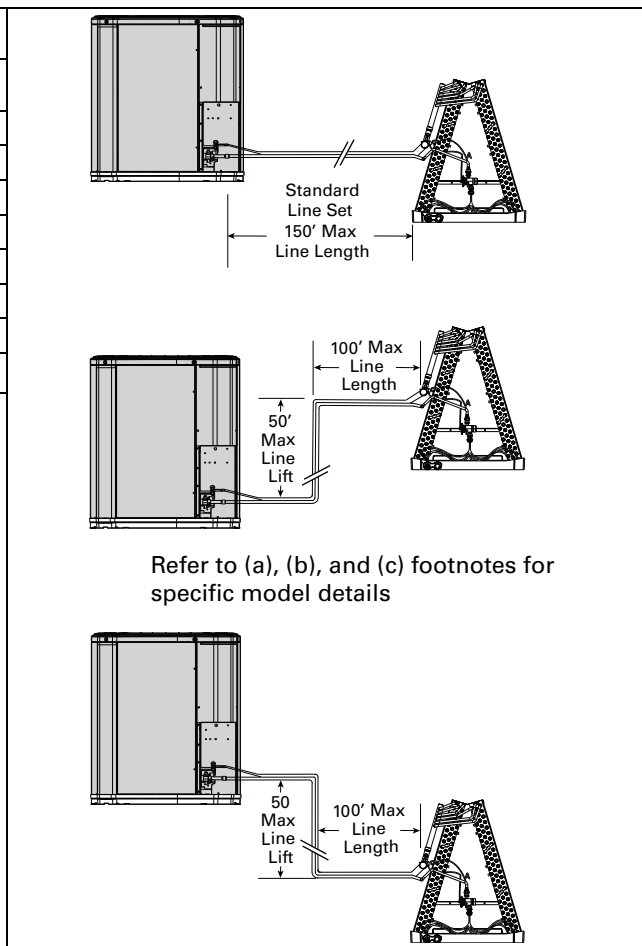

(a) The max length of refrigerant lines from outdoor to indoor unit MUST NOT exceed 150 feet. The max vertical change MUST NOT exceed 50 feet.  
 (b) The max length of refrigerant lines from outdoor to indoor unit MUST NOT exceed 80 feet. The max vertical change MUST NOT exceed 25 feet.

## Unit Location Considerations

**Table 4. Alternate Refrigerant Line and Service Valve Connection Sizes**

Model	Alternate Line Sizes		Service Valve Connection Sizes	
	Vapor Line	Liquid Line	Vapor Line Connection	Liquid Line Connection
4A6V8X24A	3/4" (a)	5/16"	3/4"	3/8"
4A6V8X36A	5/8" (a)	5/16"	3/4"	3/8"
4A6V8X48A	3/4" (a)	3/8"	7/8"	3/8"
4A6V8X60A	3/4" (a)	3/8"	7/8"	3/8"
	7/8" (a)	3/8"	7/8"	3/8"

Model	Alternate Line Sizes		Service Valve Connection Sizes	
	Vapor Line	Liquid Line	Vapor Line Connection	Liquid Line Connection
4A7V8X24A	3/4" (a)	5/16"	3/4"	3/8"
4A7V8X36A	5/8" (a)	5/16"	3/4"	3/8"
4A7V8X48A	3/4" (a)	3/8"	7/8"	3/8"
4A7V8X60A	3/4" (a)	3/8"	7/8"	3/8"
	7/8" (a)	3/8"	7/8"	3/8"

(a) The max length of refrigerant lines from outdoor to indoor unit MUST NOT exceed 150 feet. The max vertical change MUST NOT exceed 50 feet.

**Table 5. Suggested Locations for Best Reliability**

- Ensure the top discharge area is unrestricted for at least 5 feet above the unit.
- Provide at least 3 feet clearance in front of the control box (access panels) and any other side requiring service.
- Do not locate close to bedrooms as operational sounds may be objectionable.
- Avoid locations near windows and similar areas where condensation and freezing defrost vapor can annoy a customer.
- Position the outdoor unit a minimum of 12" from any wall or surrounding shrubbery to ensure adequate airflow.
- Outdoor unit location must be far enough away from any structure to prevent excess roof runoff water or icicles from falling directly on the unit.

- Position the outdoor unit a minimum of 12" from any wall or surrounding shrubbery to ensure adequate airflow.
- Outdoor unit location must be far enough away from any structure to prevent excess roof runoff water or icicles from falling directly on the unit.

The diagram illustrates the required clearances for the outdoor unit. A vertical dashed line indicates a minimum 5-foot unrestricted space above the unit. A horizontal dashed line indicates a minimum 3-foot unrestricted space in front of the unit, specifically around the access panel. Two vertical dashed lines on either side indicate a minimum 12-inch clearance from shrubbery. A circular icon with a diagonal line through it and the text 'Avoid Install Near Bedrooms' is shown near a window.

This diagram shows the unit's placement relative to a wall and shrubbery. A vertical dashed line on the left indicates a minimum 12-inch clearance from shrubbery. A vertical dashed line on the right indicates a minimum 12-inch clearance from the wall. A circular icon with a diagonal line through it and raindrops is shown above the unit, indicating that roof runoff water or icicles should not fall directly on the unit.

## Unit Location Considerations

**Table 6. Cold Climate Considerations (Heat Pump Only)**

<p><b>Note:</b> It is recommended that these precautions be taken for units being installed in areas where snow accumulation and prolonged below-freezing temperatures occur.</p> <ul style="list-style-type: none"> <li>Units should be elevated 3–12 inches above the pad or rooftop, depending on local weather. This additional height will allow drainage of snow and ice melted during defrost cycle prior to its refreezing. Ensure that drain holes in unit base pan are not obstructed, preventing drainage of defrost water.</li> <li>If possible, avoid locations that are likely to accumulate snow drifts. If not possible, a snow drift barrier should be installed around the unit to prevent a build-up of snow on the sides of the unit.</li> </ul>	 <p>The diagram shows a cross-section of a heat pump unit installed on a pad. The unit is supported by snow legs, providing a 3-12 inch elevation above the pad. To the left of the unit, a snow barrier is shown with a minimum height of 12 inches. Snowflakes are depicted falling around the unit, indicating a cold climate environment.</p>
--	---

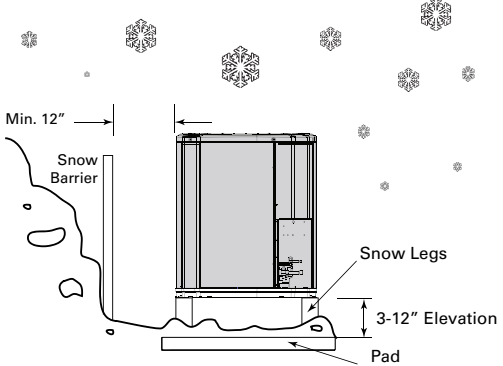
## Coastal Considerations

<p>If installed within one mile of salt water, including seacoasts and inland waterways, models without factory supplied Seacoast Salt Shields require the addition of BAYSEAC001 (Seacoast Kit) at installation time.</p>
--

## Unit Preparation

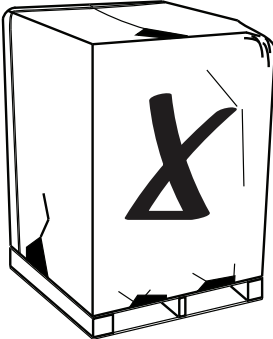
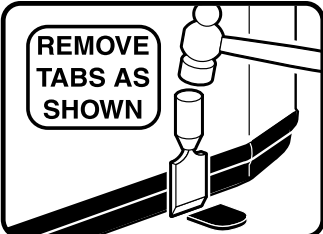
<p>1. Check for damage and report promptly to the carrier any damage found to the unit.</p>	
<p>2. To remove the unit from the pallet, remove tabs by cutting with a sharp tool.</p>	

## Setting Up the Unit

**Table 7. Pad Installation**

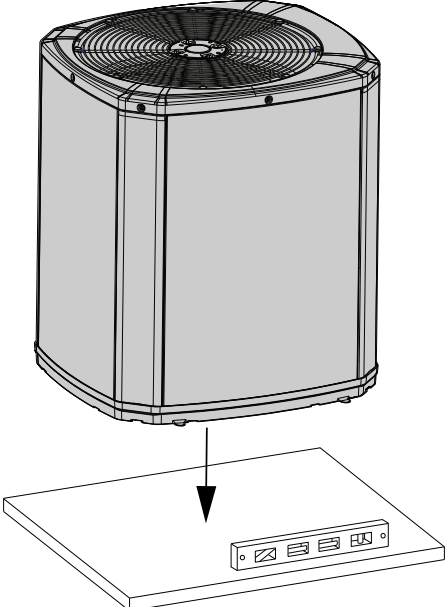
<p>When installing the unit on a support pad, such as a concrete slab, consider the following:</p> <ul style="list-style-type: none"><li>• The pad should be at least 1" larger than the unit on all sides.</li><li>• The pad must be separate from any structure.</li><li>• The pad must be level.</li><li>• The pad should be high enough above grade to allow for drainage.</li><li>• The pad location must comply with National, State, and Local codes.</li></ul>	
--	--



# Refrigerant Line Considerations

**Table 8. Factory Charge**

The outdoor condensing units are factory charged with the system charge required for the outdoor condensing unit, ten (10) feet of tested connecting line, and the smallest rated indoor evaporative coil match. Always verify proper system charge via subcooling (TXV/EEV).

**Table 9. Required Refrigerant Line Length**

Determine required line length and lift. You will need this to determine the subcooling charging corrections later in the installation process.

Total Line Length = \_\_\_\_\_ Ft.

Total Vertical Change (lift) = \_\_\_\_\_ Ft.

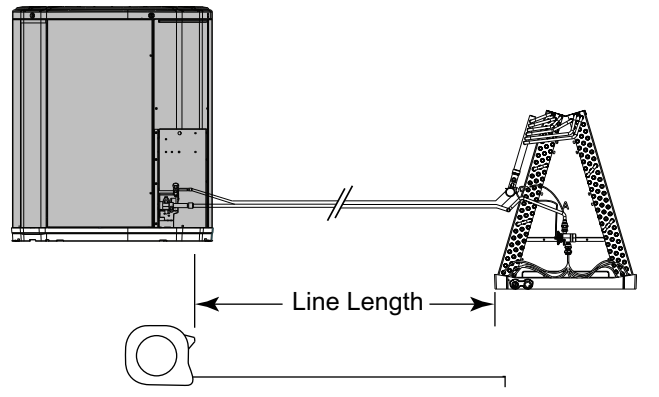

**Table 10. Refrigerant Line Insulation**

**Important:** The Vapor Line must always be insulated. DO NOT allow the Liquid Line and Vapor Line to come in direct (metal to metal) contact.

**Note:** The gas line must always be insulated. Insulating the liquid line through attic spaces may benefit system performance by minimizing heat gain in the liquid line.

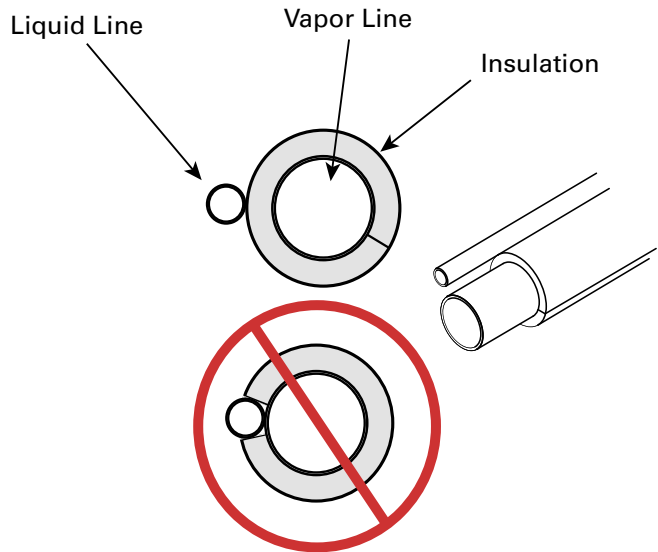

## Refrigerant Line Considerations

**Table 11. Reuse Existing Refrigerant Lines**

<div style="background-color: black; color: white; padding: 5px; text-align: center;"><b>⚠ CAUTION</b></div> <div style="border: 1px solid black; padding: 5px;"><b>REFRIGERANT!</b></div> <p>Failure to inspect or use proper service tools may result in equipment damage or personal injury. If using existing refrigerant lines make certain that all joints are brazed, not soldered.</p> <p>For retrofit applications, where the existing indoor evaporator coil and/or refrigerant lines will be used, the following precautions should be taken.</p> <ul style="list-style-type: none"> <li>• Ensure that the indoor evaporator coil and refrigerant lines are the correct size.</li> <li>• Ensure that the refrigerant lines are free of leaks, acid, and oil.</li> </ul> <p><b>Important:</b> For more information, see publication number SS-APG006-EN</p>	
---	--

**Table 12. Refrigerant Line Routing Precautions**

<p><b>Important:</b> Comply with National, State, and Local Codes when isolating line sets from joists, rafters, walls, or other structural elements.</p> <p><b>Important:</b> For buried linesets, see publication number SS-APG006-EN.</p> <p><b>Important:</b> Take precautions to prevent noise within the building structure due to vibration transmission from the refrigerant lines.</p> <p>For Example:</p> <ul style="list-style-type: none"> <li>• When the refrigerant lines must be fastened to floor joists or other framing in a structure, use isolation type hangers.</li> <li>• Isolation hangers should also be used when refrigerant lines are run in stud spaces or enclosed ceilings.</li> <li>• Where the refrigerant lines run through a wall or sill, they should be insulated and isolated.</li> <li>• Isolate the lines from all duct work.</li> <li>• Minimize the number of 90° turns.</li> </ul>
---

**Table 13. Isolation From Joist/Rafter**

	<p>Secure Vapor Line from joists using isolators every 8 ft. Secure Liquid Line directly to insulated Vapor Line using tape, wire, or other appropriate method every 8 ft.</p>
--	--

Refrigerant Line Considerations

Table 14. Isolation In Wall Spaces

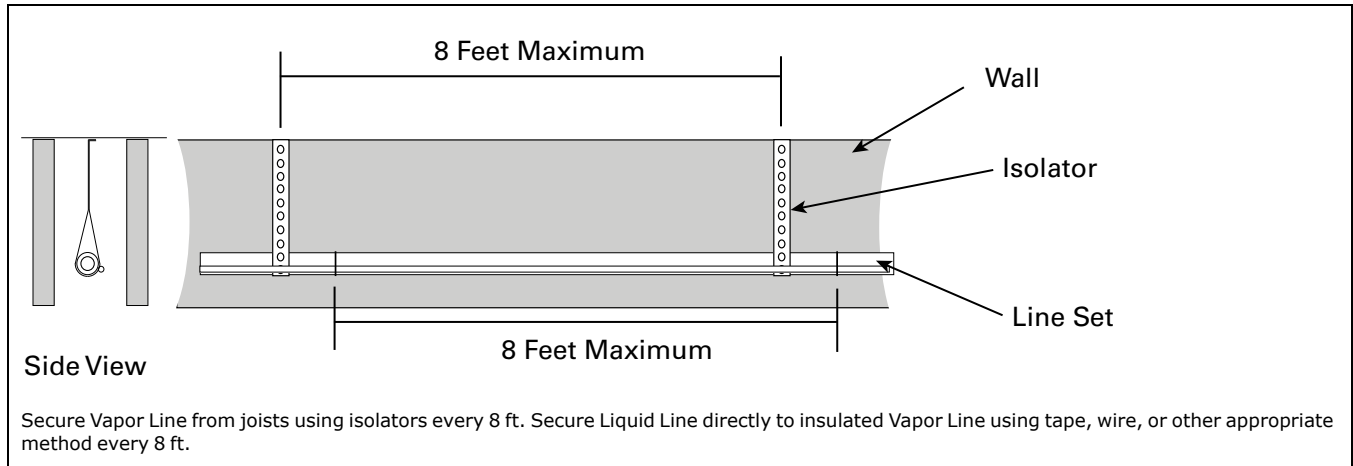
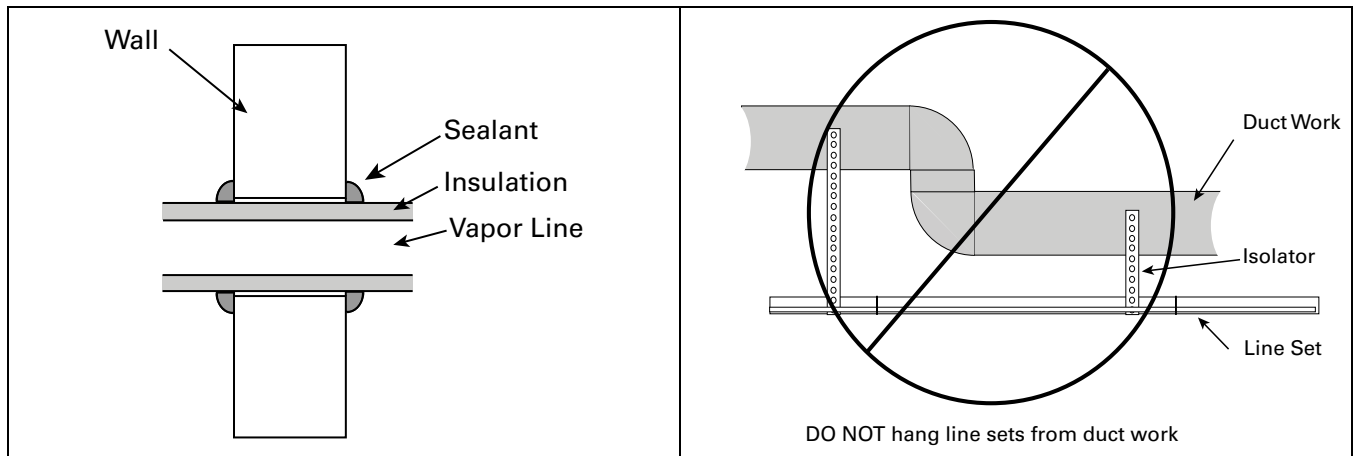
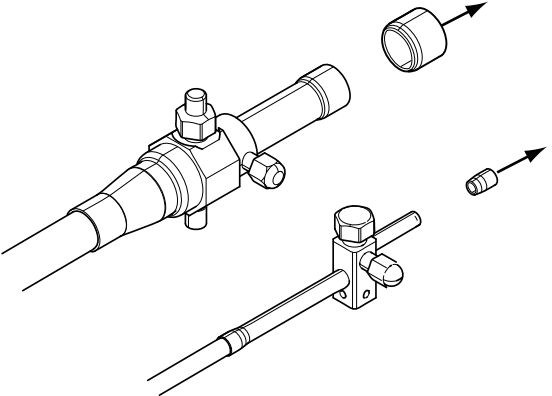
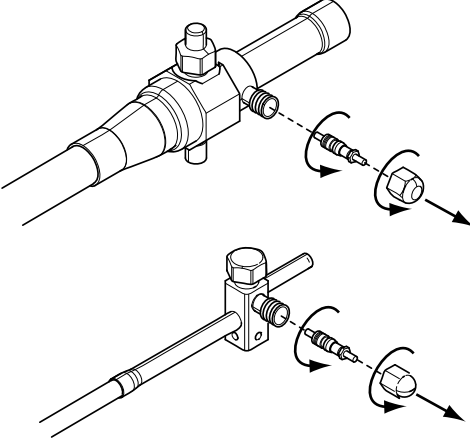
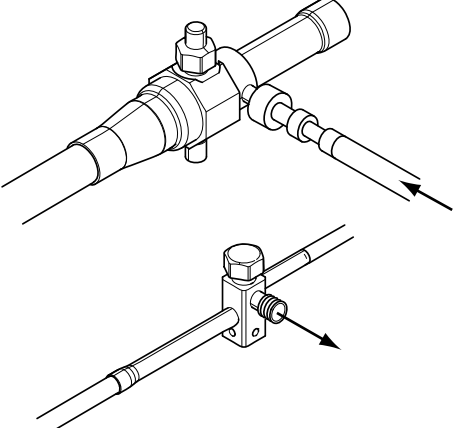

Table 15. Isolation Through Wall



## Refrigerant Line Brazing

**Table 16. Braze the Refrigerant Lines**

<p>1. Remove caps or plugs. Use a deburring tool to debur the pipe ends. Clean both internal and external surfaces of the tubing using an emery cloth.</p>	 <p>The diagram illustrates the first step of the brazing process. It shows two refrigerant lines connected to a central valve. On the left, a cap is being removed from the end of a pipe. On the right, a plug is being removed from a valve core. Arrows indicate the direction of removal. The pipes are shown with their ends being prepared for brazing.</p>
<p>2. Remove the pressure tap cap and valve core from each service valve.</p>	 <p>The diagram illustrates the second step of the brazing process. It shows the same two refrigerant lines and central valve. On the left, a pressure tap cap is being removed from the side of the pipe. On the right, a valve core is being removed from the valve. Arrows indicate the direction of removal. The pipes are shown with their ends being prepared for brazing.</p>
<p>3. Purge the refrigerant lines and indoor coil with dry nitrogen.</p>	 <p>The diagram illustrates the third step of the brazing process. It shows the same two refrigerant lines and central valve. Arrows indicate the flow of dry nitrogen gas through the pipes and the indoor coil, purging the system.</p>

## Refrigerant Line Brazing

**Table 16. Braze the Refrigerant Lines (continued)**

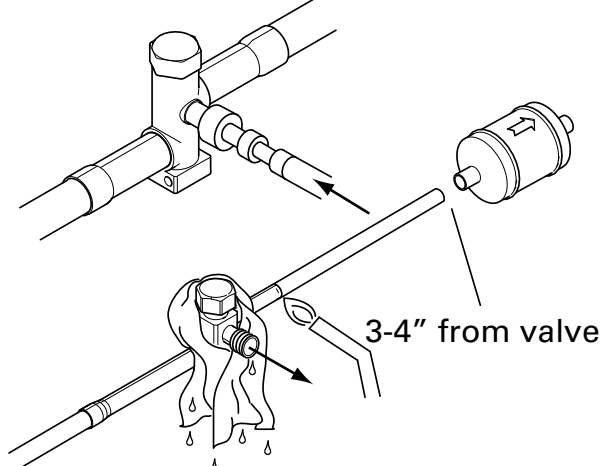
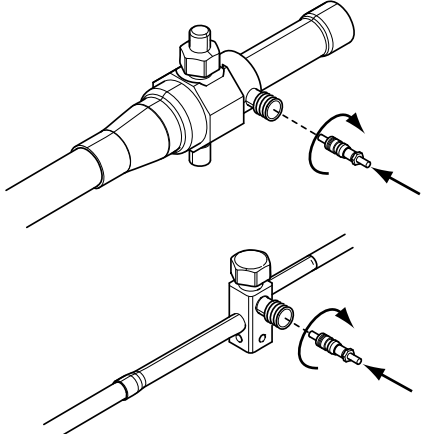

<p>4. Wrap a wet rag around the valve body to avoid heat damage and continue the dry nitrogen purge.</p> <p>5. Braze the refrigerant lines to the service valves.</p> <p>a. For Units shipped with a field-installed external drier, check liquid line filter drier's directional flow arrow to confirm correct direction of refrigeration flow (away from outdoor unit and toward evaporator coil) as illustrated. Braze the filter drier to the Liquid Line.</p> <p>6. Continue the dry nitrogen purge. Do not remove the wet rag until all brazing is completed.</p> <p><b>Important:</b> Remove the wet rag before stopping the dry nitrogen purge.</p> <p><b>Note:</b> Precautions should be taken to avoid heat damage to base pan during brazing. It is recommended to keep the flame directly off of the base pan.</p>	 <p>3-4" from valve</p>
<p>7. Replace the pressure tap valve cores after the service valves have cooled.</p>	

## Refrigerant Line Leak Check

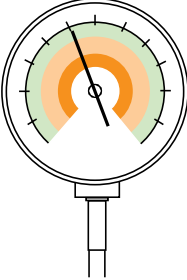
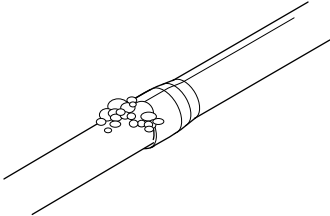
**Table 17. Check for Leaks**

<p>1. Pressurize the refrigerant lines and evaporator coil to 150 PSIG using dry nitrogen.</p>	<p>150 PSIG</p> 
<p>2. Check for leaks by using a soapy solution at each brazed location. <b>Note:</b> Remove nitrogen pressure and repair any leaks before continuing.</p>	

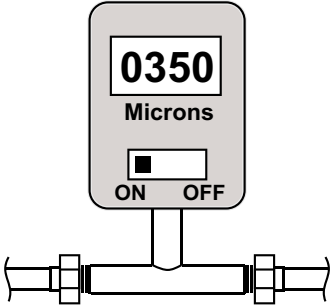
## Refrigerant Line and Indoor Coil Evacuation

<p><b>Important:</b> Do not open the service valves until the refrigerant lines and indoor coil leak check and evacuation are complete.</p> <p>1. Evacuate until the micron gauge reads no higher than 350 microns, then close off the valve to the vacuum pump.</p>	
<p>2. Observe the micron gauge. Evacuation is complete if the micron gauge does not rise above 500 microns in one (1) minute.</p> <p>3. When evacuation is complete, blank off the vacuum pump and micron gauge, and close the valves on the manifold gauge set.</p>	

# Service Valves

**Table 18. Open the Gas Service Valve**

<p><b>Important:</b> Leak check and evacuation must be completed before opening the service valves.</p> <p><b>Note:</b> Do not vent refrigerant gases into the atmosphere.</p> <ol style="list-style-type: none"> <li>1. Remove valve stem cap.</li> <li>2. Using a wrench, turn valve stem 1/4 turn counterclockwise to the fully open position.</li> <li>3. Replace the valve stem cap to prevent leaks. Tighten finger tight plus an additional 1/4 turn.</li> </ol>	<p>The diagram shows a gas service valve with a cap being removed from the valve stem. A curved arrow indicates a 1/4 turn counterclockwise rotation. Labels include: Cap, 1/4 Turn Only Counterclockwise for Full Open Position, Valve Stem, Unit Side of Valve, Pressure Tap Port, and Gas Line Connection.</p>
---	---

**Table 19. Open the Liquid Service Valve**

<div style="background-color: black; color: white; text-align: center; padding: 5px;"><b>⚠ WARNING</b></div> <p><b>SERVICE VALVES!</b></p> <p>Failure to follow this warning will result in abrupt release of system charge and may result in personal injury and/or property damage. Extreme caution should be exercised when opening the Suction and Liquid Line Service Valve. Turn valve stem counterclockwise only until the stem contacts the rolled edge. No torque is required.</p> <p><b>Important:</b> Leak check and evacuation must be completed before opening the service valves.</p> <ol style="list-style-type: none"> <li>4. Remove service valve cap.</li> <li>5. Fully insert 3/16" hex wrench into the stem and back out counterclockwise until valve stem just touches the rolled edge (approximately five (5) turns).</li> <li>6. Replace the valve cap to prevent leaks. Tighten finger tight plus an additional 1/4 turn.</li> </ol>	<p>The diagram shows a liquid service valve with a cap being removed. A 3/16" hex wrench is inserted into the stem, and a curved arrow indicates a counterclockwise rotation until it reaches a rolled edge. Labels include: Cap, Unit Side of Service Valve, 3/16" Hex Wrench, Rolled Edge to Captivate Stem, Hex Headed Valve System, and Service Port.</p>
--	---

# Electrical – Low Voltage Communicating

**Table 20. Low Voltage Maximum Wire Length**

<p>Table 20, p. 16 defines the size and combined total maximum length of low voltage wiring from the outdoor unit, to the indoor unit, and to the thermostat.</p> <p><b>Note:</b> The use of color coded low voltage wire is recommended to simplify connections between the outdoor unit, the control, and the indoor unit.</p> <p><b>Note:</b> The maximum total cable length for the entire comfort control communicating system is 500 ft. 18 AWG.</p>	CONTROL WIRING	
	WIRE SIZE	MAX. WIRE LENGTH
	18 AWG	500 Ft. Combined

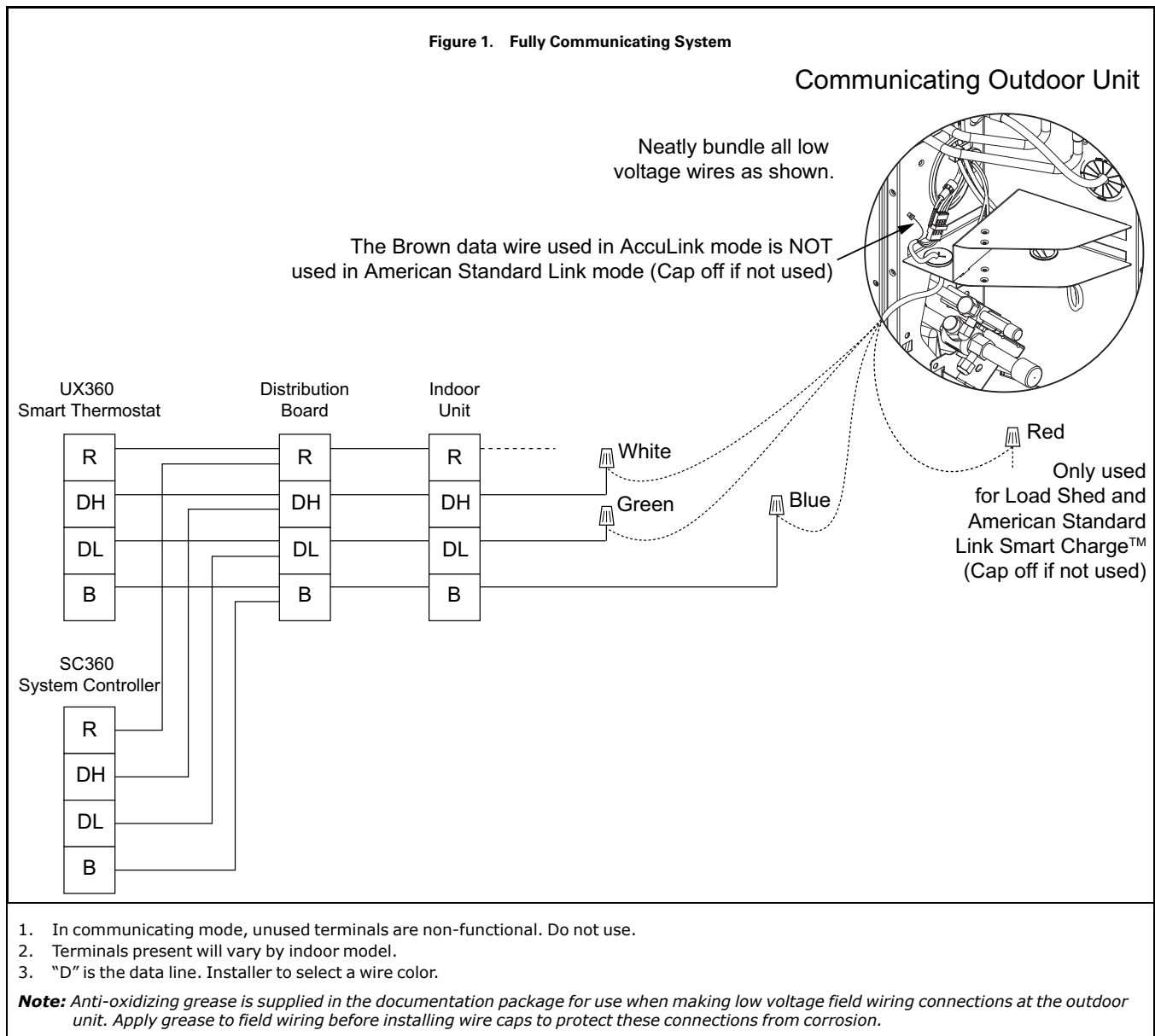



Electrical – Low Voltage Communicating

Table 21. Low Voltage Hook-up Diagrams in AccuLink mode

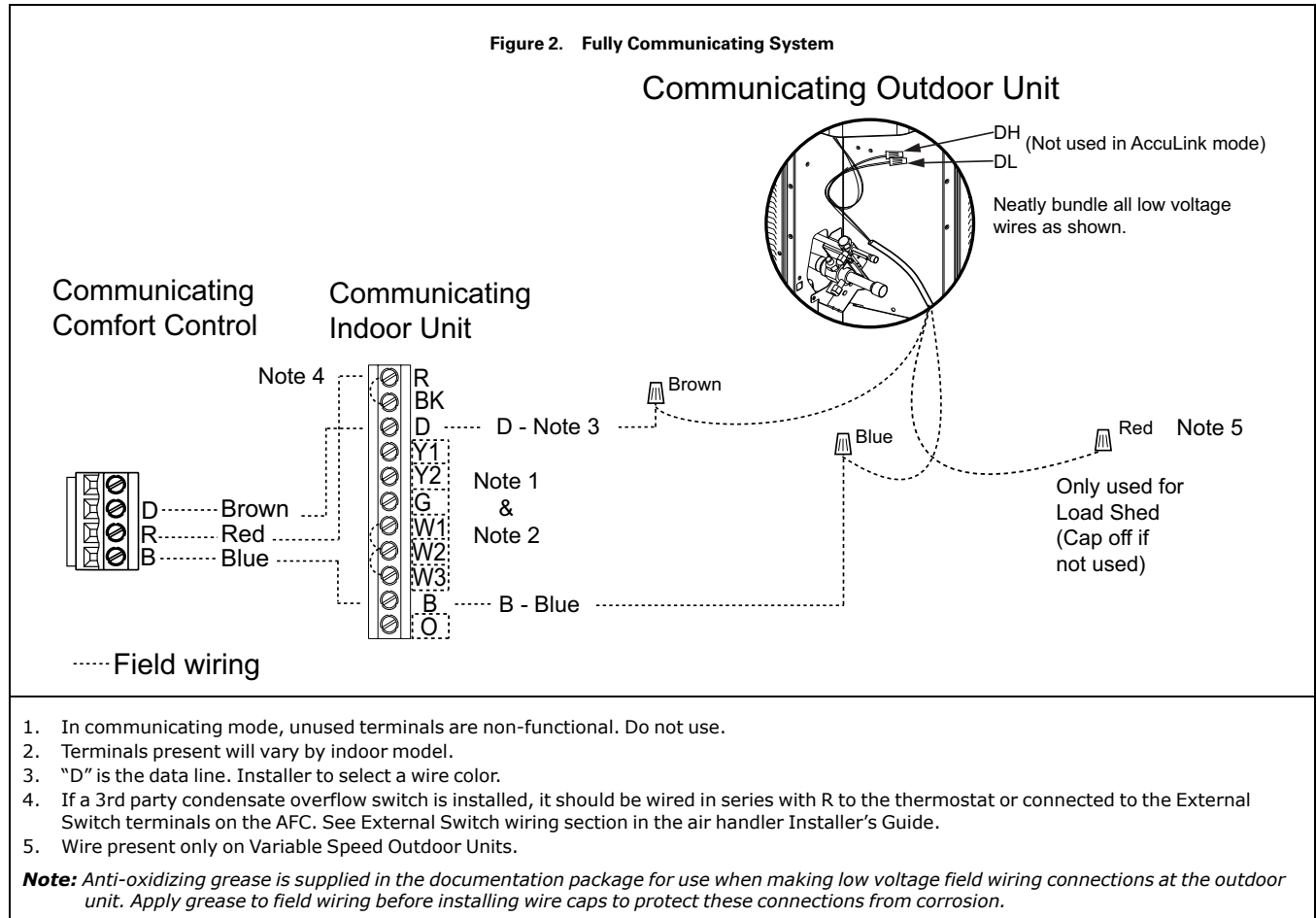

## Electrical – Low Voltage Communicating

**Table 22. American Standard Link Low Voltage Wire Connectors**

Link mode uses simple connectors for low voltage connections. These connections are color coded which makes the installation easier and quicker.

American Standard Link Wire Colors	
R	Red
DH	White
DL	Green
B	Blue

Do the following to make the connections from the actual thermostat wire to the connector.

**Note:** These connectors are necessary for the Outdoor unit, Indoor unit and Distribution board.

- Strip the Red, White, Green and Blue thermostat wires back 1/4".
- Insert the wires into the connector in the correctly colored locations.
- When you feel it release, allow each wire to slide in further.**
- Pull back on the wires individually and slightly and check if the wires are seated properly. If each wire does not pull out for all four wires, the connection is complete.
- Connectors are ONE TIME USE. If a 18 ga. Thermostat wire gets broken off inside of the connector, the connector will need replaced.
- Wire colors are for illustration purposes only. If using a different color, ensure it lands at the correct terminal throughout all of the communicating control wiring.

Connect the CAN connector into the male coupling on the low voltage harness at the Outdoor unit.

This air handler has two dedicated CAN Connector headers on the Air Handler Control (AHC) board. In American Standard Link communicating mode, both of them are in the communicating loop. It does not matter which one goes to the thermostat, System Controller, distribution board, outdoor unit or any other Link accessory.

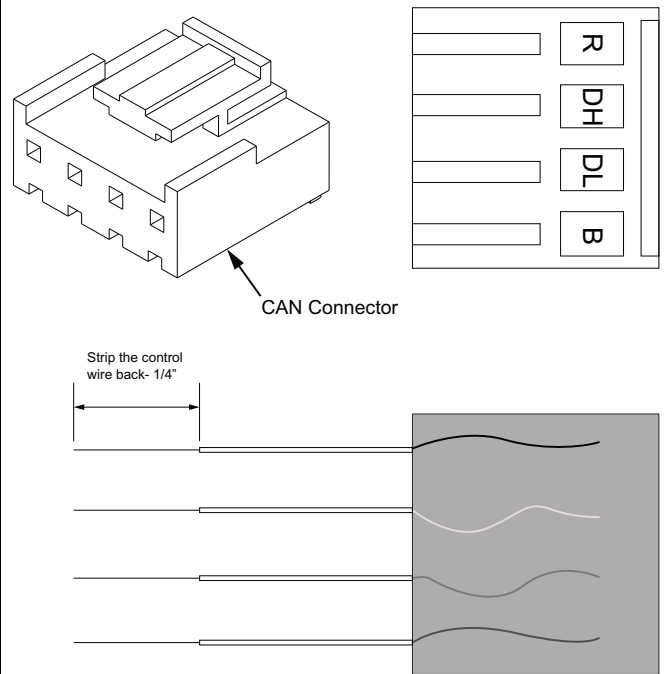

**Note:** For use with 18 ga. solid core thermostat wire.

**Note:** This connector should be removed when using this unit in AccuLink mode.

# Electrical – High Voltage

**Table 23. High Voltage Power Supply**

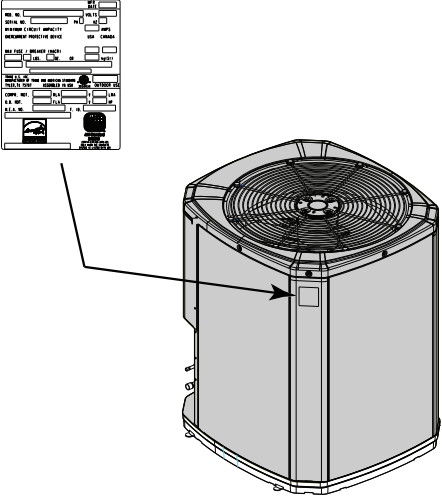
<div style="background-color: black; color: white; padding: 5px; text-align: center;"><b>⚠ WARNING</b></div> <p><b>LIVE ELECTRICAL COMPONENTS!</b> Failure to follow this Warning could result in property damage, severe personal injury, or death. Follow all electrical safety precautions when exposed to live electrical components. It may be necessary to work with live electrical components during installation, testing, servicing, and troubleshooting of this product.</p> <p>The high voltage power supply must agree with the equipment nameplate.</p> <p>Power wiring must comply with national, state, and local codes.</p> <p>Follow instructions on unit wiring diagram located on the inside of the control box cover and in the Service Facts document included with the unit.</p>	 <p>The diagram shows a high voltage power supply unit with a nameplate on the top left and a fan on the top right. An arrow points from the nameplate to the unit.</p>
---	---

**Table 24. High Voltage Disconnect Switch**

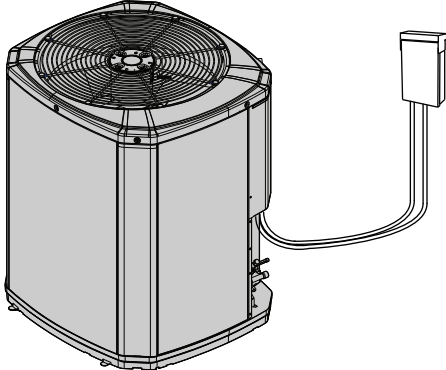
<div style="background-color: black; color: white; padding: 5px; text-align: center;"><b>⚠ WARNING</b></div> <p><b>HIGH LEAKAGE CURRENT!</b> Failure to follow this Warning could result in property damage, severe personal injury, or death. Earth connection essential before connecting electrical supply.</p> <p>Install a separate disconnect switch at the outdoor unit.</p> <p>For high voltage connections, flexible electrical conduit is recommended whenever vibration transmission may create a noise problem within the structure.</p>	 <p>The diagram shows a high voltage disconnect switch connected to an outdoor unit. The switch is a rectangular box with a handle, and it is connected to the unit by a cable.</p>
--	---

**Table 25. High Voltage Disconnect Switch**

**Do NOT connect the Variable Speed Outdoor units line voltage to a GFCI protected circuit.**

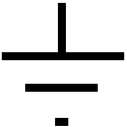
<p>Ground the outdoor unit per national, state, and local code requirements.</p>	 <p>The diagram shows a standard electrical grounding symbol, consisting of a vertical line connected to three horizontal lines of decreasing width, with a small square at the bottom.</p>
--	--

# Integrated Variable Speed Control Board LED Indicators

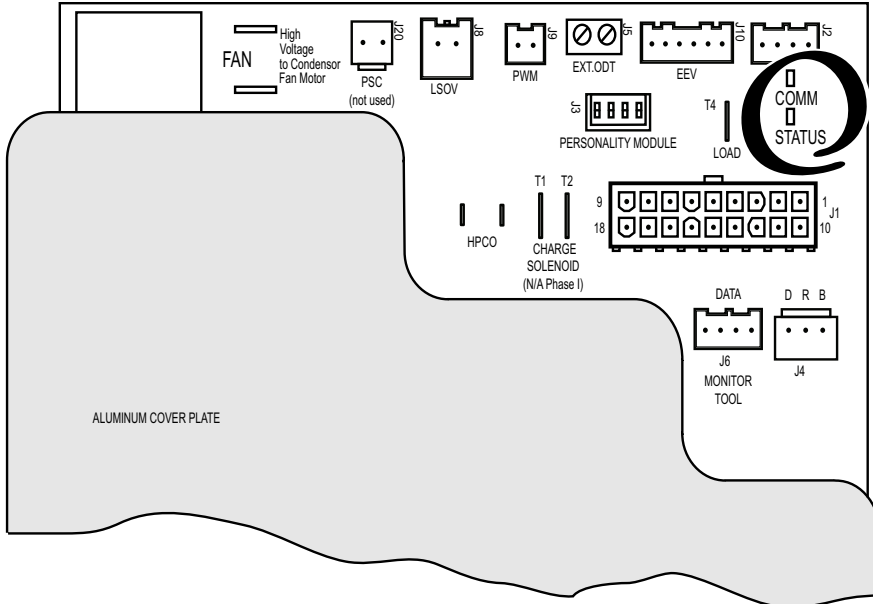

The Status (Green) and COMM (Amber) LEDs are located in the upper right region of the Control Board.

Fault messages are displayed on the CANda

**Table 26. LED'S in AccuLink mode**



LED	RATE	DESCRIPTION	INDICATION
STATUS (GREEN)	SLOW	1 TIME PER SECOND	STANDBY/IDLE
	MEDIUM	2 TIMES PER SECOND	CALL FOR CAPACITY
	FAST	5 TIMES PER SECOND	POWER UP DELAY
	SOLID ON		TEST MODE
	INTERMITTENT	1 FLASH EVERY 4 SECONDS	HARD LOCKOUT

**Note:** The STATUS Light is not illuminated in American Standard Link mode.

**Table 27. LED'S in AccuLink and American Standard Link modes**

LED	RATE	DESCRIPTION	INDICATION
COMM (AMBER)	SLOW	1 TIME PER DEVICE	DEVICE COUNT
	FAST	5 TIME PER SECOND	LOSS OF COMMUNICATION

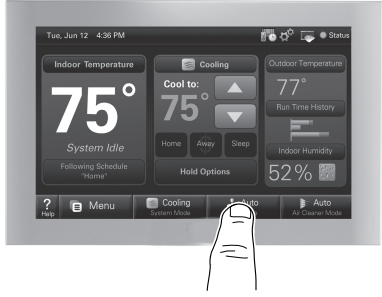
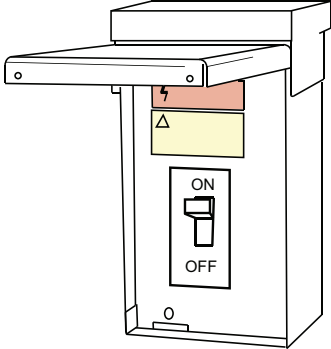
# Start Up

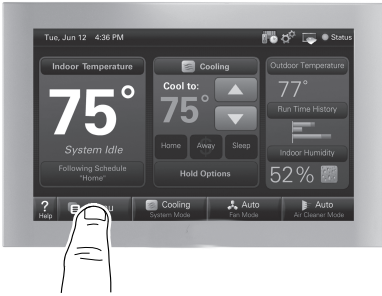
<p>1. Ensure you have completed the following sections. "Refrigerant Line Brazing," p. 12 through "Electrical — High Voltage," p. 19</p>	
<p>2. Set System Thermostat to OFF.</p>	
<p>3. Turn on disconnect(s) to apply power to the indoor and outdoor units.</p>	
<p>4. Wait 3 hours before starting the unit if the outdoor ambient temperature is below 85° F.</p>	
<p>5. Run the system using the "Charging Mode-Cooling" test mode found in the 850/950/1050 or UX360 Smart Thermostat controls. American Standard Link systems can also use the Diagnostic Mobile App to enter Test Modes. This is the only approved method for setting the system charge level by subcooling.</p> <p>Follow the on-screen prompts.</p> <p><b>Important:</b> ENSURE INDOOR BLOWER IS CONFIGURED FOR 400 CFM/TON IN ACCULINK MODE ONLY.</p>	

# System Charge Adjustment

**Table 28. Temperature Measurements**

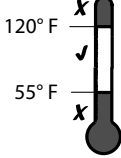
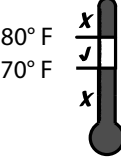
<p>Check the outdoor temperatures.</p> <p>Subcooling using <b>“Charging Mode-Cooling”</b> is the only recommended method of charging between 55 ° F and 120° F ambient outdoor temperature.</p>	
<p>For best results the indoor temperature should be kept between 70° F to 80° F.</p>	

**Table 29. Subcooling Charging Corrections**

<p>Determine the final subcooling value using total Line Length and Lift measured in “Required Refrigerant Line Length” and the “Subcooling Charging Corrections Charts.”</p>	<p><b>Subcooling Charging Correction Worksheet</b></p> <p>Total Line Length (ft) _____</p> <p>Total Vertical Charge (lift) _____ <i>(Values from — Required Refrigerant Line Length)</i></p> <p>Design Subcooling Value _____ <i>(from nameplate or Service Facts)</i></p> <p><b>Final Subcooling Value</b> _____</p>
---	---

**Note:** The only mode approved for setting or validating system charge is using Charging Mode-Cooling. Charging Mode-Cooling is a variable speed test mode found in the 850/950/1050 and UX360 comfort control Technician Menu’s. Test modes can also be accessed using the Diagnostic Mobile App on American Standard Link systems. Outdoor Temperature must be between 55°F and 120°F with Indoor Temperature kept between 70°F and 80°F.

**Important:** VARIABLE SPEED OUTDOOR UNITS REQUIRE THE INDOOR UNIT BE CONFIGURED FOR 400 CFM/TON IN ACCULINK MODE.

# Subcool Charging Correction Charts

**Important:** VARIABLE SPEED OUTDOOR UNITS REQUIRE THE INDOOR UNIT BE CONFIGURED FOR 400 CFM/TON IN ACCULINK MODE ONLY.

**Note:** System will auto configure airflow in American Standard Link mode.

**Figure 3. Subcool Charging Corrections — 2.0 Ton**

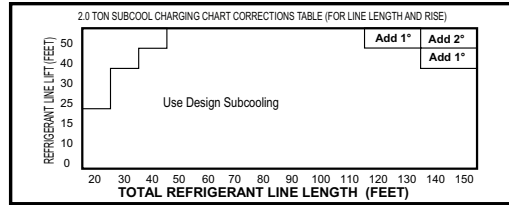

**Figure 4. Subcool Charging Corrections — 3.0 Ton**

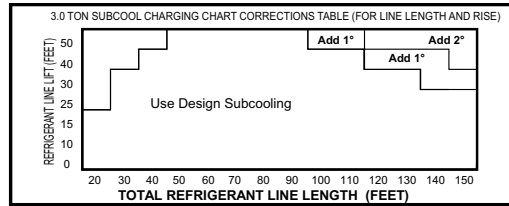

**Figure 5. Subcool Charging Corrections — 4.0 Ton**

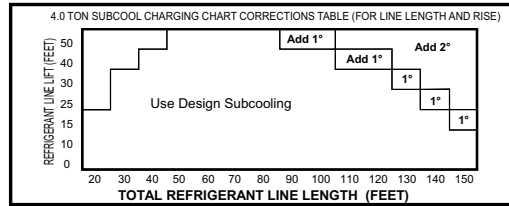

**Figure 6. Subcool Charging Corrections — 5.0 Ton**

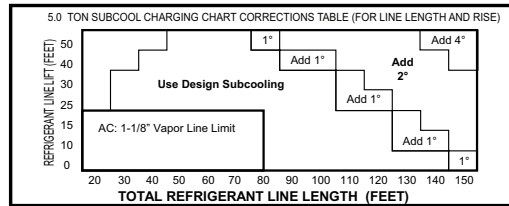

NOTE: 150 ft. length is approved ONLY with 7/8" vapor lines.

**Subcool Charging Correction Charts**

**Refrigerant Charging Chart**

<b>R-410A REFRIGERANT CHARGING CHART</b>							
LIQUID TEMP (°F)	DESIGN SUBCOOLING (°F)						
	8	9	10	11	12	13	14
	LIQUID GAGE PRESSURE (PSI)						
55	179	182	185	188	191	195	198
60	195	198	201	204	208	211	215
65	211	215	218	222	225	229	232
70	229	232	236	240	243	247	251
75	247	251	255	259	263	267	271
80	267	271	275	279	283	287	291
85	287	291	296	300	304	309	313
90	309	313	318	322	327	331	336
95	331	336	341	346	351	355	360
100	355	360	365	370	376	381	386
105	381	386	391	396	402	407	413
110	407	413	418	424	429	435	441
115	435	441	446	452	458	464	470
120	464	470	476	482	488	495	501
125	495	501	507	514	520	527	533



# Charging the Unit

**Important:** ENSURE INDOOR BLOWER IS CONFIGURED FOR 400 CFM/TON IN ACCULINK MODE.

**Table 30. Proper Gage Pressure**

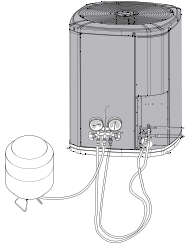
<p>Using the Standard R-410A Subcool Charging Chart, adjust refrigerant level to attain proper gage pressure. Add refrigerant if the Liquid Gage Pressure is lower than the chart value.</p> <ol style="list-style-type: none"> <li>1. Connect gauges to refrigerant bottle and unit as illustrated.</li> <li>2. Purge all hoses.</li> <li>3. Open bottle.</li> <li>4. Stop adding refrigerant when liquid line temperature and Liquid Gage Pressure match the charging chart.</li> </ol> <p><b>Note:</b> Recover refrigerant if the Liquid Gage Pressure is higher than the chart value.</p>	
---	---

**Table 31. Stabilize the system**

<ol style="list-style-type: none"> <li>5. Wait 20 minutes for the system condition to stabilize between adjustments.</li> </ol> <p><b>Note:</b> When the Liquid Line Temperature and Gage Pressure approximately match the chart, the system is properly charged.</p> <ol style="list-style-type: none"> <li>6. Remove gauges.</li> <li>7. Replace service port caps to prevent leaks. Tighten finger tight plus an additional 1/6 turn.</li> </ol>	
---	---

**Table 32. Verify Performance**

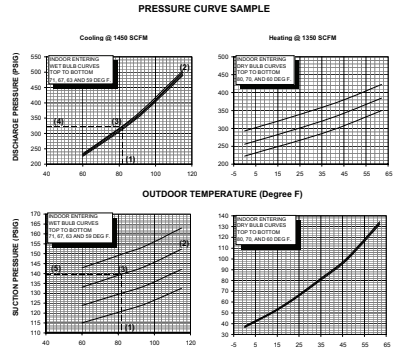
<ol style="list-style-type: none"> <li>8. Refer to System Pressure Curves in the Service Facts document to verify typical performance.</li> </ol>	
---	--

**Table 33. System Information**

<ol style="list-style-type: none"> <li>9. Record system pressures and temperatures after charging is complete.</li> </ol> <p>Outdoor model number = _____</p> <p>Measured Outdoor Ambient = _____ °F</p> <p>Measured Indoor Ambient = _____ °F</p> <p>Measured Liquid Line Temp = _____ °F</p> <p>Measured Suction Line Temp = _____ °F</p>	<p>Indoor Wet Bulb = _____ °F</p> <p>Liquid Gage Pressure = _____ PSIG</p> <p>Suction Gage Pressure = _____ PSIG</p>
---	--

# Subcooling Charging Below 55° F Outdoor Temp. (In Heating Only)

**Table 34. Subcooling Charging Below 55° F Outdoor Temp. (In Heating Only)**

The Subcooling Charging method in cooling is **not** recommended below 55° F outdoor temperature.

The only recommended method of charging at outdoor temperatures below 55° F is weighing in the charge in **heating mode** and referencing the refrigerant pressure curves for typical performance.

**STEP 1 - Determine additional charge.**

**Note:** The nameplate charge value represents the amount of refrigerant shipped in the outdoor unit and is compatible with 10 feet of AHRI rated refrigerant lines and the smallest AHRI rated coil.

Weigh-In Method can be used for the initial installation, or anytime a system charge is being replaced. Weigh-In Method can also be used when power is not available to the equipment site or operating conditions (indoor/outdoor temperatures) are not in range to verify with the subcooling charging method.

Using the method below, find the charge associated with the additional length of tubing above 10 ft. and record it below.

**Calculating Charge Using the Weigh-In Method**

1. Measure in feet the distance between the outdoor unit and the indoor unit. (Include the entire length of the line from the service valve to the IDU.) Subtract 10 ft from this entire length and record on line 1.
2. Enter the charge multiplier (0.6 oz/ft). Each linear foot of interconnecting tubing requires the addition of 0.6 oz of refrigerant.
3. Multiply the total length of refrigerant tubing (Line 1) times the value on Step 2. Record the result on Line 3 of the Worksheet.
4. This is the amount of refrigerant to weigh-in prior to opening the service valves.

1. Total Line length (ft) - 10 ft \_\_\_\_\_
2. Charge multiplier x \_\_\_\_\_ 0.6 oz \_\_\_\_\_
3. Step 1 x Step 2 = \_\_\_\_\_
4. Refrigerant (oz) = \_\_\_\_\_

**STEP 2 - Stabilize the system by operating for a minimum of 20 minutes.**

At startup, or whenever charge is removed or added, the system must be operated for a minimum of 20 minutes to stabilize before accurate measurements can be made.



**STEP 3 - Check the liquid line temperature and liquid gage pressure to obtain a minimum of 10° subcooling in heating mode.**

Measured Liquid Line Temp = \_\_\_\_\_ ° F

Liquid Gage Pressure = \_\_\_\_\_ PSIG

**STEP 4 - Add charge if a minimum of 10° subcooling is not obtained with the nameplate charge plus additional charge previously added.**

**STEP 5 - Return to site for adjustment.**

**Important:** Return in the spring or summer to accurately charge the system in the cooling mode with outdoor ambient **above 55° F**.

# Communicating Display Assembly (CANda)

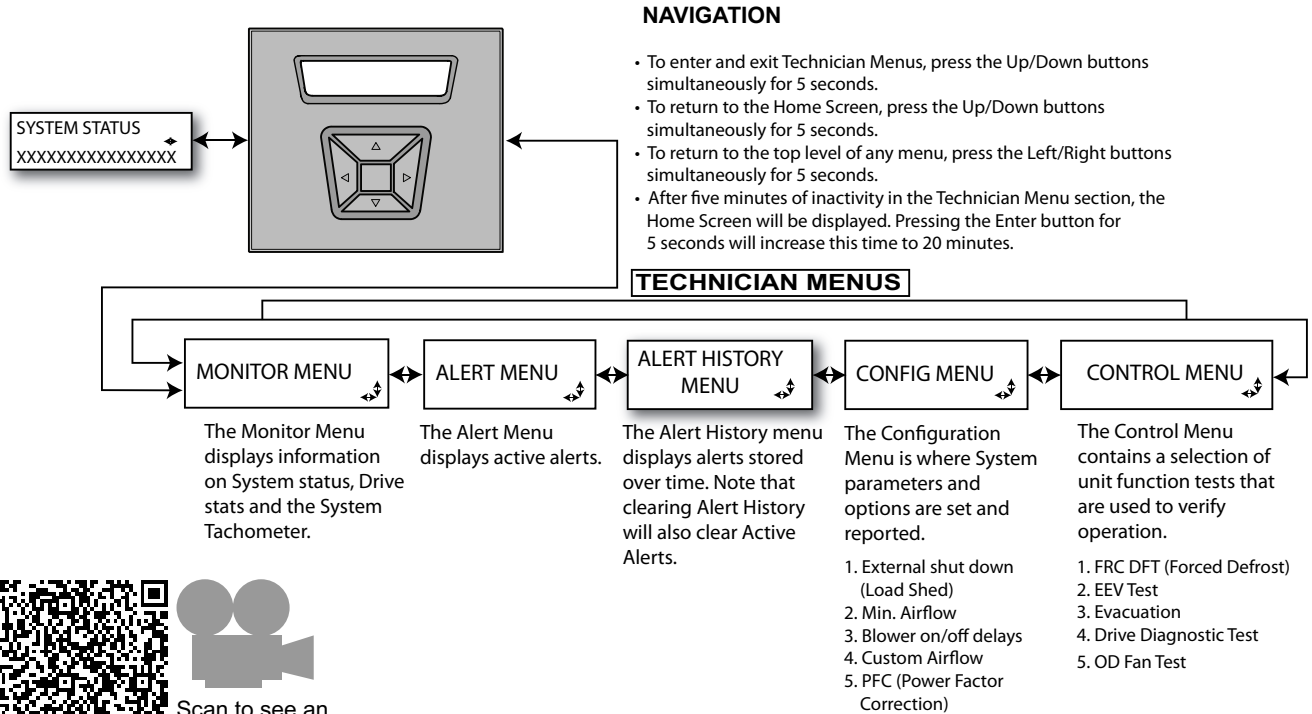

Scan to see an overview video about the CANda

**Note:** CONFIG MENU is only available in AccuLink mode.

**Note:** See the Service Facts found in the control box of the outdoor unit for more information.

# Defrost Control (Heat Pump only)

## Demand Defrost

The demand defrost control measures heat pump outdoor ambient temperature with a sensor located outside the outdoor coil. A second sensor located on the outdoor coil is used to measure the coil temperature. The difference between the ambient and the colder coil temperature is the difference or delta-T measurement. This delta-T measurement is representative of the operating state and relative capacity of the heat pump system. By measuring the change in delta-T, we can determine the need for defrost. The coil sensor also serves to sense outdoor coil temperature for termination of the defrost cycle.

## Fault Identification

A fault condition is indicated by the CANda connected to the control board inside the heat pump control box.

## Defrost Enabled

Demand Defrost is enabled with the following inputs to the Integrated Variable Speed Control (IVSC):

- Outdoor ambient temperature sensor (ODS-B) reporting an outdoor temperature at or below 52° F.
- Coil temperature sensor (CBS) reporting a coil temperature at or below 35° F.
- Heat/Cool Demand (HCD) from the communicating comfort control for at least two minutes or more.

## Defrost Initiation

The calculated temperature difference between the outdoor temperature sensor and the coil temperature sensor is called Delta T. Defrost can occur once the current Delta T exceeds the Delta T initiate value. This adaptive logic assures a complete defrost for a range of outdoor temperatures.

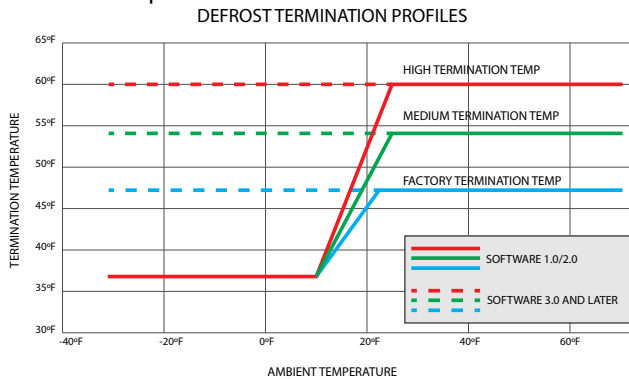

**Note:** A forced Defrost test can be entered through the 850/950/1050 or UX360 thermostats, the outdoor unit CANda or the American Standard Link Diagnostic Mobile App.

## CANda Navigation to Forced Defrost

Figure 7. CANda Mini Menu

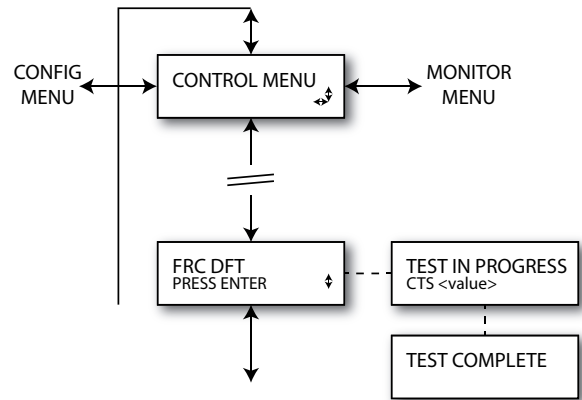

**Note:** CONFIG MENU only available in AccuLink mode

## NOTES: Forced Defrost

1. System must be running with demand from the thermostat.
  2. FRC DFT TEST can be initiated in heat mode only. DFC TEST can be entered from the CANda or Thermostat on AccuLink systems or from the CANda, UX360 User Interface or Diagnostic Mobile App in American Standard Link systems. Indoor AUX heat will energize when FRC DFT TEST is selected from the Outdoor CANda.
  3. Press ENTER to begin forced defrost.
  4. Execute Forced Defrost following Forced Defrost (Defrost terminates on Coil Temperature or maximum time override of 15 minutes).
  5. When test begins, TEST IN PROGRESS displays on line 1 and Coil Temperature value on line 2.
- Note:** Home Screen, under System Status will display DEFROST.
6. When test is complete, TEST COMPLETE displays for 10 seconds.
  7. If there is a defrost fault condition, test terminates and sends alert to the alert menu.
  8. For more information, refer to the Alert Code Tables in Service Facts and Technical Service Manual (Pub. No. 34-4301-01 or newer) documents.

**Note:** Screens will update as the test proceeds.

**Note:** Entering Forced Defrost from 850/950 or 1050 will not energize the indoor heat in AccuLink mode. Indoor heat will energize if entered from outdoor CANda.

**Note:** Can enter Forced Defrost from UX360, CANda or the Diagnostic Mobile App in American Standard Link mode.

## Checkout Procedures

The final phase of the installation is the system Checkout Procedures. The following list represents the most common items covered in a Checkout Procedure. Confirm all requirements in this document have been met.

<ul style="list-style-type: none"><li><input type="checkbox"/> All wiring connections are tight and properly secured.</li><li><input type="checkbox"/> Voltage and running current are within limits.</li><li><input type="checkbox"/> All refrigerant lines (internal and external to equipment) are isolated, secure, and not in direct contact with each other or structure.</li><li><input type="checkbox"/> All braze connections have been checked for leaks. A vacuum of 350 microns provides confirmation that the refrigeration system is leak free and dry.</li><li><input type="checkbox"/> Final unit inspection to confirm factory tubing has not shifted during shipment. Adjust tubing if necessary so tubes do not rub against each other or any component when unit runs.</li><li><input type="checkbox"/> Ductwork is sealed and insulated.</li><li><input type="checkbox"/> All drain lines are clear with joints properly sealed. Pour water into drain pan to confirm proper drainage. Provide enough water to ensure drain trap is primed.</li></ul>	<ul style="list-style-type: none"><li><input type="checkbox"/> Supply registers and return grilles are open, unobstructed, and air filter is installed.</li><li><input type="checkbox"/> Indoor blower and outdoor fan are operating smoothly and without obstruction.</li><li><input type="checkbox"/> Indoor blower motor set on correct speed setting to deliver required CFM. "Blower and fan set screws are tight."</li><li><input type="checkbox"/> Cover panels are in place and properly tightened.</li><li><input type="checkbox"/> For gas heating systems, manifold pressure has been checked and all gas line connections are tight and leak free.</li><li><input type="checkbox"/> For gas heating systems, flue gas is properly vented.</li><li><input type="checkbox"/> System functions safely and properly in all modes.</li><li><input type="checkbox"/> Owner has been instructed on use of system and given manual.</li></ul>
--	---





*American Standard*<sup>®</sup>  
HEATING & AIR CONDITIONING

About American Standard Heating and Air Conditioning  
American Standard has been creating comfortable and affordable living environments for more than a century. For more information, please visit [www.americanstandardair.com](http://www.americanstandardair.com).



The AHRI Certified mark indicates company participation in the AHRI Certification program. For verification of individual certified products, go to [ahridirectory.org](http://ahridirectory.org).

The manufacturer has a policy of continuous data improvement and it reserves the right to change design and specifications without notice. We are committed to using environmentally conscious print practices.